



LD2-CAN Series DC Servo Drive

User Manual

Foreword

Thank you for purchasing Leadshine LD2-CAN series DC Servo drives. This manual will provide information on the LD2-CAN series servo products regarding product safety & specifications, installations & wiring, tuning & problem diagnostics.





Please contact us at tech@leadshine.com if you need further technical support.

Incorrect operation may cause unexpected accident, please read this manual carefully before using product.

- ✧ We reserve the right to modify equipment and documentation without prior notice.
- ✧ We won't undertake any responsibility with any customer's modification of product and the warranty of product will be canceled at the same time.

Safety Precautions

Please read the safety instructions carefully before using the products and pay attention to the safety signs.

	Might incur death or serious injury
	Might cause injury to operating personals or damage to equipment
	Might cause damage to equipment
	Hot surface. Do not touch
	Protective Earth

Safety instructions

Warning

- ✓ The design of the product is not to be used in mechanical system which may incur health hazard.
- ✓ Users should be aware of the product safety precautions during design and installations of the equipment to prevent any unwanted accident.

Upon receiving

Caution

- ✓ The use of damaged or faulty product(s) is prohibited.
- ✓ Please refer to item checklist. If the labels don't match, please do not install.

Transportation



Caution

- ✓ Please provide storage and transportation under protected conditions.
- ✓ Do not stack the products too high up to prevent toppling.
- ✓ The product should be packaged properly during transportation,
- ✓ Do not hold the product by the cable, motor shaft or encoder while transporting it.
- ✓ The product should be protected from external forces and shock.

Installation



Caution

Servo drive and Motor:

- ✓ Do not install around combustibles to prevent fire hazard.
- ✓ Avoid vibration and impact.
- ✓ Do not install products that are damaged or incomplete.

Servo drive:

- ✓ Please install in electrical cabinet with sufficient protection from outside elements.
- ✓ Reserve sufficient gap as per the installation guide.
- ✓ Make sure to have good heat sinking.
- ✓ Avoid dust, corrosive gas, conductive object or fluid and combustibles.

Servo Motor:

- ✓ Make sure installation is tight to prevent it from loosening.
- ✓ Prevent fluid from leaking into motor and encoder.
- ✓ Protect motor from impact to avoid damaging encoder.
- ✓ Motor shaft should not bear the load beyond the limits as specified.

Wiring



Warning

- ✓ Participate installation personals should have sufficient training in product installation safety.
- ✓ Please power off and wait for 10 minutes to make sure a full discharge of electricity.
- ✓ Servo drive and motor must be connected to ground.
- ✓ Connect the cables only after servo drive motor installed correctly
- ✓ Make sure the wires are properly managed and insulation layer is not torn to prevent electrocution.



Caution

- ✓ Wiring must be correctly connected to prevent damage to product(s)
- ✓ Servo motor U, V, W terminal should be connected correctly and NOT connected directly to an AC power supply.
- ✓ Capacitor, inductor or filter shouldn't be installed between servo motor and servo drive.
- ✓ Connecting wires or any non-heat resistant components should be put near to heat sink of the servo drive or motor.
- ✓ The flyback diode which is connected in parallel to output signal DC relay must not be connected in reverse.

Tuning and running**Caution**

- ✓ Make sure the wirings of servo drive and servo motor are installed and fixed properly before powering on.
- ✓ On the first time tuning of the product, it is recommended to run unloaded until all the parameter settings are confirmed to prevent any damage to the product or machine.

Usage**Caution**

- ✓ Please install an emergency stop button on machine to stop operation immediately if there is an accident.
- ✓ Please make sure machine is stopped before clearing an alarm.
- ✓ Servo drive must be matched with specified motor.
- ✓ Frequent restart of the servo system might incur damage to the product.
- ✓ Servo drive and motor will be hot to touch shortly after power off. Please be careful.
- ✓ Modification(s) to servo system is prohibited.

Error Handling**Warning**

- ✓ Please wait for 5 minutes after powering off for the electricity to be fully discharged before uninstalling the cables.
- ✓ Participate maintenance personals should have sufficient training in maintenance and operation of this product series.

**Caution**

- ✓ Please handle the error before clearing an alarm.
- ✓ Keep away from machine after a restart upon alarm. Mechanical axis might suddenly move. Such hazard should be prevented during the utilization of the product.

Model Selection**Caution**

- ✓ Rated torque of the servo motor should be higher than continuous designated torque when fully loaded.
- ✓ Load inertia ratio of the motor should be lower or equals to recommended value for specified models
- ✓ Servo drive must be matched with specified motor.

Warranty Information

Available for

Leadshine overseas warranty only covers Leadshine DC servo products that are obtained through **Leadshine certified sales channel outside of China.**

Warranty claim

- All Leadshine DC servo products (Servo drives and motors) overseas enjoy **18-month** warranty period.
- Due to unforeseen circumstances in different sales regions around the globe, we recommend users to seek technical support from directed sales channel as any warranty claim or repair services may be required.
- Please be informed that any maintenance/repair work that is outside of the warranty claim conditions might incur some charges and to be confirmed before product(s) is being sent in.
- The duration required for maintenance work to be done is to be confirmed after initial check-up but we reserve the right to prolong the repair duration if needed.
- Discontinued products within warranty period will be replaced with a product of similar specifications.

Steps to warranty claim

1. Visit Leadshine global site www.leadshine.com to look for local certified sales channel.
2. Contact designated sales channel to check if any fee might incur. May include repair fee, spare part cost or shipping cost.

Circumstances where warranty claim is not available

- Damage/Loss due to occurrence of natural or man-made disaster such as fire, flood or earthquake.
- Installation or wiring error
- If there is any modification done to the product
- Warranty label on products is torn or not existing
- Not a product bought from Leadshine certified global network of retailers/distributors.

Before warranty claim

- Please backup device parameters before any repair work/warranty claim. Leadshine and Leadshine certified retailers/distributors will not be held responsibilities for any data loss.
- If available, please send product back in original packaging or make sure it is well packaged to prevent any damage to the product during shipping.

Leadshine Technology Co.,Ltd. and its certified sales channel reserved the final right of the interpretation of the warranty information.

TABLE OF CONTENT

CHAPTER 1 INTRODUCTION	9
1.1 PRODUCT INTRODUCTION	9
1.2 MODEL NUMBER STRUCTURE	10
1.2.1 Servo Drive	10
1.2.2 Servo Motor	错误!未定义书签。
1.3 SERVO DRIVE TECHNICAL SPECIFICATION	11
1.4 SERVO DRIVE PORTS AND CONNECTORS	12
1.5 MOTOR PORTS AND CONNECTORS	13
CHAPTER 2 INSTALLATION & WIRING	14
2.1 SERVO DRIVE INSTALLATION	14
2.1.1 Servo drive installation environment	14
2.1.2 Servo drive dimension	14
2.2 SERVO MOTOR INSTALLATION	17
2.2.1 Installation conditions	17
2.2.2 Precautions during installation	17
2.3 LD2-CAN WIRING DIAGRAM	18
2.4 SERVO DRIVE PORTS	19
2.4.1 CN1 I/O Signal Port	21
2.4.2 CN3/CN4 Power supply & Regenerative Resistor Port	22
2.4.3 CN5 CANopen Communication Port	22
2.4.4 CN6 Safe Torque Off (STO) Port	23
2.4.5 CN7 RS232 Tuning Port	24
2.4.6 CN9 Logic Circuit Power Supply Port	25
2.4.7 ENC Encoder Feedback Port	25
2.4.8 ID spin dial RSC	26
2.4.9 Baud rate/Terminal resistor switch SW	26
2.5 CABLE SELECTION	27
2.5.1 Motor Power Cable	27
2.5.2 Motor Encoder Cable	28
2.5.3 Motor Brake Cable	29
2.5.4 Drive Communication Cable	29
2.5.5 Tuning Cable	29
2.6 REGENERATIVE RESISTOR SELECTION	30
CHAPTER 3 PARAMETER	34
3.1 PARAMETER LIST	34
3.1.1 Servo drive parameter	34
3.1.2 Motion parameter starting with object dictionary 6000	40
3.2 PARAMETER FUNCTION	42
3.2.1 【Class 0】 Basic Settings	42
3.2.2 【Class 1】 Gain Adjustments	46

3.2.3	【Class 2】 Vibration Suppression	53
3.2.4	【Class 3】 Velocity/ Torque Control	58
3.2.5	【Class 4】 I/O Interface Setting.....	60
3.2.6	【Class 5】 Extension settings	66
3.2.7	【Class 6】 Other settings.....	70
3.3	402 PARAMETERS FUNCTION	74
CHAPTER 4 CONTROL MODE		86
4.1	PROFILE POSITION MODE	86
4.1.1	Pulse.....	86
4.1.2	Motion settings.....	86
4.1.3	Monitoring settings.....	87
4.1.4	Applications example.....	87
4.2	PROFILE VELOCITY MODE.....	88
4.2.1	Motion Settings.....	88
4.2.2	Monitoring settings.....	88
4.3	PROFILE TORQUE MODE	89
4.3.1	Motion Settings.....	89
4.3.2	Monitoring settings.....	89
4.4	HOMING MODE.....	90
4.4.1	Motion Settings.....	90
4.4.2	Monitoring settings.....	90
4.4.3	Homing mode.....	91
4.5	EMERGENCY STOP	116
4.5.1	Motion Settings.....	116
4.5.2	Monitoring settings.....	116
CHAPTER 5 APPLICATIONS		117
5.1	TRIAL RUN	117
5.2	INERTIA RATIO MEASURING	118
5.3	NOTCH FILTER (VIBRATION SUPPRESSION)	120
5.4	AUTO GAIN ADJUSTMENT	122
5.5	3 RD GAIN SWITCHING	124
5.6	FRICTION COMPENSATION FUNCTION.....	126
5.7	REGENERATIVE RESISTOR SETTINGS	127
5.8	SAFETY FUNCTIONS	128
5.8.1	Max. motor rotational speed limitation.....	128
5.8.2	Max. duration for motor to stop after disabling.....	128
5.8.3	External brake deactivation output signal BRK-OFF	129
5.8.4	Servo stopping mode.....	130
5.8.5	Emergency stop function.....	131
5.9	MULTITURN ABSOLUTE ENCODER	132
5.9.1	Parameter settings.....	132
5.9.2	Read absolute position.....	133
5.9.3	Absolute Encoder Related Alarm.....	135

CHAPTER 6 CANOPEN COMMUNICATION	136
6.1 COMMUNICATION CONNECTION	136
6.2 CANOPEN COMMUNICATION PARAMETERS AND PORTS.....	136
6.3 CANOPEN COMMUNICATION PROTOCOL.....	138
6.4 PREDEFINED CONNECTIONS	138
6.5 OBJECT DICTIONARY	139
6.5.2 <i>Object dictionary structure</i>	140
6.5.3 <i>Object type</i>	140
6.5.4 <i>Access attribute</i>	140
6.6 NETWORK MANAGEMENT (NMT).....	141
6.6.1 <i>NMT module control</i>	141
6.6.2 <i>NMT node guarding</i>	141
6.6.3 <i>NMT Boot-up</i>	142
6.6.4 <i>NMT communication status machine</i>	142
6.7 PROCESS DATA OBJECT (PDO)	143
6.8 SERVICE DATA OBJECT.....	146
6.9 EMERGENCY OBJECT	147
CHAPTER 7 WARNING AND ALARM	148
7.1 SERVO DRIVE ALARM OVERVIEW	148
7.2 ALARM HANDLING.....	153
7.3 CANOPEN COMMUNICATION ALARM.....	165
7.4 ALARM CLEARING	175
7.4.1 <i>Servo Drive Alarm Clearing</i>	175
CONTACT US	176

Chapter 1 Introduction

1.1 Product Introduction

LD2-CAN Series DC Servo Drive is our latest generation DC servo drive that is based on CANopen DSP402 protocol. It can be easily matched to any controller that supports this protocol. Using the latest signal processing chip from Texas Instrument, the drive is compact with small volume and good reliability.

In comparison to conventional pulse controlled servo drives, our LD2-CAN provides advantages as listed below.

1. Lengthen communication range and lower electromagnetic interference

Due to the reliance of pulse command, pulse controlled servo drives could be easily disrupted by electromagnetic interferences. CANopen communication protocol provides fault detections limitations and error handling that makes communication more reliable over long distances.

2. Greater motion control

Trajectory generation can be done within the driver under non-cyclic synchronous mode. Controller only needs to deliver target position, velocity and acceleration commands to the driver. Drivers can then achieve greater control by applying feedforward to the commands.

3. Simplify complex wiring work

Using CANopen communication protocols, the connections between master device and slave stations can be realized using only RS232 cables.

4. Reduce cost by lowering the requirement for more ports

Multiple axes control can be realized without requirement for more ports or pulse module on the master device/controller. Only a network port is needed to chain the axis controller (drivers) together in series.

1.2 Model Number Structure

1.2.1 Servo Drive



No.	Description	
①	Series No.	LD2: DC Servo Drive Series
②	Communication protocol	RS: Pulse train + Modbus RTU CAN: CANopen + Analogue
③	Power Rating	7020: 24-70VDC, rated current 20A 7030: 24-70VDC, rated current 30A
④	Type	B: Holding brake output <i>Blank</i> : Without holding brake output

1.3 Servo Drive Technical Specification

LD2-CAN series	CAN7005B	CAN7010B	CAN7015B	CAN7020B	CAN7030B
Rated Current (Arms)	5	10	15	20	30
Peak Current (Arms)	21	42	45	80	90
Dimension(mm)	140*79.5*25.5		175*100.5*33		
LD2-CAN series	CAN7040B		CAN7060B		
Rated Current (Arms)	40		60		
Peak Current (Arms)	120		180		
Dimension(mm)	194*103*41				
Logic Power Supply	24VDC				
Safe Torque Off (STO)	STO SIL3				

Main power supply	24 ~ 70VDC
Direct Drive Holding Brake	Yes
Drive mode	SVPWM sinusoidal wave drive
Velocity regulation ratio	5000:1
Electronic gear ratio	1 ~ 32767/1 ~ 32767
Matching encoders	Hall signal UVW + ABZ or RS485 encoder (Tamagawa protocol)
Input	4 configurable NPN/PNP 24V Digital Inputs: DI3-DI6
	<ol style="list-style-type: none"> 1. Servo enabled (SRV-ON) 2. Positive limit switch (POT) 3. Negative limit switch (NOT) 4. Clear Alarm (A-CLR) 5. Gain switching (GAIN) 6. Deviation counter clearing (CL) 7. Command pulse prohibition(INH) 8. Crossover frequency input switching(DIV1) 9. Internal command velocity selection(INTSPD) 10. Zero speed clamp(ZEROSPD) 11. Velocity sign(VC-SIGN) 12. Torque sign(TC-SIGN) 13. Emergency Stop (E-STOP)
Output	1 holding brake output;2 configurable single-ended NPN/PNP 24V, 8mA digital outputs
	<ol style="list-style-type: none"> 1. Alarm (ALARM) 2. Servo ready (SRDY) 3. External brake off (BRK-OFF) 4. Positioning completed (INP1) 5. Reached velocity(AT-SPEED) 6. Zero speed position (ZSP) 7. Velocity coincidence (V-COIN) 8. Position command (P-CMD) 9. Velocity command (V-CMD)
Alarm	Current circuit error, DC bus overvoltage, DC bus undercurrent, overcurrent, overcurrent on IPM, motor overload, regenerative resistor overload, encoder disconnected, encoder initialization error, encoder data error, excessive position deviation, overspeed, I/O configuration error, EEPROM parameter saving CRC checksum error, positive/negative position limit valid, forced alarm input valid
Indicator light	Red & Green LED
Tuning Software	Motion Studio 2

Motion Studio 2	Configure parameters for current, position and velocity loop. Parameter uploading using .lsr parameter files. Drive and motor data monitoring using oscilloscope.	
Communication Port	RS-232 , 1 : 1 ; CAN , 0 : N (0≤N≤127) , CANopen	
Load-Inertia	Smaller than 20 times motor inertia	
Environmental requirements	Storage condition	Avoid direct sunlight. Keep away from heat generating devices, dust, oil, corrosive liquid/gas and places with strong vibration or high humidity. Prohibit combustible gas and conductive material waste.
	Temperature	-20°C ~ + 45°C (Please allow air circulation if >45°C)
	Storage temperature	- 20°C ~ + 65°C
	Humidity	40—90%RH (Condensation free)
	Installation	Vertical and level to ground

1.4 Servo Drive Ports and Connectors

LD2-CAN Series Servo Drive (7005B/7010B/7015B/7020B/7030B)

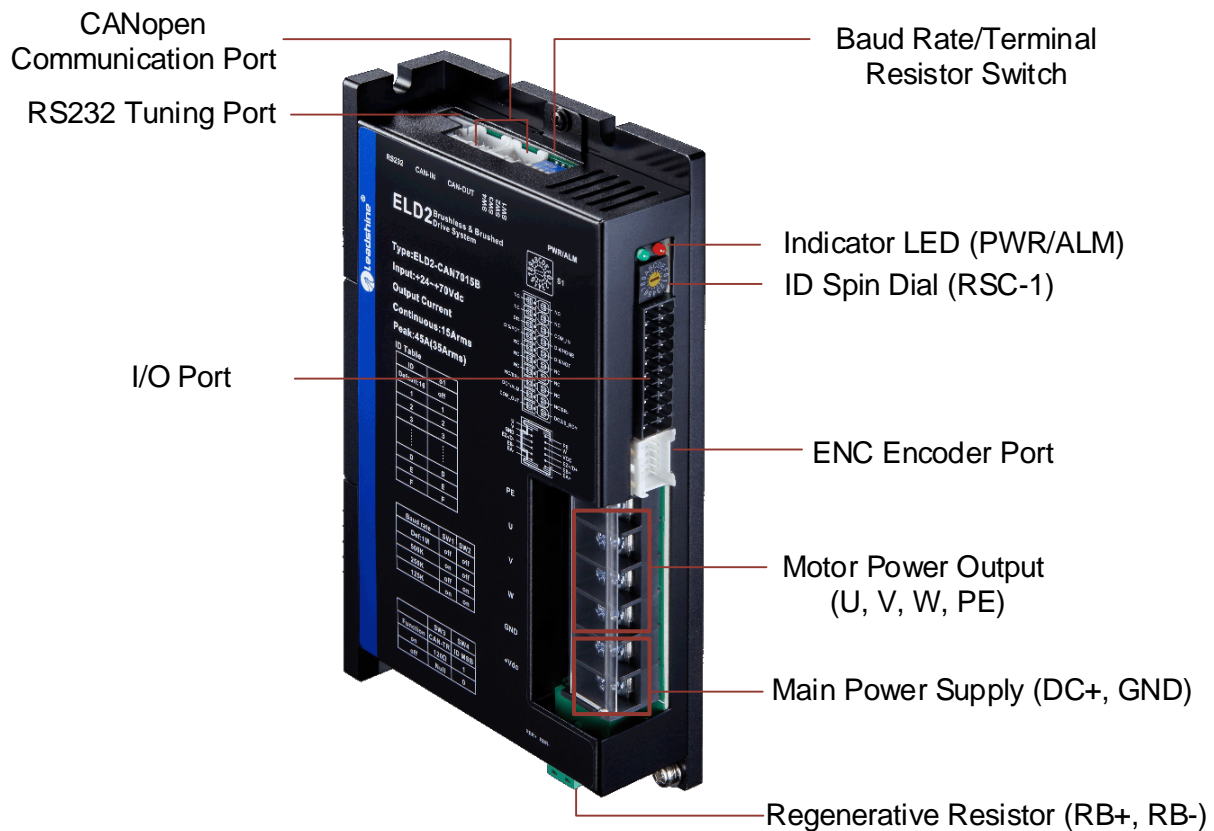

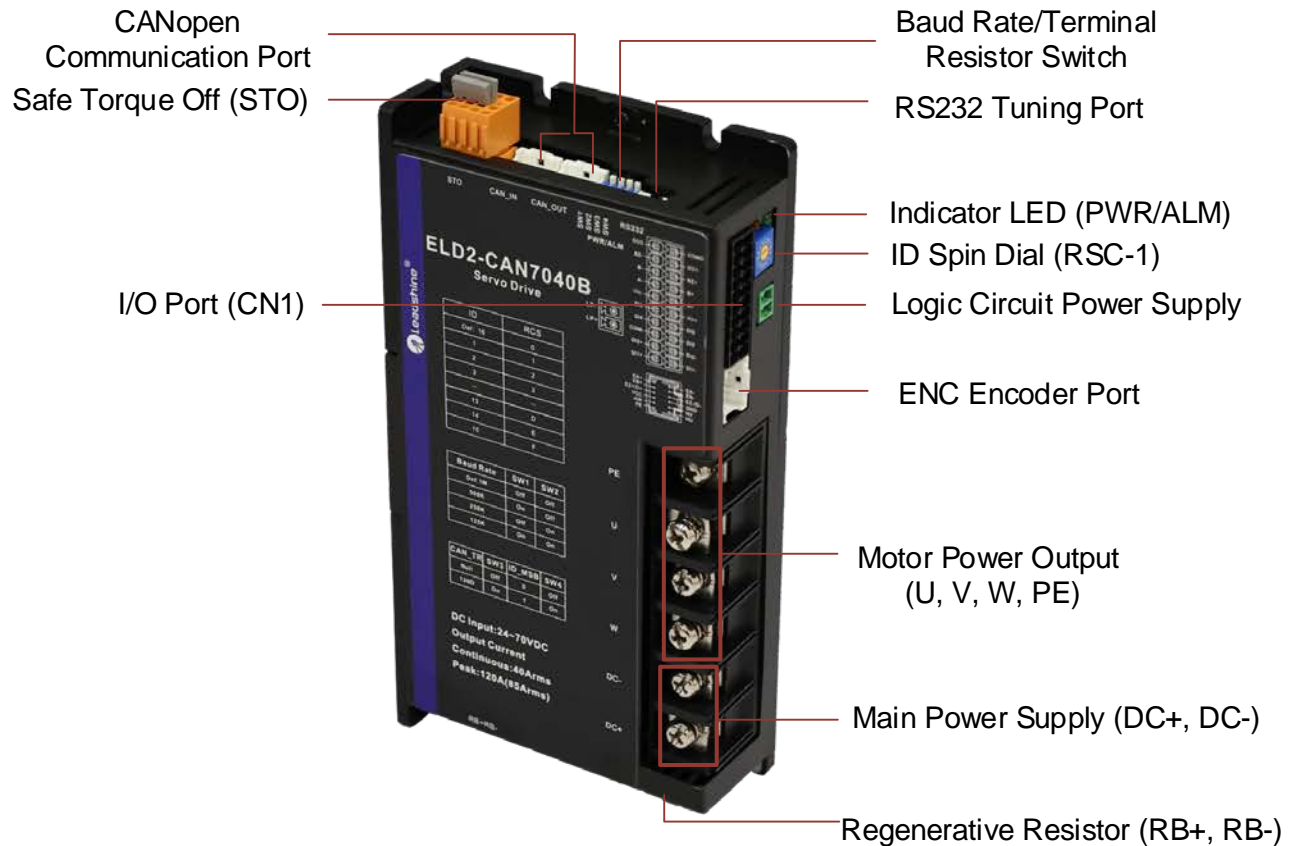
LD2-CAN Series Servo Drive (7040B/7060B)

1.5 Motor Ports and Connectors

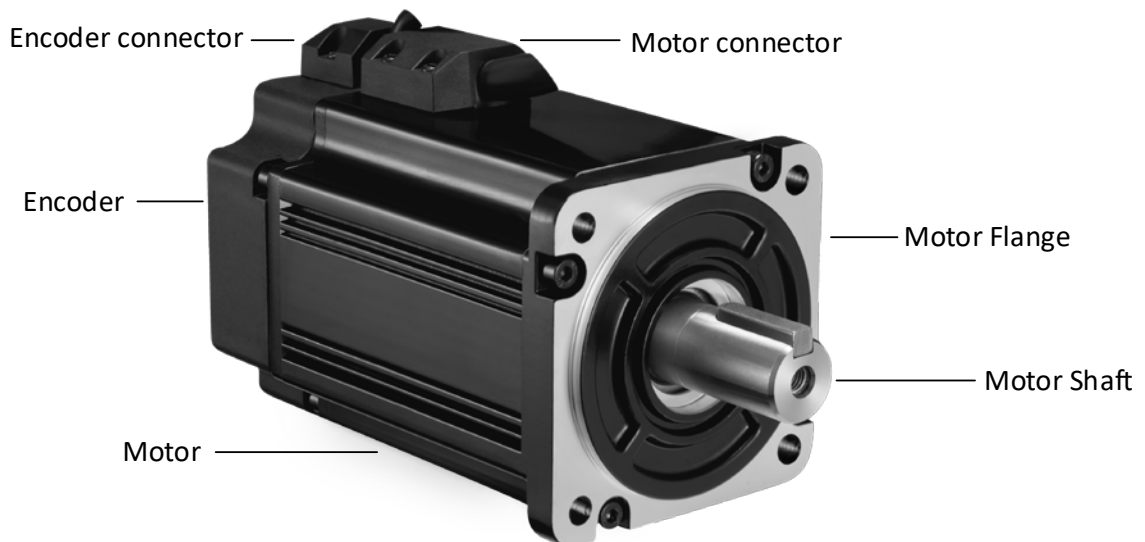
LVM Series DC Servo Motor

Chapter 2 Installation & Wiring

2.1 Servo Drive Installation

2.1.1 Servo drive installation environment

Temperature	Storage: -20~+65°C (Condensation free); Installation: -20~+45°C (Please allow air circulation if >45°C)
Humidity	Under 90%RH (Condensation free)
Altitude	Up to 1000m above sea level
Atmospheric pressure	86 ~ 106kPa
Vibration	Less than 0.5G (4.9m/s ²) 10-55Hz (non-continuous working)
Atmospheric	No corrosive gas, combustibles, dirt or dust.
IP ratings	IP20

2.1.2 Servo drive dimension

Dimension 1: LD2-CAN7005B/7010B

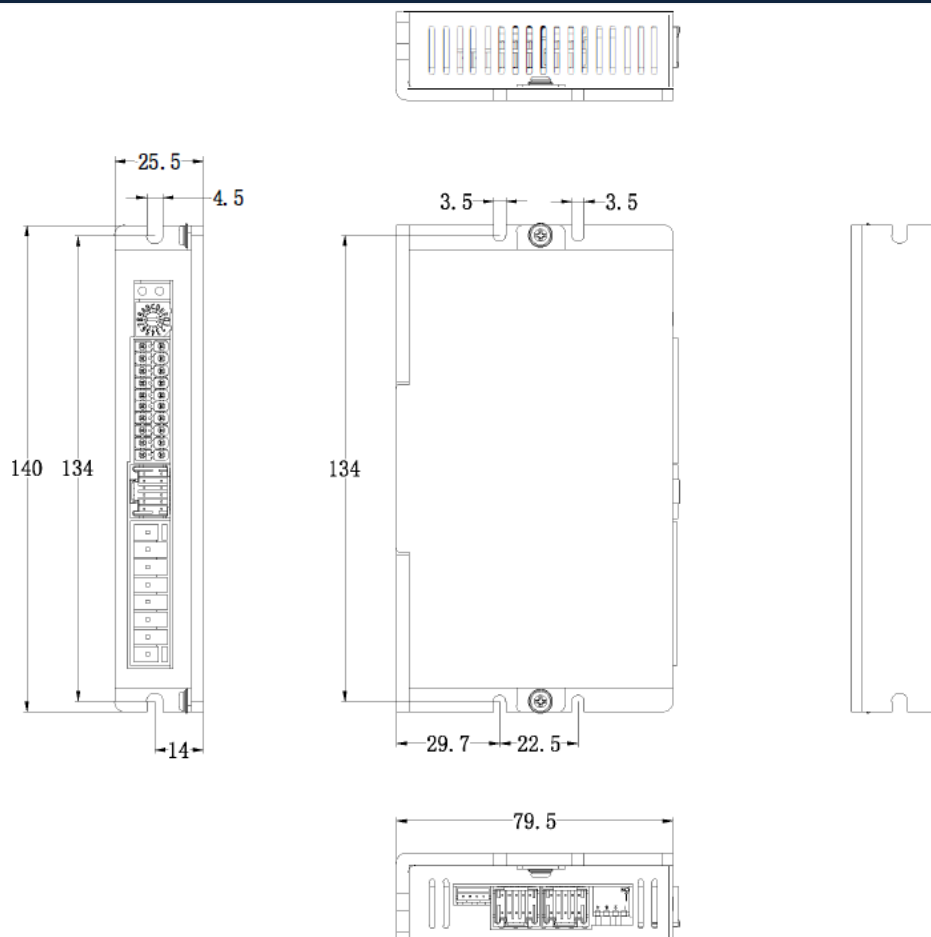

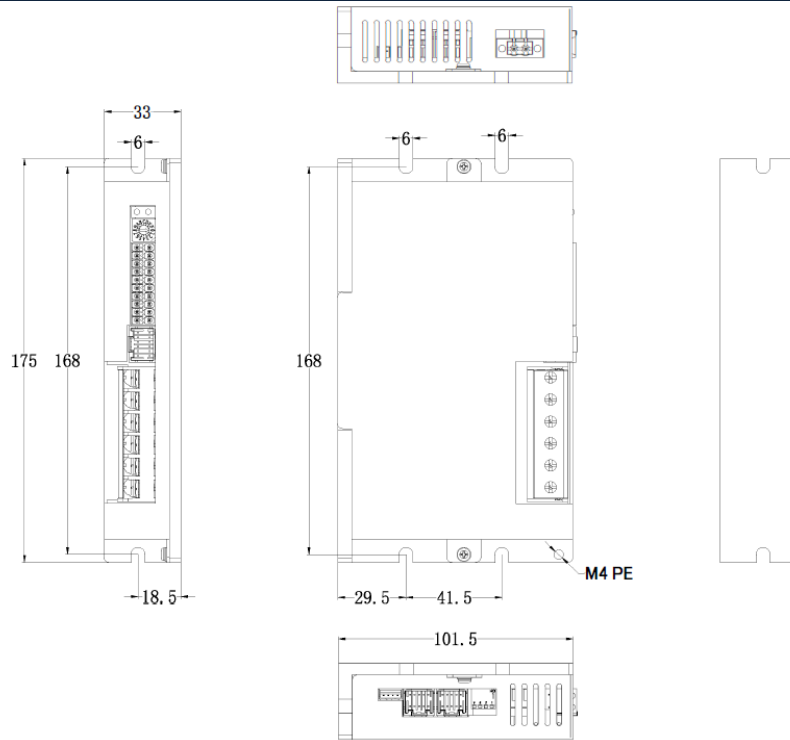
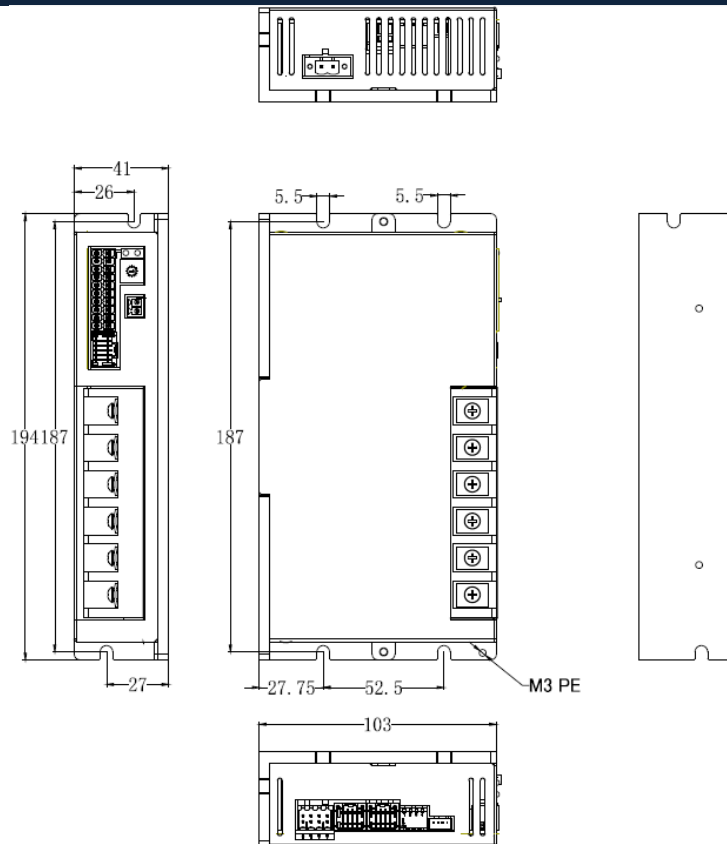
Dimension 2: LD2-CAN7015B/7020B/7030B

Dimension 3: LD2-CAN7040B/7060B

Space requirement for installation

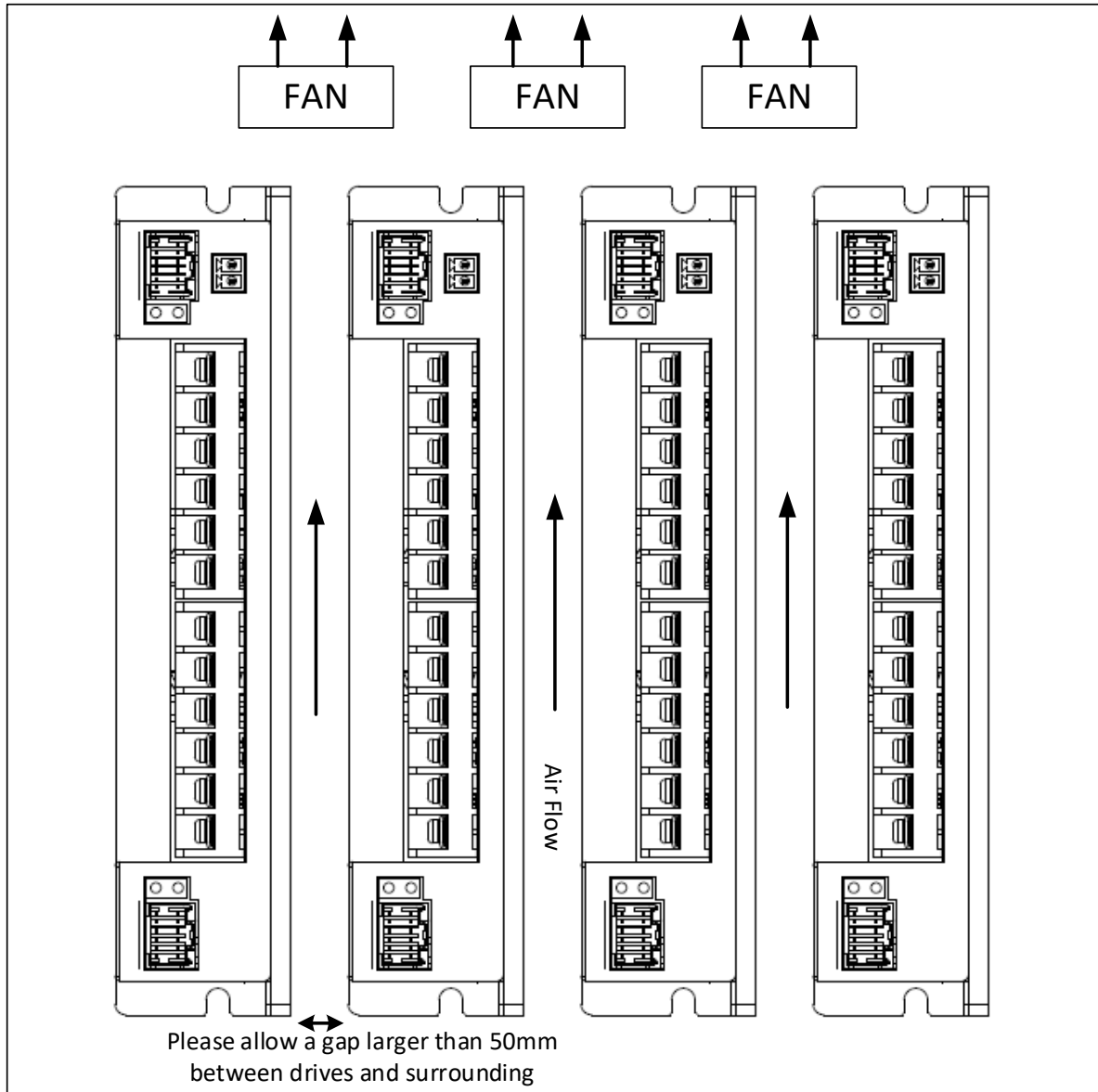
1. Please install the drive vertical to ground.
2. Please ensure optimal heat dissipation with enough room (>50mm) between each drives or to surrounding. It is recommended to install cooling fans for drives to achieve optimal performance.



Please refer to the diagram above for a visual guide on how to properly install the DC servo drives.

2.2 Servo Motor Installation

2.2.1 Installation conditions

Installation conditions may affect the lifespan of a motor

- Please keep away from corrosive fluid and combustibles.
- If dusty working environment is unavoidable, please use motors with oil seal.
- Please keep away from heat source.
- If motor is used in enclosed environment without heat dissipation, motor lifespan will be short.
- Please check and clean the installation spot before installation.

2.2.2 Precautions during installation

Installation method

Install horizontal to ground

Make sure power cable and encoder cable is facing downwards to make sure fluid doesn't leak into the ports.

Install vertical to ground

Please use a motor with oil seal when paired with a reducer to prevent reducer oil from leaking into the motor.

Oil- and waterproofing

- Do not submerge motor/cable under oil/water
- Please use a motor with oil seal when paired with a reducer to prevent reducer oil from leaking into the motor.
- If there is an unavoidable fluid leakage near the motor, please use motor with better IP ratings.
- Make sure power cable and encoder cable is facing downwards to make sure fluid doesn't leak into the ports.
- Avoid the usage of motor in water/oil leaking prone environment.

Cable under stress

- Do not the bend the cable especially at each ends of the connectors.
- Make sure to not let the cables be too tight and under tremendous stress especially thinner cables such as signal cables.

Connectors

- Please to remove any conductive foreign objects from the connectors before installation
- The connectors are made of resin. May not withstand impact.
- Please hold the driver during transportation, not the cables.
- Leave enough "bend" on the connector cables to ensure less stress upon installation.

Encoder & coupling

- During installation or removal of coupling, please do not hit the motor shaft with a hammer as it would cause damage to internal encoder.
- Please make sure to centralize the motor shaft and coupling, it might cause damage to motor or encoder due to vibration.
- Please make sure axial and radial load is within the limits specified as it might affect the lifespan of the motor or cause damage to it.

2.3 LD2-CAN Wiring Diagram

LD2-CAN Wiring Diagram

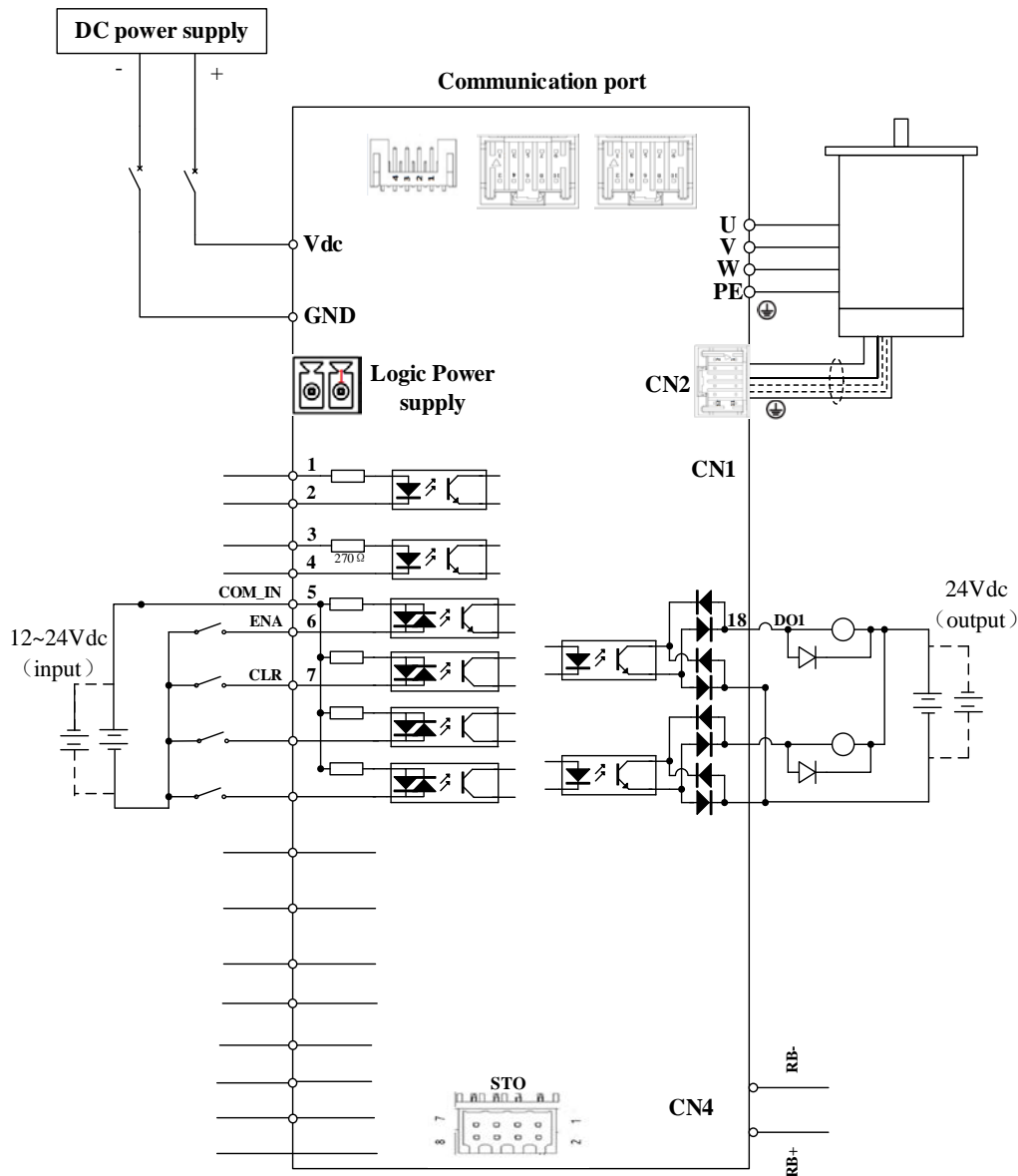

- Make sure data transferring cables are as short as possible. Keep CN1 cable under 3m and CN2 cable under 10m. Use shielded double winding cables to cut down on electromagnetic interference.
- If the load for DO is an inductive load such as a relay, please install freewheeling diodes on both ends of the load in parallel. Please keep in mind that if the diode is connected in reverse, it might cause damage to the drive.
- Use non-fuse breaker (NFB) to cut off power supply to the drive in case of emergency.

2.4 Servo Drive Ports

LD2-CAN 7005B/7010B/7015B/7020B/7030B

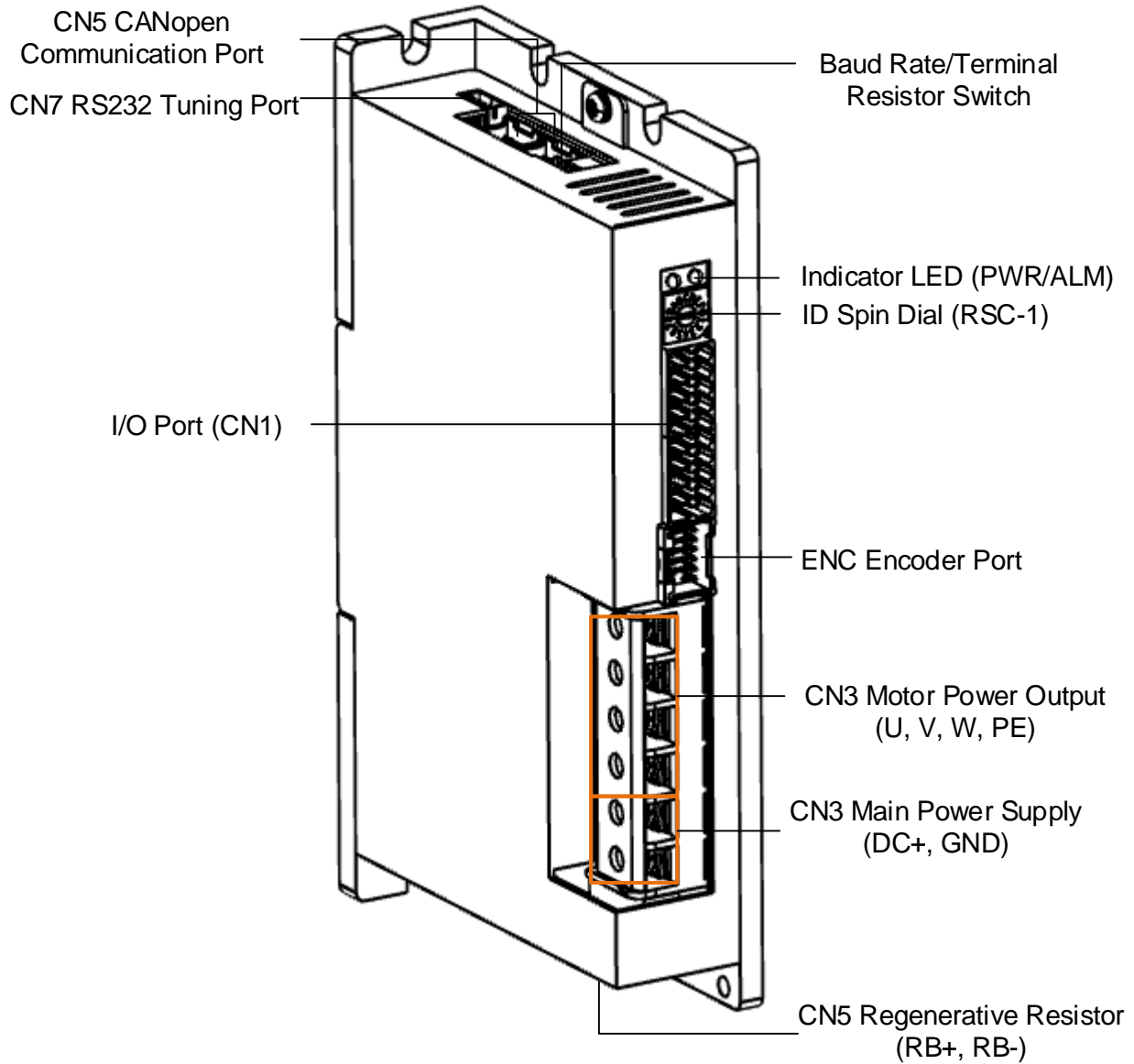

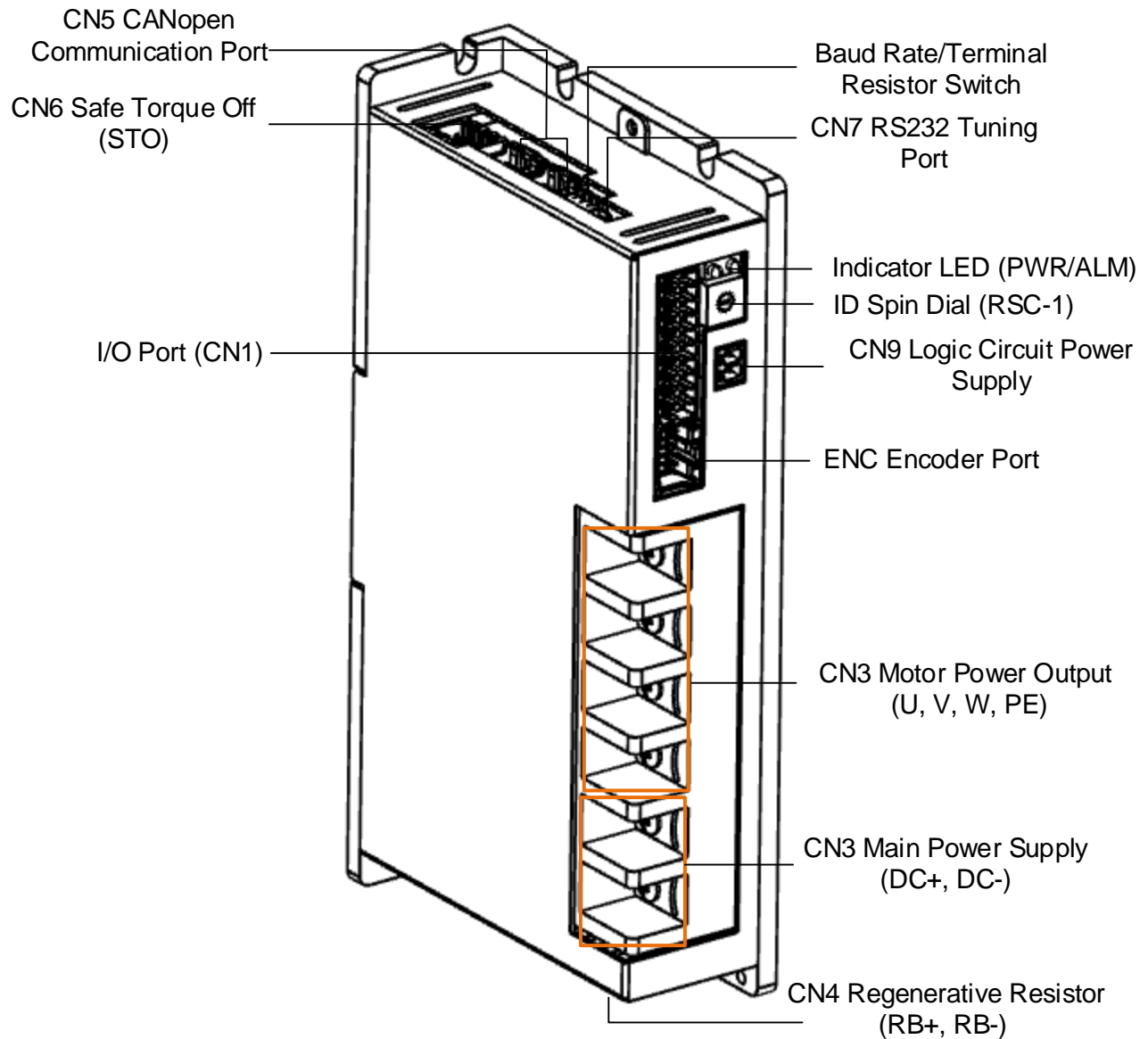
LD2-CAN 7040B/7060B

Connector	Label
CN1	I/O signal port
CN3	Motor power output (U, V, W, PE) Main Power Supply (DC+, DC-)
CN4	Regenerative resistor port (RB+, RB-)
CN5	CANopen Communication port
CN6	Safe Torque Off (STO) port
CN7	RS232 tuning port
CN9	Logic circuit power supply port
ENC	Motor encoder feedback
SW	Baud rate/Terminal resistor switch
RSC	ID spin dial

2.4.1 CN1 I/O Signal Port

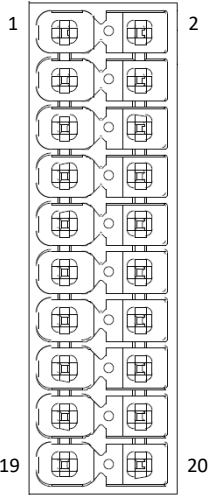
Diagram	CN	Pin	Signal	Description
	CN1	1	NC	NA
		2	NC	
		3	NC	
		4	NC	
		5	COM_IN	Common DI
		6	DI3	Emergency stop
		7	DI4	Homing switch
		8	DI5	Positive limit
		9	DI6	Negative limit
		10	NC	NA
		11	NC	
		12	A+	Encoder signal A output
		13	A-	
		14	B+	Encoder signal B output
		15	B-	
		16	BR+	Holding brake output positive and negative terminal, max current output: 1A
		17	BR-	
		18	DO1	Alarm output, current output <100mA
		19	DO2	Servo ready, current output <100mA
		20	COM_OUT	Common output

I/O Signal Wiring Diagram

- DI3-DI6 supports NPN and PNP configuration. Recommended to use an external control signal power supply of 12-24VDC.
- DO1-DO2 are single ended outputs with 100mA current output that supports NPN and PNP configuration. Recommended to use an external power supply of 24VDC. If the load is an inductive load such as a relay, please install freewheeling diodes on both ends of the load in parallel. If the diode is connected in reverse, it might cause damage to the driver.

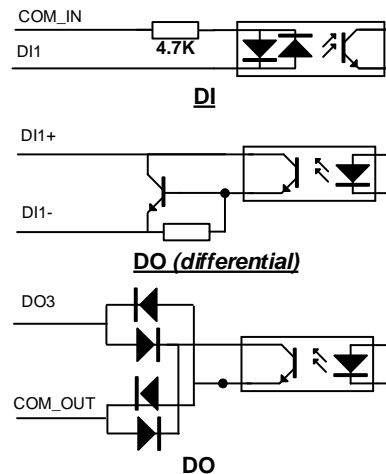

CN1 control signal cable selection

To ensure I/O signal to not be affected by electromagnetic interference, a **shielded cable** is recommended for this application.

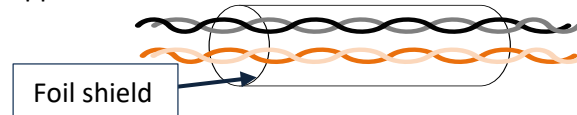

Cables for different analogue signals should be using isolated shielded cable while cables for digital signals should be shielded twisted pair cable. Cables for CN1 connectors should be 24-28AWG in diameter.

2.4.2 CN3/CN4 Power supply & Regenerative Resistor Port

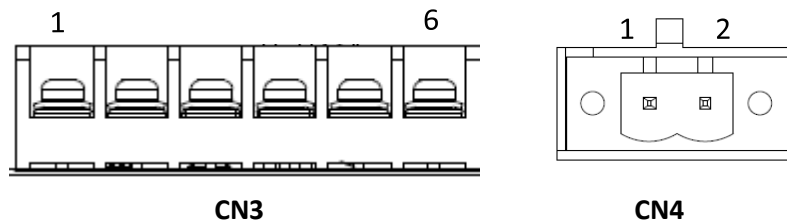

Port	Pin	Signal	Description
CN3	1	DC+	DC Power Supply positive and negative terminals
	2	DC-	
	3	PE	U, V, W, PE terminals for motor
	4	U	
	5	V	
	6	W	
CN4	1	DC+	DC Power Supply positive and negative terminals
	2	DC-	

2.4.3 CN5 CANopen Communication Port

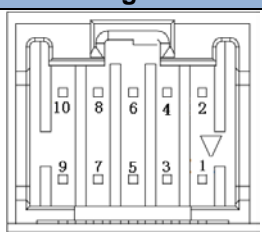
Port	Diagram	Pin	Signal	Label
CN5		1	CANH	CANopen H terminal
		3	CANL	CANopen L terminal
		5	GND	Power supply ground
		Others	NC	10 pins are not applicable

Note:

- Molex 55959-1030 Connector Header (Driver side)
- Molex 51353-1000 10-pin rectangle connector 1pcs for each axis (Provided)
- Molex 56134-9000 female terminal reel 10pcs for each axis (Provided)

2.4.4 CN6 Safe Torque Off (STO) Port

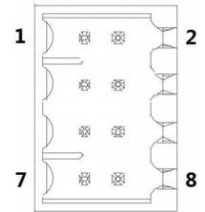
Port	Diagram	Pin	Signal	Description	Remarks
CN6		1	5V	24v power supply	Connect to SF1 and SF2 when not in use. Do not use to supply power.
		2	GND	Reference ground	
		3	STO1+	STO 1 positive input	When SF1 = OFF or SF2 = OFF, STO is enabled.
		4	STO1-	STO 1 negative input	
		5	STO2+	STO 2 positive input	
		6	STO2-	STO 2 negative input	
		7	EDM+	External monitoring device (EDM) with differential double	When SF1 = OFF and SF2 = OFF, EDM = ON
		8	EDM-		

Introduction to Safe Torque Off (STO)

Function: Cut off motor current supply physically (through mechanical means)

STO module (CN6 connector) consists of 2 input channels. It cuts off the motor current supply by blocking of PWM control signal from the power module. When the motor current is cut off, the motor will still move under inertia and stops gradually.

The STO function is set up ready to be used by factory default. Please remove STO connector if it is not needed.

STO functional principle

STO module cuts off the motor current supply and stops motor gradually by blocking of PWM control signal from the power module through 2 isolated circuits. When a STO error occurs, the actual status of STO can be determined by the EDM status feedback.

SF1 Input Status	SF2 Input Status	EDM Output Status	PWM control signal	Alarm code
ON	ON	OFF	Normal	-
ON	OFF	OFF	Blocked	Er 1c2
OFF	ON	OFF	Blocked	Er 1c1
OFF	OFF	ON	Blocked	Er 1c0

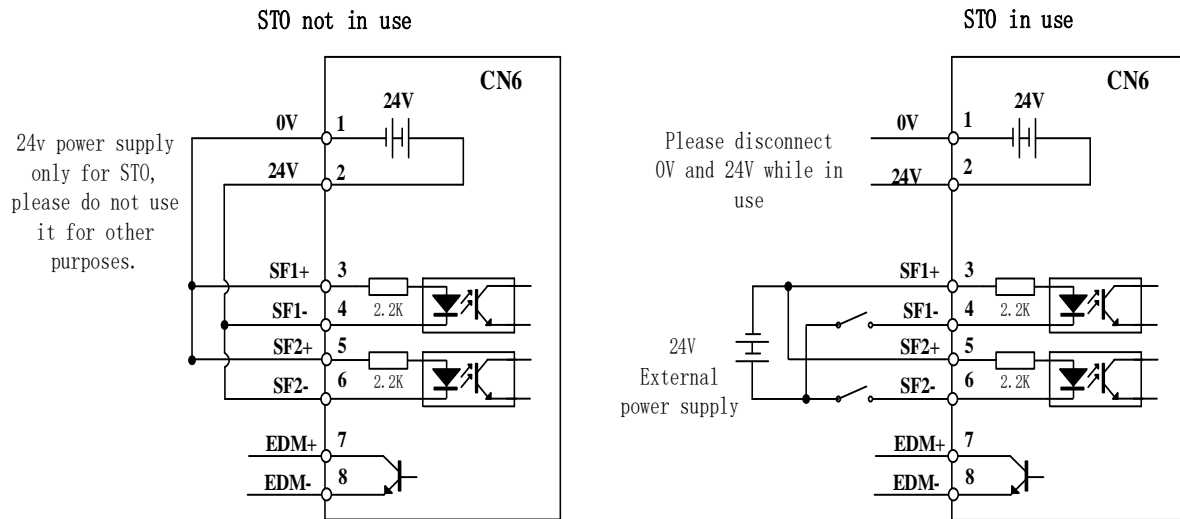
STO wiring diagram

- Please take precautions when enabling STO functions as servo drive will lose control over the motion of the motor. Motor might dropped under gravitational pull (vertically mounted load) or moved when external forces are applied to it. Alternatively, motor with holding brake can be chosen.
- STO is not meant to cut off the power supply of the servo drivers and motors completely. Please power off and wait for a few minutes before starting maintenance work.
- It is recommended to use an isolated power supply for STO signal input as any current leakage might cause STO malfunction.

2.4.5 CN7 RS232 Tuning Port

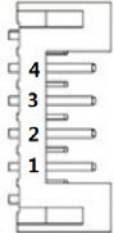
Port	Diagram	Pin	Signal
CN7 & CN8		1	5V
		2	TX
		3	GND
		4	RX

LD2-CAN Series DC Servo Drive can be connected to Motion Studio 2 for parameters tuning and data monitoring using **CABLE-PC-1**.

2.4.6 CN9 Logic Circuit Power Supply Port

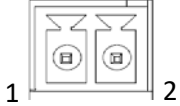
Port	Diagram	Pin	Signal	Description
CN9		1	24V	24V positive terminal
		2	GND	24V negative terminal

LD2-CAN7040B/7060B dual-axis DC servo drives include an optional logic circuit power supply port. When main power supply is cut, logic circuit power supply port can be connected to realize:

1. Partially functional DSP
2. Holding brake output to directly control the status of motor holding brake

2.4.7 ENC Encoder Feedback Port

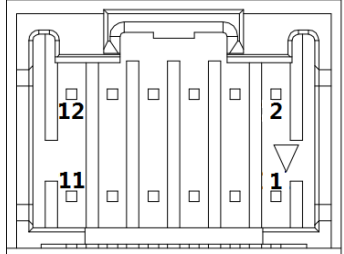
Port	Diagram	Pin	Signal	Description
CN2		1	Foil Shield	Encoder cable shielded layer
		2	HU	Motor Hall U signal
		3	HW	Motor Hall W signal
		4	HV	Motor Hall V signal
		5	VCC	5V power supply from driver. Only for encoder
		6	GND	
		7	EZ+/D+	Encoder Z phase positive signal / encoder positive terminal
		8	EZ-/D-	Encoder Z phase negative signal / encoder negative terminal
		9	EB+	Encoder B phase positive signal
		10	EB-	Encoder B phase negative signal
		11	EA+	Encoder A phase positive signal
		12	EA-	Encoder B phase negative signal

Note:

- Molex 55959-1230 Connector Header (Driver side)
- Molex 51353-1200 12-pin rectangle connector 1pcs for each axis (Provided)
- Molex 56134-9000 female terminal reel 12pcs for each axis (Provided)

2.4.8 ID spin dial RSC

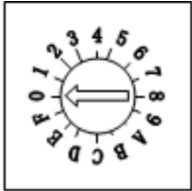
	Diagram	Bit	CAN address	Bit	CAN address
RCS		0	Pr0.23 Default : 16	8	8
		1	1	9	9
		2	2	A	10
		3	3	B	11
		4	4	C	12
		5	5	D	13
		6	6	E	14
		7	7	F	15

2.4.9 Baud rate/Terminal resistor switch SW

	Diagram	CAN_ID (High Bit)	SW1	SW2	Baud rate	SW3	SW4	SW5	Terminal resistor	SW6
SW		0	OFF	OFF	Pr0.24 Default: 1MHz	OFF	OFF	Reserved	Disconnected (CAN)	OFF
					500kHz	ON	OFF			
		1	ON	ON	250kHz	OFF	ON		Connected (CAN)	ON
					125kHz	ON	ON			

2.5 Cable Selection

2.5.1 Motor Power Cable

Motor winding power cable

- Wire length available: 0.5m, 1.5m, 3m, 5m, 7m and 10m.
- Connectors type available: SP21 connector
- Please contact Leadshine sales team or any Leadshine certified local retailers for any customized needs.

M: Length of the cable

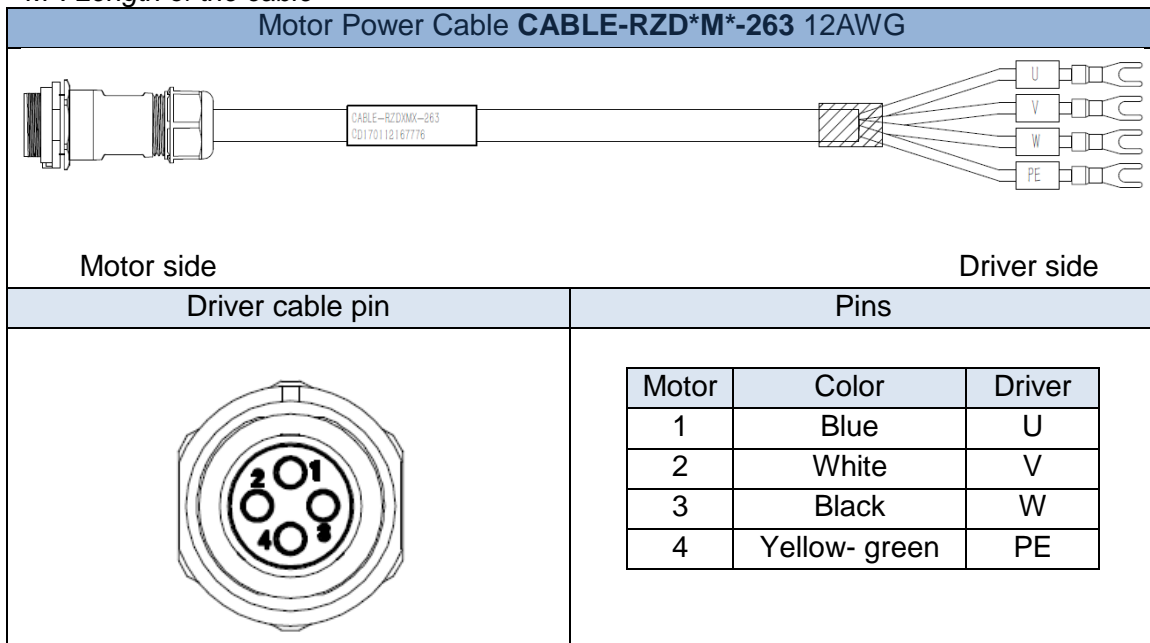

- Recommended wire diameter for each drive

Drive	Wiring diameter (mm ² /AWG)		
	DC+, DC-	UVW	PE
LD2-CAN7005B	AWG18	AWG18	AWG18
LD2-CAN7010B	AWG16	AWG16	AWG16
LD2-CAN7015B	AWG14	AWG16	AWG16
LD2-CAN7020B	AWG12	AWG12	AWG12
LD2-CAN7030B	AWG10	AWG10	AWG10
LD2-CAN7040B	AWG8	AWG8	AWG8
LD2-CAN7060B	AWG6	AWG6	AWG6

- **Grounding:** Grounding wire should be thicker. Ground PE terminal of servo drive and servo motor together with resistance <100 Ω.
- Connect a line filter to power supply to reduce electromagnetic interference.
- Please install a fuseless circuit breaker to cut off power supply in time when the driver fails.

2.5.2 Motor Encoder Cable

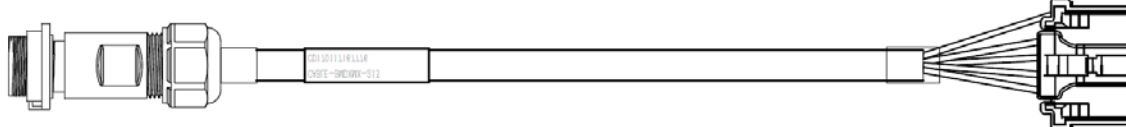
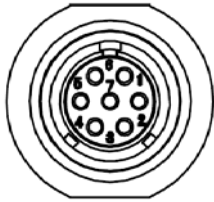
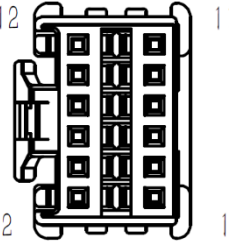
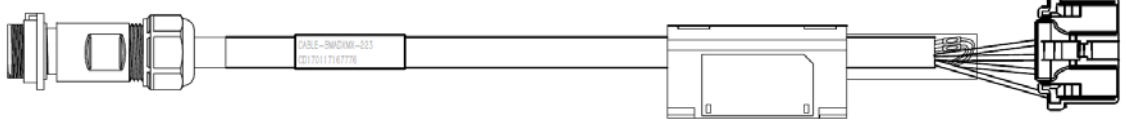
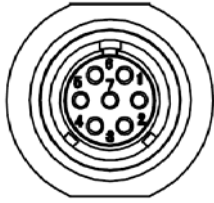
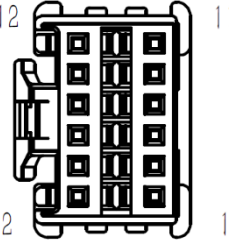
CABLE-BMD*M*-213 for single turn encoder																																				
		<p>Motor side Driver side</p>																																		
Motor cable pin		Pin																																		
 <p>Motor side</p>	 <p>Driver side</p>	<table border="1"> <thead> <tr> <th>Color</th> <th>Signal</th> <th>Motor</th> <th>Drive</th> </tr> </thead> <tbody> <tr> <td>Braid</td> <td>Shield</td> <td>1</td> <td>1</td> </tr> <tr> <td>Red</td> <td>+5V</td> <td>2</td> <td>5</td> </tr> <tr> <td>Red-white</td> <td>GND</td> <td>3</td> <td>6</td> </tr> <tr> <td>Blue</td> <td>SD+</td> <td>4</td> <td>7</td> </tr> <tr> <td>Blue-Black</td> <td>SD-</td> <td>5</td> <td>8</td> </tr> </tbody> </table>	Color	Signal	Motor	Drive	Braid	Shield	1	1	Red	+5V	2	5	Red-white	GND	3	6	Blue	SD+	4	7	Blue-Black	SD-	5	8										
Color	Signal	Motor	Drive																																	
Braid	Shield	1	1																																	
Red	+5V	2	5																																	
Red-white	GND	3	6																																	
Blue	SD+	4	7																																	
Blue-Black	SD-	5	8																																	
CABLE-BMAD*M*-223 with battery kit for multiturn absolute encoder																																				
		<p>Motor side Driver side</p>																																		
Motor cable pin		Pin																																		
 <p>Motor side</p>	 <p>Driver side</p>	<table border="1"> <thead> <tr> <th>Color</th> <th>Signal</th> <th>Motor</th> <th>Drive</th> </tr> </thead> <tbody> <tr> <td>Braid</td> <td>Shield</td> <td>1</td> <td>1</td> </tr> <tr> <td>Black</td> <td>+5V</td> <td>2</td> <td>5</td> </tr> <tr> <td>Black-White</td> <td>GND</td> <td>3</td> <td>6</td> </tr> <tr> <td>Blue</td> <td>SD+</td> <td>4</td> <td>7</td> </tr> <tr> <td>Blue-Black</td> <td>SD-</td> <td>5</td> <td>8</td> </tr> <tr> <td>Red</td> <td>BAT+</td> <td>6</td> <td>-</td> </tr> <tr> <td>Red-White</td> <td>BAT-</td> <td>7</td> <td>-</td> </tr> </tbody> </table>	Color	Signal	Motor	Drive	Braid	Shield	1	1	Black	+5V	2	5	Black-White	GND	3	6	Blue	SD+	4	7	Blue-Black	SD-	5	8	Red	BAT+	6	-	Red-White	BAT-	7	-		
Color	Signal	Motor	Drive																																	
Braid	Shield	1	1																																	
Black	+5V	2	5																																	
Black-White	GND	3	6																																	
Blue	SD+	4	7																																	
Blue-Black	SD-	5	8																																	
Red	BAT+	6	-																																	
Red-White	BAT-	7	-																																	

2.5.3 Motor Brake Cable

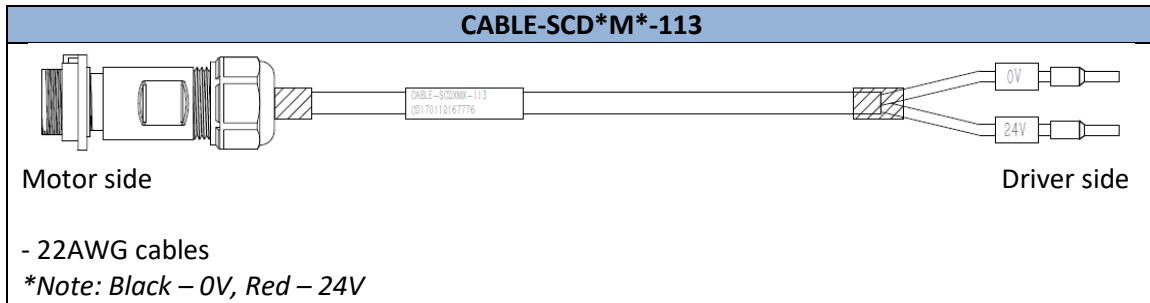

2.5.4 Drive Communication Cable

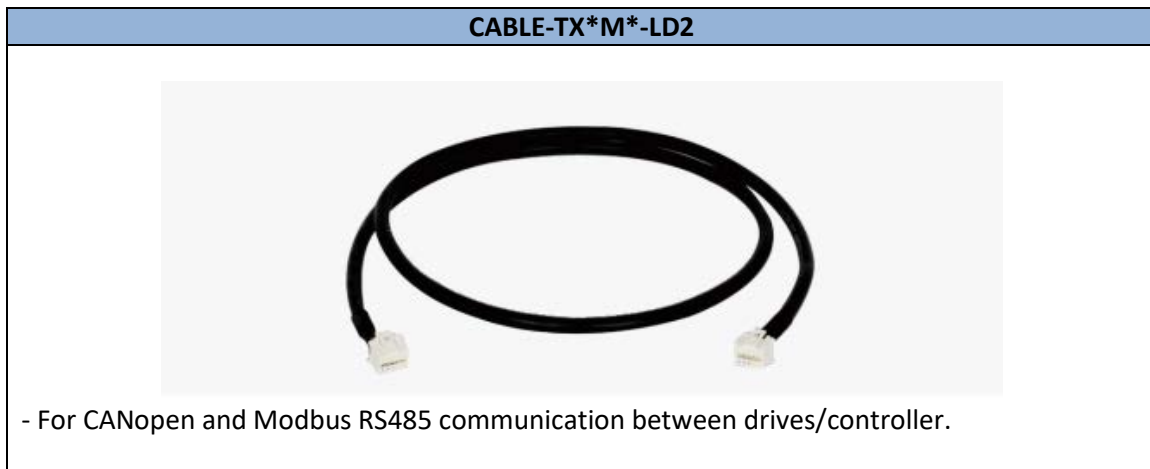

2.5.5 Tuning Cable

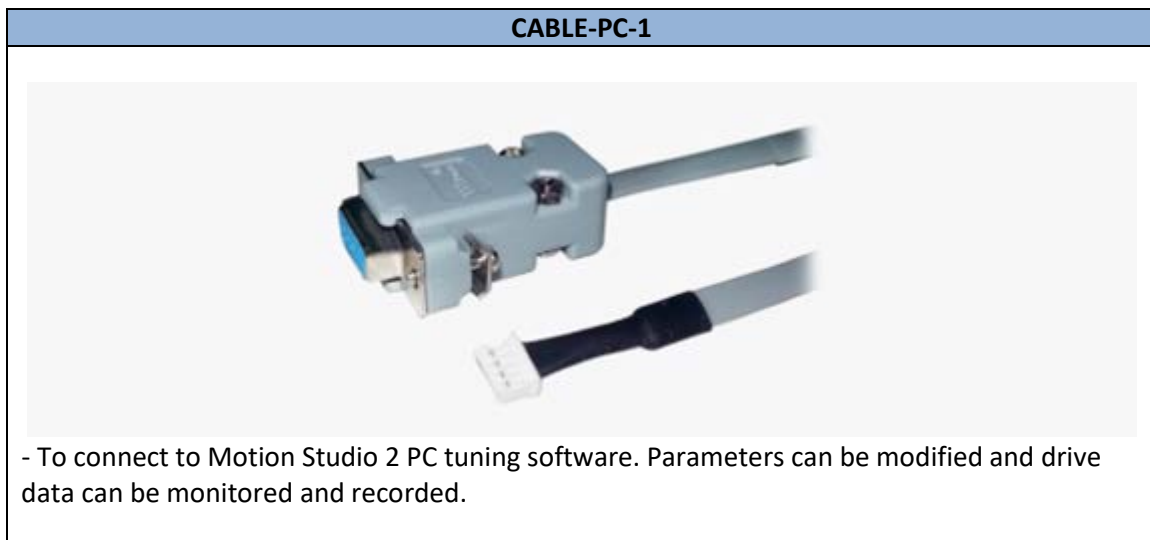

2.6 Regenerative Resistor Selection

The use of regenerative resistor

When the motor opposes the direction of rotation as in deceleration or vertical axis escalation, part of the regenerative energy will be delivered back to the driver. This energy will first be stored in internal capacitors of the driver. When the energy stored in the capacitors reach the maximum capacity, a regenerative resistor is required the excessive energy to prevent over-voltage.

Calculation of regenerative resistance under normal operation

Steps:

1. Determine if driver comes with a regenerative resistor. If not, please prepare a regenerative resistor with resistance value higher than might be required.
2. Monitor the load rate of the regenerative resistor using front panel (d14). Set the driver on high velocity back and forth motions with high acceleration/deceleration.
3. Please make sure to obtain the value under following conditions: Driver temperature < 60°C, d14<80(Won't trigger alarm), Regenerative resistor is not fuming, No overvoltage alarm(Err120).

$$P_b(\text{Regenerative power rating}) = \text{Resistor power rating} \times \text{Regenerative load rate (\%)}$$

Please choose a regenerative resistor with power rating P_r about **2-4 times the value of P_b** in considered of harsh working conditions and some 'headroom'.

If the calculated P_r value is less than internal resistor power rating, external resistor is not required.

$$R(\text{Max. required regenerative resistance}) = (380^2 - 370^2)/P_r$$

Problem diagnostics related to regenerative resistor:

- If driver temperature is high, reduce regenerative energy power rating or use an external regenerative resistor.
- If regenerative resistor is fuming, reduce regenerative energy power rating or use an external regenerative resistor with higher power rating.
- If d14 is overly large or increasing too fast, reduce regenerative energy power rating or use an external regenerative resistor with higher power rating.
- If driver overvoltage alarm (Er120) occurs, please use an external regenerative resistor with lower resistance or connect another resistor in parallel.

Please take following precautions before installing an external regenerative resistor.

1. Please set the correct resistance value in Pr0.16 and resistor power rating Pr0.17 for the external regenerative resistor.
2. Please ensure the resistance value is higher or equals to the recommended values in table 2-3. Regenerative resistors are generally connected in series but they can also be connected in parallel to lower the total resistance.
3. Please provided enough cooling for the regenerative resistor as it can reach above 100°C under continuous working conditions.
4. The min. resistance of the regenerative resistor is dependent on the IGBT of the regenerative resistor circuit. Please refer to the table above.

Theoretical selection of regenerative resistor

Without external loading torque, the need for an external regenerative resistor can be determined as the flow chart below

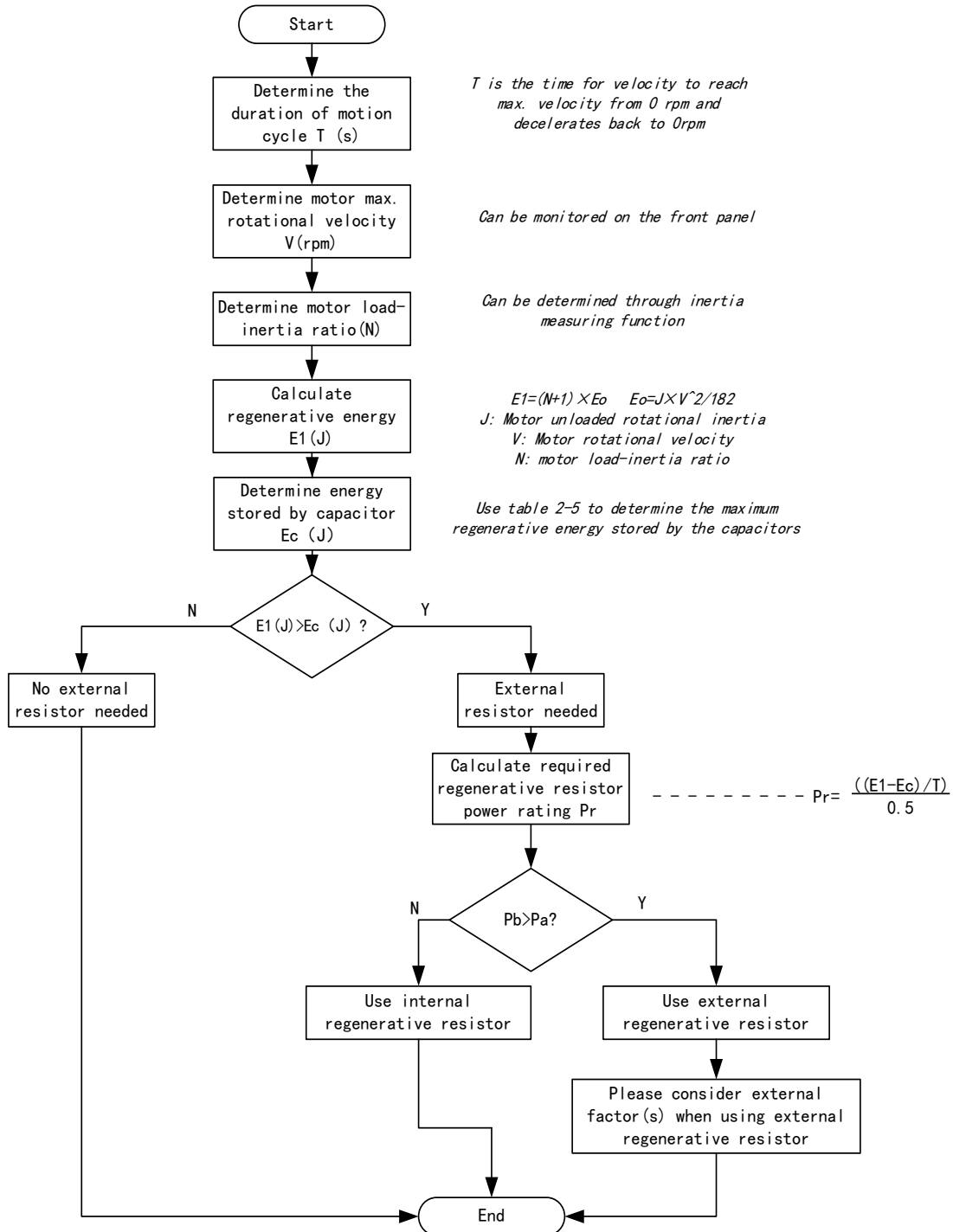
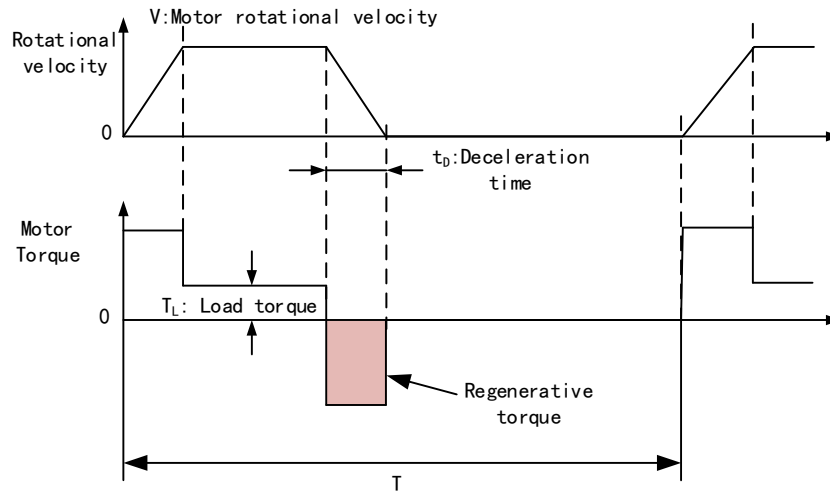

Diagram below shows the acceleration and deceleration cycle periods and the regenerative torque that occurs during the process.



Steps to calculate capacity of regenerative resistor

Steps	Calculation	Symbol	Formula
1	Servo system regenerative energy	E_1	$E_1 = (N+1) \times J \times V^2 / 182$
2	Depleted energy from loss of load system during acceleration	E_L	$E_L = (\pi/60) V \times T_L \times t_D$ <i>If loss is not determined, please assume $E_L = 0$.</i>
3	Depleted energy due to motor coil resistance.	E_M	$E_M = (U^2/R) \times t_D$ R= coil resistance, U = operating voltage <i>If R is not determined, please assume $E_M = 0$.</i>
4	Energy stored by internal DC capacitors	E_C	Please refer to table 2-5
5	Depleted energy due to regenerative resistance	E_K	$E_K = E_1 - (E_L + E_M + E_C)$, If loss is ignored, $E_K = E_1 - E_C$
6	Required power rating of regenerative resistor	P_r	$P_r = E_K / (0.5 \times T)$

Note:

- 0.5 in the calculation for P_r represent 50% load rate of regenerative resistor.
- E_1 - E_K : Energy(Joule) T_L : Load torque(Nm) V : Motor velocity(rpm/min)
 P_r : Regenerative resistor power rating t_D : Deceleration stop time(s)
 J : Rotor inertia (kgm^2) T : Motor cycle time(s) N : Ratio of load inertia and rotor inertia

Internal capacitor capacity and rotor inertia

LD2 Drives	Servo motor	Rotor Inertia ($\times 10^{-4}\text{kg}\cdot\text{m}^2$)	Max. regenerative energy stored in capacitor $E_c(\text{J})$
750W (7020B)	LVM8075V48FH-M17	1.5	2.26
1000W (7030B)	LVM80100V48FH-M17	1.79	2.26

There are motors with low, medium and high inertia. Different motor models have different rotor inertia. Please refer to product catalogue for more information on rotor inertia. Please cut down 30%-40% of load rate if the product is used in harsh environment with less than ideal heat dissipation measures.

Recommended regenerative resistor specification for each drives

Drives	Resistance (Ω)	Power rating(W)	Min. Resistance(Ω)
LD2-CAN7005B	10	30	5
LD2-CAN7010B	10	50	5
LD2-CAN7015B	10	50	5
LD2-CAN7020B	10	100	5
LD2-CAN7030B	10	100/150	5
LD2-CAN7040B	10	150/200	5
LD2-CAN7060B	10	150/200	5

Note:

1. Use 10 Ω /100W resistor for test operation and make sure: Drive temperature $d33 < 60^\circ\text{C}$, dynamic brake is not in alarm mode (Braking rate $d14 < 80$), brake resistor is not overheated, drive has no overcurrent alarm.
2. If drive temperature is too high, increase power rating of regenerative resistor or reduce drive power.
3. If brake resistor is overheated, reduce drive power or use regenerative resistor with higher resistance.
4. If $d14$ is too high, reduce drive power or use regenerative resistor with higher resistance and power ratings.
5. External torque might cause regenerative energy to flow back into drive. During normal operation, torque output in the same direction as rotational direction but if external torque exists, directions might oppose and in this case, regenerative resistor with higher resistance may be required.

Chapter 3 Parameter

3.1 Parameter List

- Panel Display as follows:

PR0.00

classify and code  number

- Parameter Valid mode Description
 HM: Valid in homing mode
 PP: Valid in profile position mode
 PV: Valid in profile velocity mode
 PT: Valid in profile torque mode
 F: Valid in all modes

3.1.1 Servo drive parameter

Class	Label	CANopen Address	Parameter	Activation	Valid Mode				
					PP	PV	HM	PT	F
[Class]	Model-following bandwidth	2000h	PR_000	Immediate					F
	Control Mode Settings	2001h	PR_001	After restart					F
	Real time Auto Gain Adjusting	2002h	PR_002	Immediate					F
	Real time auto stiffness adjusting	2003h	PR_003	Immediate					F
	Inertia ratio	2004h	PR_004	Immediate					F
	Rotational direction	2006h	PR_006	After restart					F
	Command pulse counts per revolution	2008h	PR_008	After restart	PP	PV		HM	
	1 st Torque Limit	2013h	PR_013	Immediate					F
	Excessive Position Deviation Settings	2014h	PR_014	Immediate	PP			HM	
	Absolute Encoder settings	2015h	PR_015	After restart					F
	Regenerative resistance	2016h	PR_016	Immediate					F
	Regenerative resistor power rating	2017h	PR_017	Immediate					F
	Vibration suppression								
	Friction compensation setting	2019h	PR_019	Immediate					F
	CAN node	2023h	PR_023	After restart					F
	CAN Baud rate	2024h	PR_024	After restart					F
	1 st position loop gain	2100h	PR_100	Immediate	PP			HM	
	1 st velocity loop gain	2101h	PR_101	Immediate					F
	1 st Integral Time Constant of Velocity Loop	2102h	PR_102	Immediate					F

Class	Label	CANopen Address	Parameter	Activation	Valid Mode				
[Class 1] Gain adjustments	1 st velocity detection filter	2103h	PR_103	Immediate					F
	1 st Torque Filter Time Constant	2104h	PR_104	Immediate					F
	2 nd Position Loop Gain	2105h	PR_105	Immediate	PP			HM	
	2 nd velocity loop gain	2106h	PR_106	Immediate					F
	2 nd Integral Time Constant of Velocity Loop	2107h	PR_107	Immediate					F
	2 nd velocity detection filter	2108h	PR_108	Immediate					F
	2 nd Torque Filter Time Constant	2109h	PR_109	Immediate					F
	Velocity feed forward gain	2110h	PR_110	Immediate	PP			HM	
	Velocity feed forward filter time constant	2111h	PR_111	Immediate	PP			HM	
	Torque feed forward gain	2112h	PR_112	Immediate	PP	PV		HM	
	Torque feed forward filter time constant	2113h	PR_113	Immediate	PP	PV		HM	
	Position control gain switching mode	2115h	PR_115	Immediate					F
	Position control gain switching level	2117h	PR_117	Immediate					F
	Hysteresis at position control switching	2118h	PR_118	Immediate					F
	Position gain switching time	2119h	PR_119	Immediate					F
	Speed regulator - kr	2123h	PR_123	Immediate					F
	Speed regulator - km	2124h	PR_124	Immediate					F
	Speed regulator - kd	2125h	PR_125	Immediate					F
	Speed regulator - kd filter	2126h	PR_126	Immediate					F
	1 st position loop integral time	2128h	PR_128	Immediate					F
2 nd position loop integral time	2130h	PR_130	Immediate					F	
Special function register	2137h	PR_137	Immediate					F	
[Class 2] Vibration Suppression	Adaptive filtering mode settings	2200h	PR_200	Immediate					F
	1 st notch frequency	2201h	PR_201	Immediate					F
	1 st notch bandwidth selection	2202h	PR_202	Immediate					F
	1 st notch depth selection	2203h	PR_203	Immediate					F
	2 nd notch frequency	2204h	PR_204	Immediate					F
	notch bandwidth selection	2205h	PR_205	Immediate					F
	2 nd notch depth selection	2206h	PR_206	Immediate					F
	3 rd notch frequency	2207h	PR_207	Immediate					F
3 rd notch bandwidth selection	2208h	PR_208	Immediate					F	

Class	Label	CANopen Address	Parameter	Activation	Valid Mode				
	3 rd notch depth selection	2209h	PR_209	Immediate					F
	1 st damping frequency	2214h	PR_214	Immediate					F
	1 st filter	2215h	PR_215	Immediate					F
	Position command smoothing filter	2222h	PR_222	Keep stop					F
	Position command FIR filter	2223h	PR_223	Disable	PP			HM	
[Class 3] Velocity/ Torque control	Internal/External settings of velocity settings	2300h	PR_300	Immediate					F
	Velocity command input inversion	2303h	PR_303	Immediate		PV			
	1 st speed of velocity setting	2304h	PR_304	Immediate		PV			
	2 nd speed of velocity setting	2305h	PR_305	Immediate		PV			
	3 rd speed of velocity setting	2306h	PR_306	Immediate					F
	4 th speed of velocity setting	2307h	PR_307	Immediate					F
	5 th speed of velocity setting	2308h	PR_308	Immediate					F
	6 th speed of velocity setting	2309h	PR_309	Immediate					F
	7 th speed of velocity setting	2310h	PR_310	Immediate					F
	8 th speed of velocity setting	2311h	PR_311	Immediate					F
	Acceleration time settings	2312h	PR_312	Immediate		PV			
	Deceleration time settings	2313h	PR_313	Immediate		PV			
	Sigmoid acceleration/deceleration settings	2314h	PR_314	Disable		PV			
	Zero speed clamp level	2316h	PR_316	Immediate					F
	Internal/External settings of torque	2317h	PR_317	Immediate		PV			
	Torque command direction selection	2320h	PR_320	Immediate		PV			
	Velocity limit value in torque mode	2321h	PR_321	Immediate					F
	Torque limit value in torque mode	2322h	PR_322	Immediate					F
	Maximum motor rotational velocity	2324h	PR_324	Immediate					F
		Input selection DI1	2400h	PR_400	Immediate				
Input selection DI2		2401h	PR_401	Immediate					F
Input selection DI3		2402h	PR_402	Immediate					F

Class	Label	CANopen Address	Parameter	Activation	Valid Mode			
[Class 4] I/O interface	Input selection DI4	2403h	PR_403	Immediate				F
	Output selection D01	2410h	PR_410	Immediate				F
	Output selection D02	2411h	PR_411	Immediate				F
	Output selection D03	2412h	PR_412	Immediate				F
	Positioning complete range	2431h	PR_431	Immediate				F
	Positioning complete output setting	2432h	PR_432	Immediate	PP		HM	
	INP positioning delay time	2433h	PR_433	Immediate				F
	Zero speed	2434h	PR_434	Immediate				F
	Velocity coincidence range	2435h	PR_435	Immediate				F
	Arrival velocity	2436h	PR_436	Immediate				F
	Motor power-off delay time	2437h	PR_437	Immediate				F
	Delay time for holding brake release	2438h	PR_438	Immediate				F
	Holding brake activation speed	2439h	PR_439	Immediate				F
	Emergency stop function	2443h	PR_443	Immediate	PP		HM	
	[Class 5] Extended parameters	Driver prohibition input settings	2504h	PR_504	Immediate			
Servo-off mode		2506h	PR_506	After restart				F
Main power-off detection time		2508h	PR_508	Immediate				F
Servo-off due to alarm mode		2510h	PR_510	After restart				F
Servo braking torque setting		2511h	PR_511	Immediate				F
Overload level setting		2512h	PR_512	Immediate				F
Overspeed level settings		2513h	PR_513	Immediate				F
I/O digital filter		2515h	PR_515	Immediate				F
Position unit settings		2520h	PR_520	Disable				F
Torque limit selection		2521h	PR_521	Immediate				F
2 nd torque limit		2522h	PR_522	Immediate				F
Positive torque warning threshold		2523h	PR_523	Immediate	PP		HM	
Negative torque warning threshold		2524h	PR_524	Immediate				F
Torque warning threshold alarm delay time		2537h	PR_537	After restart				F
	JOG trial run velocity command	2604h	PR_604	Immediate				F
	Position 3 rd gain valid time	2605h	PR_605	Immediate	PP		HM	
	Position 3 rd gain scale factor	2606h	PR_606	Immediate	PP		HM	
	Torque command	2607h	PR_607	Immediate				F

Class	Label	CANopen Address	Parameter	Activation	Valid Mode			
[Class 6] Special Parameters	additional value							
	Positive direction torque compensation value	2608h	PR_608	Immediate				F
	Negative direction torque compensation value	2609h	PR_609	Immediate				F
	Current response settings	2611h	PR_611	Immediate				F
	Encoder zero position torque offset limit	2612h	PR_612	Immediate				F
	Max. time to stop after disabling	2614h	PR_614	Immediate				F
	Trial run distance	2620h	PR_620	Immediate				F
	Trial run waiting time	2621h	PR_621	Immediate				F
	No. of trial run cycles	2622h	PR_622	Immediate				F
	Trial run acceleration	2625h	PR_625	Immediate				F
	Trial run mode	2626h	PR_626	Immediate				F
	Special function registry 2	2638h	PR_638	Immediate				F
	Blocked rotor alarm delay time	2657h	PR_657	Immediate				F
	Homing position (16-bit high)	2658h	PR_658	Immediate				F
	Homing position (16-bit Low)	2659h	PR_659	Immediate				
	Z signal holding time	2661h	PR_661	Immediate				F
	Overload threshold	2662h	PR_662	Immediate				
	Absolute multiturn data upper limit	2663h	PR_663	After restart				F

Class	Label	CANopen Address	Parameter	Activation	Valid Mode			
[Class 7] Motor Parameters	Current loop gain	2700h	PR_700	Immediate				F
	Current loop integral time	2701h	PR_701	Immediate				F
	Motor rotor initial angle compensation	2702h	PR_702	Immediate				F
	Current differential coefficient	2703h	PR_703	Immediate				F
	Death zone compensation coefficient	2704h	PR_704	Immediate				F
	Motor pole pairs	2705h	PR_705	Immediate				F
	Motor phase resistance	2706h	PR_706	Immediate				F
	Motor D/Q inductance	2707h	PR_707	Immediate				F
	Motor back EMF coefficient	2708h	PR_708	Immediate				F
	Motor torque coefficient	2709h	PR_709	Immediate				F

Class	Label	CANopen Address	Parameter	Activation	Valid Mode				
	Motor rated rotational speed	2710h	PR_710	Immediate					F
	Motor maximum speed	2711h	PR_711	Immediate					F
	Motor rated current	2712h	PR_712	Immediate					F
	Motor rotor inertia	2713h	PR_713	Immediate					F
	Motor power rating	2714h	PR_714	Immediate					F
	Motor model	2715h	PR_715	Immediate					F
	Encoder model	2716h	PR_716	Immediate					F
	Motor max. current	2717h	PR_717	Immediate					F
	Encoder precision	2723h	PR_723	Immediate					F
	Internal regenerative energy gain	2728h	PR_728	Immediate					F
	DC bus voltage measuring filter	2729h	PR_729	Immediate					F
	Undervoltage threshold value	2730h	PR_730	Immediate					F
	Regenerative energy control mode settings	2731h	PR_731	Immediate					F
	Regenerative energy on threshold value settings	2732h	PR_732	Immediate					F
	Regenerative energy hysteresis control	2733h	PR_733	Immediate					F
	Overvoltage threshold value	2734h	PR_734	Immediate					F
	Power-on enabling delay time	2748h	PR_748	Immediate					F

3.1.2 Motion parameter starting with object dictionary 6000

Index	Sub-index	Label	Unit	Default	Min	Max	Mode
603F	0	Error code	-	0x0	0x0	0xFFFF	F
6040	0	Control word	-	0x0	0x0	0xFFFF	F
6041	0	Status word	-	0x0	0x0	0xFFFF	F
605A	0	Quick stop option code	-	2	0	7	F
605B	0	Shutdown option code	-	0	0	1	F
605C	0	Disable operation option code	-	0	0	1	F
605D	0	Halt option code	-	1	1	3	F
6060	0	Mode of Operation	-	8	1	11	F
6061	0	Mode of Operation display	-	0	0	10	F
6062	0	Position Demand Value	Command unit	0	- 2147483 648	2147483 647	PP/HM
6063	0	Position Actual Internal Value	Encoder unit	0	- 2147483 648	2147483 647	F
6064	0	Position Actual Value	Command unit	-	- 2147483 648	2147483 647	F
606B	0	Velocity Demand Value	Command unit/s	0	- 2147483 648	2147483 647	PV
606C	0	Velocity Actual Value	Command unit/s	0	- 2147483 648	2147483 647	PP/HM
6071	0	Target Torque	0.001	0	-32768	32767	PT
6072	0	Max Torque	0.001	3000	0	65535	F
6073	0	Max Current	0.001	3000	-	65535	F
6074	0	Torque Demand	0.001	0	-32768	32767	F
6075	0	Motor Rated Current	mA	3000	0	2147483 647	F
6076	0	Motor Rated Torque	mN.m	3000	0	2147483 647	F
6077	0	Torque Actual Value	0.1%	0	-5000	5000	F
6078	0	Current Actual value	0.1%		-5000	5000	
6079	0	DC bus voltage	mV	0	0	2147483 647	F
607A	0	Target position	Command unit	0	- 2147483 648	2147483 647	PP
607C	0	Homing position offset	Command unit	0	- 2147483 648	2147483 647	HM
607D	0	Number of Entries	-	2	0	2	PP
	1	Min. software limit	Command unit	0	- 2147483	2147483 647	PP

					648		
	2	Max. software limit	Command unit	0	- 2147483 648	2147483 647	PP
607E	0	Polarity	-	0x0	0x0	0xFF	F
607F	0	Max Profile Velocity	Command unit /s	214748 3647	0	2147483 647	PP/HM /PV
6080	0	Max Motor Speed	r/min	6000	0	2147483 647	F
6081	0	Profile Velocity	Command unit /s	10000	0	2147483 647	PP
6083	0	Profile Acceleration	Command unit /s ²	10000	1	2147483 647	PP/PV/
6084	0	Profile Deceleration	Command unit /s ²	10000	1	2147483 647	PP/PV
6085	0	Quick Stop Deceleration	Command unit /s ²	100000 00	1	2147483 647	PP/PV/ HM
6087	0	Torque Slope	0.001/s	5000	1	2147483 647	PT
608F	0	Number of Entries	-	2	0	2	F
	1	Encoder Increments	Encoder unit	10000	1	2147483 647	F
	2	Motor Revolutions	r	1	1	2147483 647	F
6091	0	Number of Entries	-	2	0	2	F
	1	Motor Revolutions	r	1	1	2147483 647	F
	2	Shaft Revolutions	r	1	1	2147483 647	F
6092	0	Number of Entries	-	2	0	2	F
	1	Feed	Command unit/r	10000	1	2147483 647	F
	2	Shaft Revolutions	r	1	1	2147483 647	F
6098	0	Homing method	-	19	-6	37	HM
6099	0	Number of Entries	-	2	0	2	F
	1	Speed During Search For Switch	Command unit /s	10000	0	2147483 647	HM
	2	Speed During Search For Zero	Command unit /s	5000	0	2147483 647	HM
609A	0	Homing acceleration /deceleration	Command unit /s ²	50000 0	1	2147483 647	HM
60C5	0	Max Acceleration	Command unit /s ²	100000 000	1	2147483 647	F
60C6	0	Max Deceleration	Command unit /s ²	100000 000	1	2147483 647	F
60E0	0	Positive Torque Limit	0.001	3000	0	65535	F
60E1	0	Negative Torque Limit	0.001	3000	0	65535	F
60F4	0	Following Error Actual Value	Command unit	0	- 2147483 648	2147483 647	PP/HM
60FA	0	Control Effort	Command	0	-	2147483	PP/HM

			unit /s		2147483 648	647	
60FC	0	Position Demand Internal Value	Encoder unit	0	- 2147483 648	2147483 647	PP/HM
60FD	0	Digital Inputs	-	0x0	0x0	0x7FFFF FFF	F
60FE	0	Number of Entries	-	2	0	2	F
	1	Physical Outputs	-	0x0	0x0	0x7FFFF FFF	F
	2	Bit Mask	-	0x0	0x0	0x7FFFF FFF	F
60FF	0	Target velocity	Command unit /s	0	- 2147483 648	2147483 647	PV
6502	0	Supported drive modes	-	0x0	0x0	0x7FFFF FFF	F

3.2 Parameter Function

- Panel Display as follows:

PR0.00

classify and code  number

- Parameter valid under following modes
 HM: Homing mode
 PP: Profile position mode
 PV: Profile velocity mode
 PT: Profile torque mode
 F: All modes

3.2.1 【Class 0】 Basic Settings

Pr0.00	Label	Model-following bandwidth			Valid Mode						F
	Range	0~2000	Unit	0.1Hz	Default	0	Index	2000h			
	Activation	Immediate									
Model-following bandwidth, also known as model-following control (MFC), is used to control the position loop to improve the responsiveness to commands, speed up positioning time and reduce following error. The effect is obvious especially in low and medium mechanical stiffness.											
Value		Explanation									
0		Disable the function.									
1		Enable the function to set bandwidth automatically, recommended for most applications. Pr0.00=Pr1.01									
2-9		Invalid									
<i>*Recommended settings for belt application: 30<Pr0.00<100.</i>											

Pr0.01	Label	Control Mode Settings			Valid Mode				F															
	Range	0~8	Unit	—	Default	8	Index	2001h																
	Activation	After restart																						
Set value to use following control modes:																								
<table border="1"> <thead> <tr> <th>Value</th> <th>Content</th> <th>Details</th> </tr> </thead> <tbody> <tr> <td>0</td> <td>Position</td> <td>Only for internal position</td> </tr> <tr> <td>1</td> <td>Velocity</td> <td>Only for internal velocity</td> </tr> <tr> <td>2~7</td> <td>Reserved</td> <td>-</td> </tr> <tr> <td>8</td> <td>CANopen</td> <td>PP/PV/PT/HM</td> </tr> </tbody> </table>										Value	Content	Details	0	Position	Only for internal position	1	Velocity	Only for internal velocity	2~7	Reserved	-	8	CANopen	PP/PV/PT/HM
Value	Content	Details																						
0	Position	Only for internal position																						
1	Velocity	Only for internal velocity																						
2~7	Reserved	-																						
8	CANopen	PP/PV/PT/HM																						

Pr0.02	Label	Real time Auto Gain Adjusting			Valid Mode				F												
	Range	0-2	Unit	—	Default	0	Index	2002h													
	Activation	Immediate																			
Set up the mode of the real time auto gain adjusting.																					
<table border="1"> <thead> <tr> <th>Value</th> <th>Content</th> <th>Details</th> </tr> </thead> <tbody> <tr> <td>0</td> <td>Invalid</td> <td>Auto adjusting invalid</td> </tr> <tr> <td>1</td> <td>Standard</td> <td>Pr0.03 valid. Quick gain adjusting can be achieved by changing Pr0.03 stiffness value. Gain switching is not used in this mode, suitable for applications with requirements for stability.</td> </tr> <tr> <td>2</td> <td>Positioning</td> <td>Pr0.03 valid. Quick gain adjusting can be achieved by changing Pr0.03 stiffness value. This mode is suitable for applications requiring quick positioning. Not recommended for load mounted vertical to ground, or please compensate for the load using Pr6.07</td> </tr> </tbody> </table>										Value	Content	Details	0	Invalid	Auto adjusting invalid	1	Standard	Pr0.03 valid. Quick gain adjusting can be achieved by changing Pr0.03 stiffness value. Gain switching is not used in this mode, suitable for applications with requirements for stability.	2	Positioning	Pr0.03 valid. Quick gain adjusting can be achieved by changing Pr0.03 stiffness value. This mode is suitable for applications requiring quick positioning. Not recommended for load mounted vertical to ground, or please compensate for the load using Pr6.07
Value	Content	Details																			
0	Invalid	Auto adjusting invalid																			
1	Standard	Pr0.03 valid. Quick gain adjusting can be achieved by changing Pr0.03 stiffness value. Gain switching is not used in this mode, suitable for applications with requirements for stability.																			
2	Positioning	Pr0.03 valid. Quick gain adjusting can be achieved by changing Pr0.03 stiffness value. This mode is suitable for applications requiring quick positioning. Not recommended for load mounted vertical to ground, or please compensate for the load using Pr6.07																			

Pr0.03	Label	Real time auto stiffness adjusting			Mode				F
	Range	50 ~ 81	Unit	—	Default	70	Index	2003h	
	Activation	Immediate							
Valid when Pr0.03 = 1,2									
<p style="text-align: center;"> Low ———▶ Mechanical stiffness ———▶ High Low ———▶ Servo gain ———▶ High </p> <div style="border: 1px solid black; padding: 5px; margin: 10px auto; width: 80%; text-align: center;"> 81.80··········70.69.68··········51.50 </div> <p style="text-align: center;"> Low ———▶ Responsiveness ———▶ High </p>									
Lower values ensure better system responsiveness and mechanical stiffness but machine vibration might occur, please set accordingly.									

Pr0.04	Label	Inertia ratio			Mode							F
	Range	0~20000	Unit	%	Default	250	Index	2004h				
	Activation	Immediate										

$$\text{Pr0.04} = (\text{load inertia} / \text{motor rotational inertia}) \times 100\%$$

Notice:

Set inertia ratio according to actual load inertia. When both are uniform, actual motor velocity loop responsiveness and gain settings will be consistent. If inertia ratio is greater than actual value, velocity loop gain settings will be higher and vice versa.

Pr0.06	Label	Rotational direction			Mode							F
	Range	0 ~ 1	Unit	—	Default	0	Index	2006h				
	Activation	After restart										

Used to change the rotational direction of the motor.

Set value	Details
0	Polarity of the command is not inversed. The direction of rotation is consistent with the polarity of command.
1	Polarity of command is inversed. The direction of rotation is opposite to the polarity of command.

Note: Rotational direction of the motor is recommended to be set through object dictionary 607E. However, Pr0.06 has higher priority than object dictionary 607E. 607E only takes effect when Pr0.06 = 0.

Pr0.08	Label	Command pulse counts per revolution			Mode							F
	Range	0~8388608	Unit	P-	Default	0	Index	2008h				
	Activation	After restart										

Pulses per revolution can be set using object dictionary 608F, 6091, 6092. However, Pr0.08 has higher priority.

Pr0.13	Label	1 st Torque Limit			Mode							F
	Range	0~500	Unit	%	Default	300	Index	2013h				
	Activation	Immediate										

1st torque limit is set according to ratio percentage of motor rated current. Do not exceed max driver output current.
Actual torque limit is the smaller value of Pr0.13 and object dictionary 6072

Pr0.14	Label	Excessive Position Deviation Settings			Mode	PP		HM				
	Range	0~500	Unit	0.1rev	Default	30	Index	2014h				
	Activation	Immediate										

Please set threshold value for position deviation accordingly. Default factory setting = 30, Er180 will be triggered if positive deviation is in excess of 3 revolutions.

Pr0.15	Label	Absolute Encoder settings			Mode	PP		HM		
	Range	0~32767	Unit	-	Default	0	Index	2015h		
	Activation	Immediate								
<p>0: Incremental mode: Used as an incremental encoder. Doesn't retain position data on power off. Unlimited travel distance.</p> <p>1: Multiturn linear mode: Used as a multiturn absolute encoder. Retrain position data on power off. For applications with fixed travel distance and no multiturn data overflow.</p> <p>2: Multiturn rotary mode: Used as a multiturn absolute encoder. Retrain position data on power off. Actual data feedback in between 0-(Pr6.63). Unlimited travel distance.</p> <p>3: Single turn absolute mode: Used when travel distance is within 1 revolution of the encoder. Data overflow will trigger alarm.</p> <p>5: Clear multiturn alarm and activate multiturn absolute function. Will switch to multiturn mode once alarm cleared, if remains at 5 after 3s, please solve according to Er153.</p> <p>9: Clear multiturn position, reset multiturn alarm and activate multiturn absolute function. Will switch to multiturn mode once alarm cleared, if remains at 9 after 3s, please solve according to Er153. Please disable axis before setting to 9 and home the axis before using.</p>										

Pr0.16	Label	Regenerative resistance			Mode					F
	Range	40~500	Unit	Ohm	Default	100	Index	2016h		
	Activation	Immediate								
To set resistance value of regenerative resistor										

Pr0.17	Label	Regenerative resistor power rating			Mode					F
	Range	20~5000	Unit	W	Default	50	Index	2017h		
	Activation	Immediate								
<p>To set power rating of regenerative resistor.</p> <p>Pr0.16 and Pr0.17 determines the threshold value of Er 120. Please set accordingly or it might trigger false alarm or damage to servo driver.</p> <p><i>Note: If external regenerative resistor is used, please set according to its labeled power rating.</i></p>										

Pr0.19	Label	Friction compensation setting			Mode					F
	Range	0~1000	Unit	-	Default	0	Index	2019h		
	Activation	Immediate								
<p>Friction compensation setting = 0, default = 1;</p> <p>Friction compensation setting = x, indicating x+1/10000 of friction compensation runway;</p>										

Pr0.23	Label	CANopen node			Mode					F
	Range	0~127	Unit	—	Default	16	Index	2023h		
	Activation	After restart								
Set ID number of the node under CANopen mode										

Pr0.24	Label	CAN Baud rate			Mode						F
	Range	0~10	Unit	—	Default	1	Index	2024h			
	Activation	After restart									
CANopen device Baud rate settings											
	Pr0.24	CAN Baud rate(kHz)		Pr0.24	CAN Baud rate(kHz)						
	0	1000		4	125						
	1	800		5	100						
	2	500		6	50						
	3	250		7	20						

3.2.2 【Class 1】 Gain Adjustments

Pr1.00	Label	1 st position loop gain			Mode	PP		HM			
	Range	0~3000 0	Unit	0.1/s	Default	320	Index	2100h			
	Activation	Immediate									
<p>Higher position loop gain value improves the responsiveness of the servo driver and lessens the positioning time.</p> <p>Position loop gain value shouldn't exceed responsiveness of the mechanical system and take in consideration velocity loop gain, if not it might cause vibration, mechanical noise and overtravel. As velocity loop gain is based on position loop gain, please set both values accordingly.</p> <p>Recommended range: $1.2 \leq Pr1.00/Pr1.01 \leq 1.8$</p>											

Pr1.01	Label	1 st velocity loop gain			Mode						F
	Range	1~32767	Unit	0.1Hz	Default	180	Index	2101h			
	Activation	Immediate									
<p>To determine the responsiveness of the velocity loop. If inertia ratio of Pr0.04 is uniform with actual inertia ratio, velocity loop responsiveness = Pr1.01.</p> <p>To increase position loop gain and improve responsiveness of the whole system, velocity loop gain must be set at higher value. Please notice that if the velocity loop gain is too high, it might cause vibration.</p>											

Pr1.02	Label	1 st Integral Time Constant of Velocity Loop			Mode						F
	Range	1~10000	Unit	0.1ms	Default	310	Index	2102h			
	Activation	Immediate									
<p>If auto gain adjusting function is not enabled, Pr1.02 is activated.</p> <p>The lower the set value, the closer the lag error at stop to 0 but might cause vibration. If the value set is overly large, overshoot, delay of positioning time duration and lowered responsiveness might occur.</p> <p>Set 10000 to deactivate Pr1.02.</p> <p>Recommended range: $50000 \leq Pr1.01 \times Pr1.02 \leq 150000$</p> <p>For example: Velocity loop gain Pr1.01=500(0.1Hz), which is 50Hz. Integral time constant of velocity loop should be $100(0.1ms) \leq Pr1.02 \leq 300(0.1ms)$</p>											

Pr1.03	Label	1 st velocity detection filter			Mode						F																																																																				
	Range	0~10000	Unit	—	Default	15	Index			2103h																																																																					
	Activation	Immediate																																																																													
<p>This filter is a low pass filter. It blocks high frequencies which cause system instability from velocity feedback data. The higher the set value, lower frequencies will be blocked and velocity responsiveness will also be lowered. Pr1.03 needs to match velocity loop gain. Please refer to the following table.</p> <table border="1" style="width: 100%; border-collapse: collapse;"> <thead> <tr> <th style="background-color: #D9E1F2;">Set Value</th> <th style="background-color: #D9E1F2;">Velocity Detection Filter Cut-off Frequency(Hz)</th> <th style="background-color: #D9E1F2;">Set Value</th> <th style="background-color: #D9E1F2;">Velocity Detection Filter Cut-off Frequency(Hz)</th> </tr> </thead> <tbody> <tr><td>0</td><td>2500</td><td>16</td><td>750</td></tr> <tr><td>1</td><td>2250</td><td>17</td><td>700</td></tr> <tr><td>2</td><td>2100</td><td>18</td><td>650</td></tr> <tr><td>3</td><td>2000</td><td>19</td><td>600</td></tr> <tr><td>4</td><td>1800</td><td>20</td><td>550</td></tr> <tr><td>5</td><td>1600</td><td>21</td><td>500</td></tr> <tr><td>6</td><td>1500</td><td>22</td><td>450</td></tr> <tr><td>7</td><td>1400</td><td>23</td><td>400</td></tr> <tr><td>8</td><td>1300</td><td>24</td><td>350</td></tr> <tr><td>9</td><td>1200</td><td>25</td><td>300</td></tr> <tr><td>10</td><td>1100</td><td>26</td><td>250</td></tr> <tr><td>11</td><td>1000</td><td>27</td><td>200</td></tr> <tr><td>12</td><td>950</td><td>28</td><td>175</td></tr> <tr><td>13</td><td>900</td><td>29</td><td>150</td></tr> <tr><td>14</td><td>850</td><td>30</td><td>125</td></tr> <tr><td>15</td><td>800</td><td>31</td><td>100</td></tr> </tbody> </table>												Set Value	Velocity Detection Filter Cut-off Frequency(Hz)	Set Value	Velocity Detection Filter Cut-off Frequency(Hz)	0	2500	16	750	1	2250	17	700	2	2100	18	650	3	2000	19	600	4	1800	20	550	5	1600	21	500	6	1500	22	450	7	1400	23	400	8	1300	24	350	9	1200	25	300	10	1100	26	250	11	1000	27	200	12	950	28	175	13	900	29	150	14	850	30	125	15	800	31	100
Set Value	Velocity Detection Filter Cut-off Frequency(Hz)	Set Value	Velocity Detection Filter Cut-off Frequency(Hz)																																																																												
0	2500	16	750																																																																												
1	2250	17	700																																																																												
2	2100	18	650																																																																												
3	2000	19	600																																																																												
4	1800	20	550																																																																												
5	1600	21	500																																																																												
6	1500	22	450																																																																												
7	1400	23	400																																																																												
8	1300	24	350																																																																												
9	1200	25	300																																																																												
10	1100	26	250																																																																												
11	1000	27	200																																																																												
12	950	28	175																																																																												
13	900	29	150																																																																												
14	850	30	125																																																																												
15	800	31	100																																																																												

Pr1.04	Label	1 st Torque Filter Time Constant			Mode						F
	Range	0~2500	Unit	0.01ms	Default	126	Index			2104h	
	Activation	Immediate									
<p>To set torque command low-pass filter, add a filter delay time constant to torque command and filter out the high frequencies in the command. Often used to reduce or eliminate some noise or vibration during motor operation, but it will reduce the responsiveness of current loop, resulting in undermining velocity loop and position loop control. Pr1.04 needs to match velocity loop gain. Recommended range: $1,000,000 / (2\pi \times \text{Pr1.04}) \geq \text{Pr1.01} \times 4$</p> <p>For example: Velocity loop gain Pr1.01=180(0.1Hz) which is 18Hz. Time constant of torque filter should be $\text{Pr1.01} \leq 221(0.01\text{ms})$</p> <p>If mechanical vibration is due to servo driver, adjusting Pr1.04 might eliminate the vibration. The smaller the value, the better the responsiveness but also subjected to machine conditions. If the value is too large, it might lower the responsiveness of current loop.</p> <p>With higher Pr1.01 value settings and no resonance, reduce Pr1.04 value; With lower Pr1.01 value settings, increase Pr1.04 value to lower motor noise.</p>											

Pr1.05	Label	2 nd Position Loop Gain			Mode	PP			HM			
	Range	0~30000	Unit	0.1/s	Default	380	Index		2105h			
	Activation	Immediate										

Pr1.06	Label	2 nd velocity loop gain			Mode							F
	Range	1~32767	Unit	0.1Hz	Default	180	Index		2106h			
	Activation	Immediate										

Pr1.07	Label	2 nd Integral Time Constant of Velocity Loop			Mode							F
	Range	1~10000	Unit	0.1ms	Default	10000	Index		2107h			
	Activation	Immediate										

Pr1.08	Label	2 nd velocity detection filter			Mode							F
	Range	0~31	Unit	—	Default	15	Index		2108h			
	Activation	Immediate										

Pr1.09	Label	2 nd Torque Filter Time Constant			Mode							F
	Range	0~2500	Unit	0.01ms	Default	126	Index		2109h			
	Activation	Immediate										

Position loop, velocity loop, velocity detection filter, torque command filter each have 2 pairs of gain or time constant (1st and 2nd).

Pr1.10	Label	Velocity feed forward gain			Mode	PP			HM			
	Range	0~1000	Unit	0.10%	Default	300	Index		2110h			
	Activation	Immediate										

Used for decreasing following error caused by low responsiveness of velocity loop. Might cause overshoot or increase in noise if set value is too high.

Pr1.11	Label	Velocity feed forward filter time constant			Mode	PP			HM			
	Range	0~6400	Unit	0.01ms	Default	50	Index		2111h			
	Activation	Immediate										

Set velocity feed forward low pass filter to eliminate high or abnormal frequencies in velocity feed forward command. Often used when position command with low resolution or high electronic gear ratio to smoothen velocity feed forward.

Position deviation under constant velocity can be lowered with higher velocity feed forward gain. Please to refer to the equation below.

$$\text{Position deviation[Uint]} = \frac{\text{Set velocity}[\frac{\text{Uint}}{\text{s}}]}{\text{Position loop gain[Hz]}} \times \frac{100 - \text{Velocity feed forward gain}[\%]}{100}$$

Pr1.12	Label	Torque feed forward gain			Mode	PP	PV	HM				
	Range	0~1000	Unit	0.1%	Default	0		Index	2112h			
	Activation	Immediate										
Before using torque feed forward, please set correct inertia ratio. By increasing torque feed forward gain, position deviation on constant acceleration/deceleration can be reduced to close to 0. Under ideal condition and trapezoidal speed profile, position deviation of the whole motion can be reduced to close to 0. In reality, perturbation torque will always exist, hence position deviation can never be 0.												

Pr1.13	Label	Torque feed forward filter time constant			Mode	PP	PV	HM				
	Range	0~6400	Unit	0.01ms	Default	0		Index	2113h			
	Activation	Immediate										
Low pass filter to eliminate abnormal or high frequencies in torque feed forward command. Usually used when encoder has lower resolution or precision. Noise reduces if torque feed forward filter time constant is set higher but position deviation will increase at acceleration varied points.												

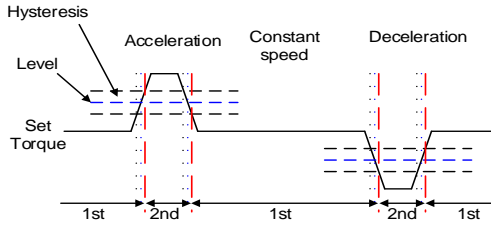
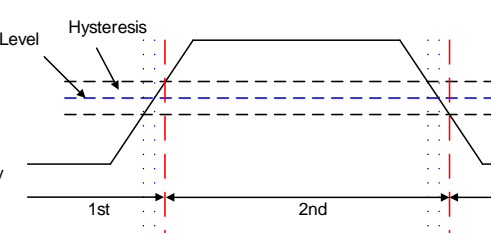
Pr1.15	Label	Position control gain switching mode			Mode						F
	Range	0~11	Unit	—	Default	0	Index				2115h
	Activation	Immediate									
Set Value	Condition	Gain switching condition									
0	1 st gain fixed	Fixed on using 1 st gain(Pr1.00-Pr1.04)									
1	2 nd gain fixed	Fixed on using 2 nd gain (Pr1.05-Pr1.09)									
2	Reserved										
3	High set torque	<p>Switch to 2nd gain when set torque command absolute value larger than (level + hysteresis)[%] Switch to 1st gain when set torque command absolute value smaller than (level - hysteresis)[%]</p> 									
4	Reserved	Reserved									
5	High set velocity	<p>Valid for position and velocity control. Switch to 2nd gain when set velocity command absolute value larger than (level + hysteresis)[r/min] Switch to 1st gain when set velocity command absolute value smaller than (level-hysteresis)[r/min]</p> 									

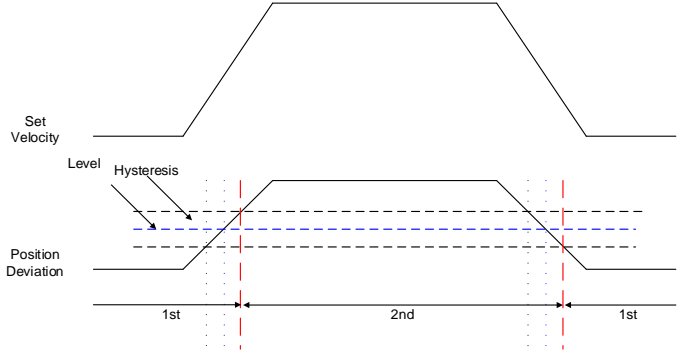
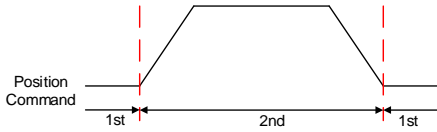
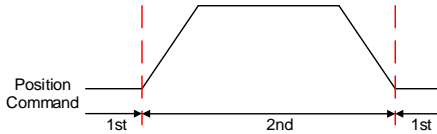
<p>6</p> <p>Large position deviation</p>		<p>Valid for position control. Switch to 2nd gain when position deviation absolute value larger than (level + hysteresis)[pulse] Switch to 1st gain when position deviation absolute value smaller than (level-hysteresis)[pulse]</p> 
<p>7</p> <p>Pending position command</p>		<p>Valid for position control. Switch to 2nd gain if position command $\neq 0$ Switch to 1st gain if position command remains = 0 throughout the duration of delay time.</p> 
<p>8</p> <p>Not yet in position</p>		<p>Valid for position control. Switch to 2nd gain if position command is not completed. Switch to 1st gain if position command remains uncompleted throughout the duration of delay time.</p> 
<p>9</p> <p>High actual velocity</p>		<p>Valid for position control. Switch to 2nd gain when actual velocity absolute value larger than (level + hysteresis)[r/min] Switch to 1st gain when actual velocity absolute value remains smaller throughout the duration of delay time than (level-hysteresis)[r/min]</p>

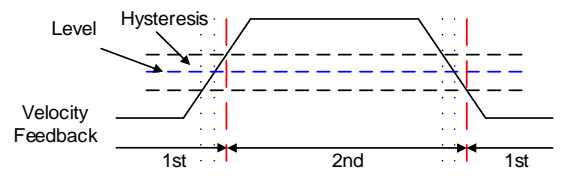
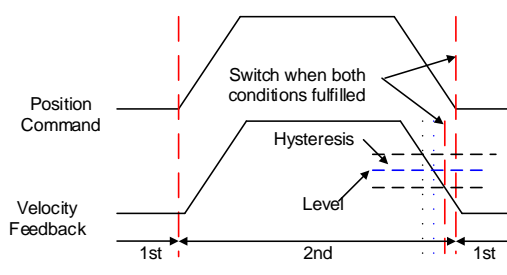
		
10	Pending position command + actual velocity	<p>Valid for position control. Switch to 2nd gain if position command $\neq 0$ Switch to 1st gain if positional command = 0 throughout the duration of delay time and absolute value of actual velocity remains smaller than (level - hysteresis) (r/min)</p> 

For position control mode, set Pr1.15=3,5,6,9,10;
 For velocity control mode, set Pr1.15=3,5,9;

**** Above 'level' and 'hysteresis' are in correspondence to Pr1.17 Position control gain switching level and Pr1.18 Hysteresis at position control switching.**

Pr1.17	Label	Position control gain switching level			Mode						F										
	Range	0~20000	Unit	Mode dependent	Default	50	Index			2117h											
	Activation	Immediate																			
	Set threshold value for gain switching to occur. Unit is mode dependent.																				
			<table border="1" style="width: 100%;"> <thead> <tr> <th style="text-align: left;">Switching condition</th> <th style="text-align: left;">Unit</th> </tr> </thead> <tbody> <tr> <td>Position</td> <td>Encoder pulse count</td> </tr> <tr> <td>Velocity</td> <td>RPM</td> </tr> <tr> <td>Torque</td> <td>%</td> </tr> </tbody> </table>		Switching condition	Unit	Position	Encoder pulse count	Velocity	RPM	Torque	%									
Switching condition	Unit																				
Position	Encoder pulse count																				
Velocity	RPM																				
Torque	%																				
Please set level \geq hysteresis																					

Pr1.18	Label	Hysteresis at position control switching			Mode							F
	Range	0~20000	Unit	Mode dependent	Default	33	Index			2118h		
	Activation	Immediate										
To eliminate the instability of gain switching. Used in combination with Pr1.17 using the same unit. If level < hysteresis, drive will set internally hysteresis = level.												

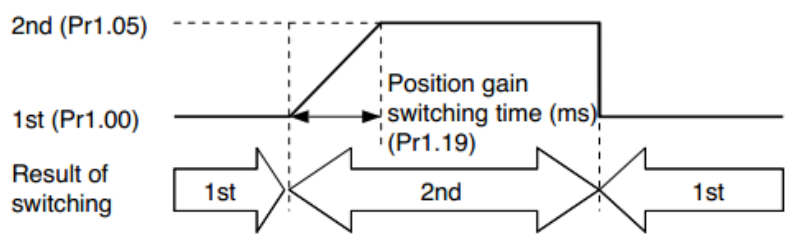
Pr1.19	Label	Position gain switching time			Mode							F
	Range	0~10000	Unit	0.1ms	Default	33	Index			2119h		
	Activation	Immediate										
During position control, to ease torque changes and vibration due to rapid changes in position loop gain, set suitable Pr1.19 value For example: 1st (pr1.00) <-> 2nd (Pr1.05)												
												

3.2.3 【Class 2】 Vibration Suppression

Pr2.00	Label	Adaptive filtering mode settings			Mode							F															
	Range	0~4	Unit	-	Default	0	Index			2200h																	
	Activation	Immediate																									
<table border="1" style="width: 100%; border-collapse: collapse;"> <thead> <tr> <th style="width: 15%;">Set value</th> <th colspan="2">Explanation</th> </tr> </thead> <tbody> <tr> <td style="text-align: center;">0</td> <td>Adaptive filter: invalid</td> <td>Parameters related to 3rd and 4th notch filter remain unchanged</td> </tr> <tr> <td style="text-align: center;">1</td> <td>Adaptive filter: 1 filter valid for once.</td> <td>1 adaptive filter becomes valid. 3rd notch filter related parameters updated accordingly. Pr2.00 switches automatically to 0 once updated.</td> </tr> <tr> <td style="text-align: center;">2</td> <td>Adaptive filter: 1 filter remains valid</td> <td>1 adaptive filter becomes valid. 3rd notch filter related parameters will keep updating accordingly.</td> </tr> <tr> <td style="text-align: center;">3-4</td> <td>Reserved</td> <td>-</td> </tr> </tbody> </table>													Set value	Explanation		0	Adaptive filter: invalid	Parameters related to 3 rd and 4 th notch filter remain unchanged	1	Adaptive filter: 1 filter valid for once.	1 adaptive filter becomes valid. 3 rd notch filter related parameters updated accordingly. Pr2.00 switches automatically to 0 once updated.	2	Adaptive filter: 1 filter remains valid	1 adaptive filter becomes valid. 3 rd notch filter related parameters will keep updating accordingly.	3-4	Reserved	-
Set value	Explanation																										
0	Adaptive filter: invalid	Parameters related to 3 rd and 4 th notch filter remain unchanged																									
1	Adaptive filter: 1 filter valid for once.	1 adaptive filter becomes valid. 3 rd notch filter related parameters updated accordingly. Pr2.00 switches automatically to 0 once updated.																									
2	Adaptive filter: 1 filter remains valid	1 adaptive filter becomes valid. 3 rd notch filter related parameters will keep updating accordingly.																									
3-4	Reserved	-																									

Pr2.01	Label	1 st notch frequency			Mode							F
	Range	50~4000	Unit	Hz	Default	4000	Index	2201h				
	Activation	Immediate										
Set center frequency of 1 st torque command notch filter. Set Pr2.01 to 4000 to deactivate notch filter												

Pr2.02	Label	1 st notch bandwidth selection			Mode							F
	Range	0~20	Unit	-	Default	4	Index	2202h				
	Activation	Immediate										
Set notch bandwidth for 1 st resonant notch filter. Under normal circumstances, please use factory default settings. If resonance is under control, in combination with Pr2.01 and Pr2.03, Pr2.02 can be reduced to improve current loop responsiveness which allows higher mechanical stiffness settings.												

Pr2.03	Label	1 st notch depth selection			Mode							F
	Range	0~99	Unit	-	Default	0	Index	2203h				
	Activation	Immediate										
Set notch depth for 1 st resonant notch filter. Under normal circumstances, please use factory default settings. If resonance is under control, in combination with Pr2.01 and Pr2.02, Pr2.03 can be reduced to improve current loop responsiveness which allows higher mechanical stiffness settings.												

Pr2.04	Label	2 nd notch frequency			Mode							F
	Range	50~4000	Unit	Hz	Default	4000	Index	2204h				
	Activation	Immediate										
Set center frequency of 2 nd torque command notch filter. Set Pr2.04 to 4000 to deactivate notch filter												

Pr2.05	Label	2 nd notch bandwidth selection			Mode							F
	Range	0~20	Unit	-	Default	4	Index	2205h				
	Activation	Immediate										
Set notch bandwidth for 2 nd resonant notch filter. Under normal circumstances, please use factory default settings. If resonance is under control, in combination with Pr2.04 and Pr2.06, Pr2.05 can be reduced to improve current loop responsiveness which allows higher mechanical stiffness settings.												

Pr2.06	Label	2 nd notch depth selection			Mode						F
	Range	0~99	Unit	-	Default	0	Index	2206h			
	Activation	Immediate									
Set notch depth for 1 st resonant notch filter. When Pr2.06 value is higher, notch depth becomes shallow, phase lag reduces. Under normal circumstances, please use factory default settings. If resonance is under control, in combination with Pr2.04 and Pr2.05, Pr2.06 can be reduced to improve current loop responsiveness which allows higher mechanical stiffness settings.											

Pr2.07	Label	3 rd notch frequency			Mode						F
	Range	50~4000	Unit	Hz	Default	4000	Index	2207h			
	Activation	Immediate									
Set center frequency of 3 rd torque command notch filter. Set Pr2.07 to 4000 to deactivate notch filter											

Pr2.08	Label	3 rd notch bandwidth selection			Mode						F
	Range	0~20	Unit	-	Default	4	Index	2287h			
	Activation	Immediate									
Set notch bandwidth for 3 rd resonant notch filter. Under normal circumstances, please use factory default settings.											

Pr2.09	Label	3 rd notch depth selection			Mode						F
	Range	0~99	Unit	-	Default	0	Index	2206h			
	Activation	Immediate									
Set notch depth for 1 st resonant notch filter. When Pr2.09 value is higher, notch depth becomes shallow, phase lag reduces.											

Pr2.14	Label	1 st damping frequency			Mode						F
	Range	0~2000	Unit	0.1Hz	Default	0	Index	2214h			
	Activation	Immediate									
0: Deactivate To suppress wobble at load end. Often used when wobble of flexible structure due to high deceleration upon stopping. Especially effective for wobble with frequencies under 100Hz. Set Pr2.15 to wobble frequency (wobble frequency can be determined using tracing function of Motion Studio)											

Pr2.22	Label	Position command smoothing filter			Mode	PP		HM		
	Range	0~32767	Unit	0.1ms	Default	0	Index	2222h		
	Activation	Stop axis								

To set time constant of 1 time delay filter of position command.
 To set time constant of 1 time delay filter, according to target velocity V_c square wave command as show below.

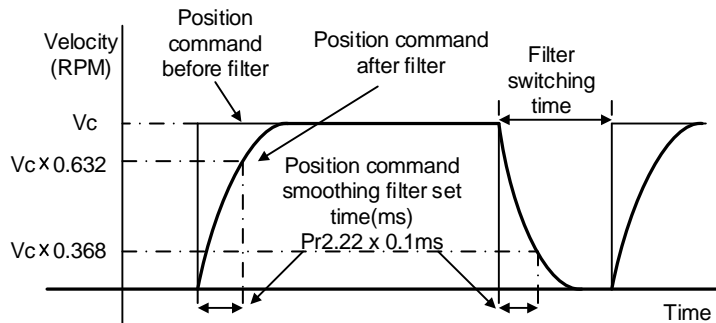

Usually applied when there is rather sharp acceleration which might cause motor overshoot or undershoot. To smoothen command signal, reduces impact to machines and eliminate vibration. If Pr2.22 is set too high, overall time will be lengthened.

Pr2.23	Label	Position command FIR filter		Mode	PP		HM			
	Range	0~10000	Unit	0.1ms	Default	0	Index	2223h		
	Activation	Disable axis								

As shown below, when target velocity V_c square wave command reaches V_c , it becomes trapezoidal wave after filtering.

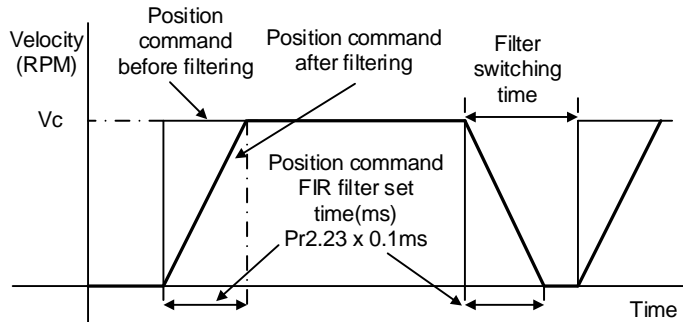

As shown below, when target velocity V_c trapezoidal command reaches V_c , it becomes S wave after filtering.

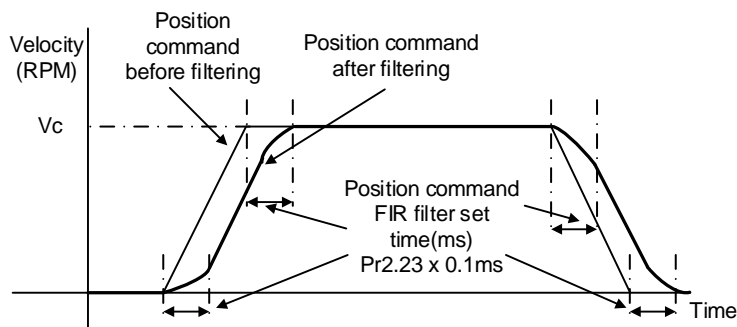

Usually applied when there is rather sharp acceleration which might cause motor overshoot or undershoot. To smoothen command signal, reduces impact to machines and eliminate vibration. If Pr2.23 is set too high, overall time will be lengthened.

****Please wait for command to stop and after filter idle time to modify Pr2.23.**

Filter switching time = (Pr2.23 set value x 0.1ms + 0.25ms)

3.2.4 【Class 3】 Velocity/ Torque Control

Pr3.00	Label	Internal/External settings of velocity settings			Mode							F
	Range	0~3	Unit	-	Default	1	Index	2300h				
	Activation	Immediate										
Internal velocity settings can be achieved by connecting to driver's input interface.												
		Set value	Velocity settings									
		0	Analog velocity command (SPR)									
		[1]	Internal velocity command: 1 st to 4 th speed (Pr3.04 to Pr3.07)									
		2	Internal velocity command 1 st to 3 rd speed (Pr3.04 to Pr3.06), Analog velocity command (SPR)									
		3	Internal velocity command 1 st to 8 th speed (Pr3.00 to Pr3.11)									

Pr3.03	Label	Velocity command input inversion			Mode							F
	Range	0~1	Unit	-	Default	0	Index	2303h				
	Activation	Immediate										
Specify the polarity of the voltage applied to the analog velocity command (SPR).												
		Set value	Motor rotational direction									
		0	Non-reversal	"+Voltage" → "Positive direction" "-Voltage" → "Negative direction"								
		1	Reversal	"+Voltage" → "Negative direction" "-Voltage" → "Positive direction"								
While servo driver is set on simulated velocity control and in combination with external positioning device, motor might undergo abnormal behavior when velocity command signal polarity from external positioning device doesn't match the polarity set in Pr3.03												

Pr3.04	Label	1 st speed of velocity setting			Mode							F
	Range	-10000~10000	Unit	r/min	Default	0	Index	2304h				
	Activation	Immediate										
Pr3.05	Label	2 nd speed of velocity setting			Mode							F
	Range	-10000~10000	Unit	r/min	Default	0	Index	2305h				
	Activation	Immediate										
Pr3.06	Label	3 rd speed of velocity setting			Mode							F
	Range	-10000~10000	Unit	r/min	Default	0	Index	2306h				
	Activation	Immediate										
Pr3.07	Label	4 th speed of velocity setting			Mode							F
	Range	-10000~10000	Unit	r/min	Default	0	Index	2307h				
	Activation	Immediate										

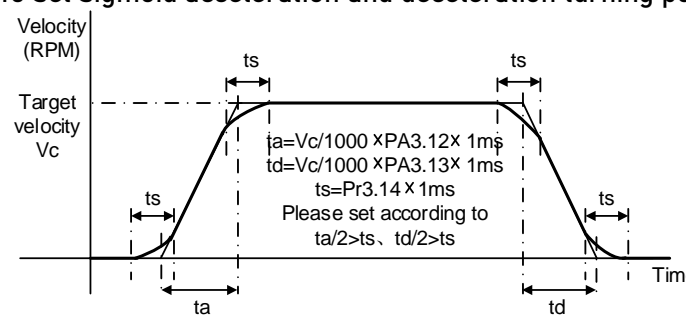
Pr3.14	Label	Sigmoid acceleration/deceleration settings			Mode		PV				
	Range	0~1000	Unit	ms	Default	0	Index	2314h			
	Activation	Axis disable									
To set sigmoid acceleration and deceleration turning point in accordance to Pr3.12 and Pr3.13.											
											

Pr3.16	Label	Zero speed clamp level			Mode		PV				
	Range	10~2000	Unit	RPM	Default	30	Index	2316h			
	Activation	Immediate									
Velocity command is forced to 0 when actual velocity is lower than Pr3.16 and after static time set in Pr3.23											

Pr3.24	Label	Maximum motor rotational velocity			Mode						F
	Range	0~10000	Unit	r/min	Default	0	Index	2324h			
	Activation	Immediate									
Maximum motor rotational as accordance to technical specification if set to 0											

3.2.5 【Class 4】 I/O Interface Setting

Pr4.00	Label	Input selection DI1			Mode						F
	Range	0x0~0xFF	Unit	—	Default	0x0	Index	2400h			
	Activation	Immediate									
Pr4.01	Label	Input selection DI2			Mode						F
	Range	0x0~0xFF	Unit	—	Default	0x1	Index	2401h			
	Activation	Immediate									
Pr4.02	Label	Input selection DI3			Mode						F
	Range	0x0~0xFF	Unit	—	Default	0x2	Index	2402h			
	Activation	Immediate									

Pr4.03	Label	Input selection DI4			Mode						F
	Range	0x0~0xFF	Unit	—	Default	0x16	Index		2403h		
	Activation	Immediate									

Digital input DI allocation using hexadecimal system

Input	Symbol	Set value		0x60FD(bit)
		Normally open	Normally close	
Invalid	—	0h	-	×
Positive limit switch	POT	1h	81h	Bit1
Negative limit switch	NOT	2h	82h	Bit0
Clear alarm	A-CLR	4h	-	×
Forced alarm	E-STOP	14h	94h	×
Home switch	HOME-SWITCH	16h	96h	Bit2

- Please don't set anything other than listed in table above.
- Normally open: Valid when input = ON Normally close: Valid when input = OFF
- Er210 might occur if same function is allocated to different channels at the same time
- Channel that has no value doesn't affect driver motion.
- Front panel is of hexadecimal system.
- Pr4.00 – Pr4.03 corresponds to DI1 – DI4. External sensors can be connected if the parameters are all set to 0. Controller will read 60FD bit4 – 7 to get DI1 – DI4 actual status.

Pr4.10	Label	Output selection D01			Mode						F
	Range	0x0~0xFF	Unit	—	Default	0x1	Index		2410h		
	Activation	Immediate									
Pr4.11	Label	Output selection D02			Mode						F
	Range	0x0~0xFF	Unit	—	Default	0x3	Index		2411h		
	Activation	Immediate									
Pr4.12	Label	Output selection D03			Mode						F
	Range	0x0~0xFF	Unit	—	Default	0x4	Index		2412h		
	Activation	Immediate									

Digital output D0 allocation using hexadecimal system.

Output	Symbol	Set value	
		Normally open	Normally close
Master device control	—	00h	-
Alarm	ALM	01h	81h
Servo-Ready	S-RDY	02h	82h
External brake released	BRK-OFF	03h	83h
Positioning completed	INP	04h	84h
At-speed	AT-SPEED	05h	85h
Torque limit signal	TLC	06h	86h
Zero speed clamp detection	ZSP	07h	87h

Velocity coincidence	V-COIN	08h	88h
Servo status	SRV-ST	12h	92h
Position command ON/OFF	P-CMD	0Bh	8Bh
Velocity limit signal	V-LIMIT	0Dh	8Dh
Velocity command ON/OFF	V-CMD	0Fh	8Fh
Homing done	HOME-OK	22h	A2h

- Please don't set any other than the outputs listed in the table above.
- Normally open: Active low
- Normally close: Active high
- Front panel is of hexadecimal system.
- Pr4.10 - Pr4.12 corresponds to D01 - D03. If all parameters are set to 0, master device controls the outputs, object dictionary 0x60FE sub-index 01 bit16-18 corresponds to D01-D03.

Pr4.31	Label	Positioning complete		Mode	PP		HM		
	Range	0~10000	Unit	Command unit	Default	20	Index	2431h	
	Activation	Immediate							

To set position deviation range of INP1 positioning completed output signal.

Pr4.32	Label	Positioning complete		Mode	PP		HM		
	Range	0~4	Unit	-	Default	1	Index	2432h	
	Activation	Immediate							

Output conditions of INP1 positioning completed output signal

Set value	Positioning completed signal
0	Signal valid when the position deviation is smaller than Pr4.31
1	Signal valid when there is no position command and position deviation is smaller than Pr4.31
2	Signal valid when there is no position command, zero-speed clamp detection (ZSP) signal is ON and the positional deviation is smaller than Pr4.31
3	Signal valid when there is no position command and position deviation is smaller than Pr4.31. Signal ON when within the time set in Pr4.33 otherwise OFF.
4	When there is no command, position detection starts after the delay time set in Pr4.33. Signal valid when there is no position command and positional deviation is smaller than Pr4.31.

Pr4.33	Label	INP positioning delay time			Mode	PP		HM			
	Range	0~15000	Unit	1ms	Default	0	Index	2433h			
	Activation	Immediate									

To set delay time when Pr 4.32 = 3

Set value	Positioning completed signal
0	Indefinite delay time, signal ON until next position command
1-15000	OFF within the time set; ON after time set. Switch OFF after receiving next position command.

Pr4.34	Label	Zero speed			Mode					F
	Range	1~2000	Unit	RPM	Default	50	Index	2434h		
	Activation	Immediate								

To set threshold value for zero speed clamp detection.

Zero speed clamp detection (ZSP) output signal valid when motor speed goes under the value set in Pr4.34

- Disregard the direction of rotation, valid for both directions.
- Hysteresis of 10RPM. Please refer to diagram on the right side.

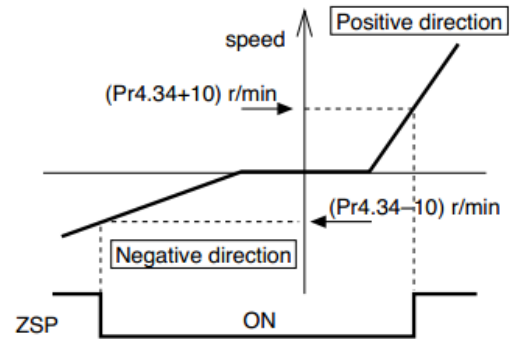

Pr4.35	Label	Velocity coincidence		Mode	PV				
	Range	10~2000	Unit	RPM	Default	50	Index	2435h	
	Activation	Immediate							

If the difference between velocity command and motor actual speed is below Pr4.35, Velocity coincidence (V-COIN) output signal valid.

Due to 10RPM hysteresis:

Velocity coincidence output OFF → ON timing (Pr4.35 -10) r/min

Velocity coincidence output ON → OFF timing (Pr4.35 +10) r/min

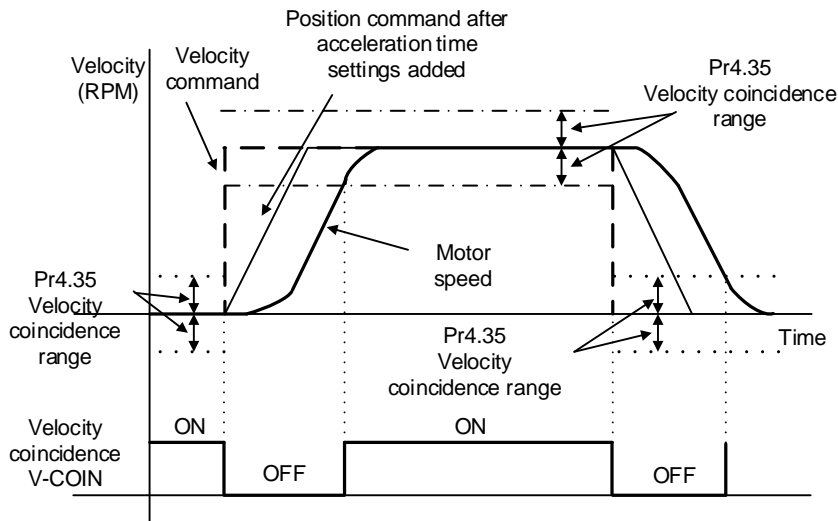

Pr4.36	Label	Reached velocity		Mode	PV				
	Range	10~2000	Unit	RPM	Default	1000	Index	2436h	
	Activation	Immediate							

When motor velocity > Pr4.36, AT-speed output signal is valid.
Detection using 10RPM hysteresis.

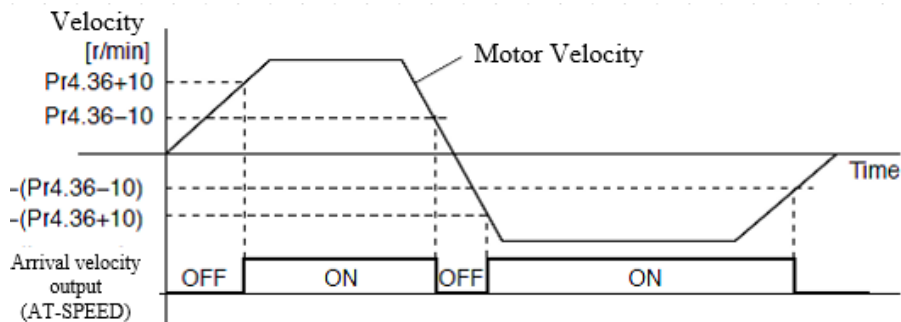

Pr4.37	Label	Motor power-off delay time			Mode						F
	Range	0~3000	Unit	1ms	Default	100	Index	2437h			
	Activation	Immediate									

To set delay time for holding brake to be activated after motor power off to prevent axis from sliding.

Pr4.38	Label	Delay time for holding brake release			Mode						F
	Range	0~3000	Unit	1ms	Default	0	Index	2438h			
	Activation	Immediate									

To set delay time for holding brake to be released after motor power on. Motor will remain at current position and input command is masked to allow holding brake to be fully released before motor is set in motion.

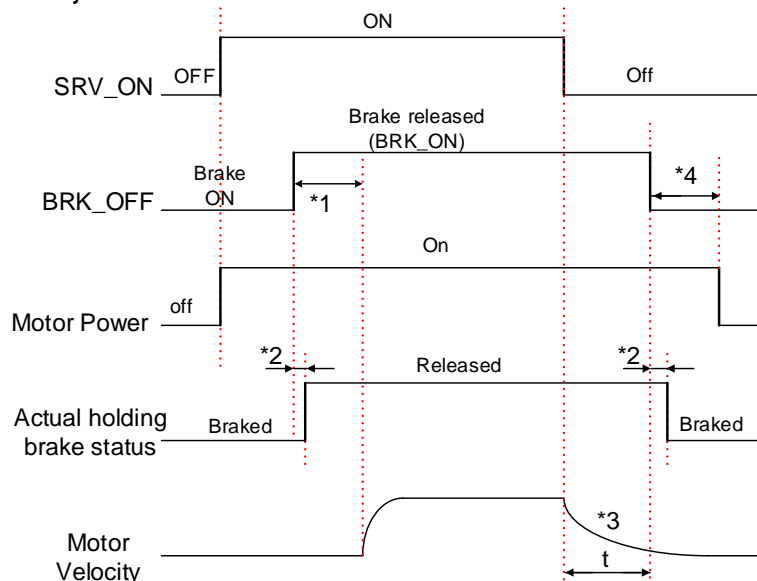

*1: Delay time set in Pr4.38

*2: Delay time from the moment BRK_OFF signal is given until actual holding brake is released or BRK_ON signal is given until actual holding brake is activated. It is dependent on the holding brake of the motor.

*3: Deceleration time is determined by Pr6.14 or if motor speed goes below Pr4.39, whichever comes first. BRK_OFF given after deceleration time.

*4: Pr4.37 set time value.

Delay time from the moment SRV_ON is given until BRK_OFF switch to BRK_ON, is less than 500ms.

Pr4.39	Label	Holding brake activation speed			Mode							F
	Range	30~3000	Unit	RPM	Default	30	Index	2439h				
	Activation	Immediate										

To set the activation speed for which holding brake will be activated.

When SRV-OFF signal is given, motor decelerates, after it reaches below Pr4.39 and Pr6.14 is not yet reached, BRK_OFF is given.

BRK_OFF signal is determined by Pr6.14 or if motor speed goes below Pr4.39, whichever comes first.

Application:

1. After disabling axis, Pr6.14 has been reached but motor speed is still above Pr4.39, BRK_OFF signal given.
2. After disabling axis, Pr6.14 has not been reached but motor speed is below Pr4.39, BRK_OFF signal given.

Pr4.43	Label	Emergency stop function			Mode							F
	Range	0~1	Unit	-	Default	0	Index	2443h				
	Activation	Immediate										

0: Emergency stop is valid, servo driver will be forced to STOP and alarm occurs.

1: Emergency stop is invalid, servo driver will not be forced to STOP.

3.2.6 【Class 5】 Extension settings

Pr5.04	Label	Driver prohibition input settings			Mode							F
	Range	0~2	Unit	—	Default	0	Index	2504h				
	Activation	Immediate										

To set driver prohibition input (POT/NOT): If set to 1, no effect on homing mode.

Set value	Explanation
0	POT → Positive direction drive prohibited NOT → Negative direction drive prohibited
1	POT and NOT invalid
2	Any single sided input from POT or NOT might cause Er260

In homing mode, POT/NOT invalid, please set object dictionary 5012-04 bit0=1

Pr5.06	Label	Servo-off mode			Mode							F
	Range	0~5	Unit	—	Default	0	Index	2506h				
	Activation	After restart										

To set torque limit for servo braking mode.
 If Pr5.11 = 0, use torque limit as under normal situation.
 Between max. torque 6072 and Pr5.11, actual torque limit will take smaller value.

Pr5.12	Label	Overload setting level			Mode						F
	Range	0~115	Unit	%	Default	0	Index	2512h			
	Activation	Immediate									
If Pr5.12 = 0, overload level = 115% Use only when overload level degradation is needed.											

Pr5.13	Label	Overspeed level settings			Mode						F
	Range	0~10000	Unit	RPM	Default	0	Index	2513h			
	Activation	Immediate									
If motor speed exceeds Pr5.13, Er1A0 might occur. When Pr5.13 = 0, overspeed level = max. motor speed x 1.2											

Pr5.15	Label	I/O digital filter			Mode						F
	Range	0~255	Unit	0.1ms	Default	10	Index	2515h			
	Activation	Immediate									
Digital filtering of I/O input. Overly large value set will cause control delay.											

Pr5.20	Label	Position unit settings			Mode	PP		HM											
	Range	0~2	Unit	—	Default	2	Index	2520h											
	Activation	Disable																	
<table border="1" style="width: 100%; border-collapse: collapse;"> <thead> <tr> <th style="width: 50%;">Set value</th> <th style="width: 50%;">Unit</th> </tr> </thead> <tbody> <tr> <td style="text-align: center;">0</td> <td style="text-align: center;">Encoder unit</td> </tr> <tr> <td style="text-align: center;">1</td> <td style="text-align: center;">Command unit</td> </tr> <tr> <td style="text-align: center;">2</td> <td style="text-align: center;">0.0001rev</td> </tr> </tbody> </table> <p>Command unit: Pulse from host Encoder unit: Pulse from encoder Pr5.20 only changes the unit use on host tracing function, has no relation with any position related parameters.</p>												Set value	Unit	0	Encoder unit	1	Command unit	2	0.0001rev
Set value	Unit																		
0	Encoder unit																		
1	Command unit																		
2	0.0001rev																		

Pr5.21	Label	Torque limit selection			Mode	PP		HM															
	Range	0~2	Unit	—	Default	2	Index	2521h															
	Activation	Immediate																					
<table border="1" style="margin: auto;"> <thead> <tr> <th style="background-color: #D9E1F2;">Set value</th> <th style="background-color: #D9E1F2;">Positive limit value</th> <th style="background-color: #D9E1F2;">Negative limit value</th> </tr> </thead> <tbody> <tr> <td>0</td> <td>Pr0.13</td> <td>Pr0.13</td> </tr> <tr> <td>1</td> <td>Pr0.13</td> <td>Pr5.22</td> </tr> <tr> <td>2</td> <td>60E0</td> <td>60E1</td> </tr> </tbody> </table> <p>Between max. torque 6072 and Pr5.21, actual torque limit will take smaller value.</p>												Set value	Positive limit value	Negative limit value	0	Pr0.13	Pr0.13	1	Pr0.13	Pr5.22	2	60E0	60E1
Set value	Positive limit value	Negative limit value																					
0	Pr0.13	Pr0.13																					
1	Pr0.13	Pr5.22																					
2	60E0	60E1																					

Pr5.22	Label	2 nd torque limit			Mode						F
	Range	0~500	Unit	%	Default	300	Index	2522h			
	Activation	Immediate									
<p>Limited by motor max. torque. Between max. torque 6072 and Pr5.22, actual torque limit will take smaller value.</p>											

Pr5.23	Label	Positive torque warning threshold			Mode						F
	Range	0~300	Unit	%	Default	0	Index	2523h			
	Activation	Immediate									
<p>If Pr5.23 = 0, threshold value = 95% If torque larger than rated torque, then output = Torque command limit</p>											

Pr5.24	Label	Negative torque warning threshold			Mode						F
	Range	0~300	Unit	%	Default	0	Index	2524h			
	Activation	Immediate									
<p>If Pr5.24 = 0, threshold value = 95% If torque smaller than rated torque, then output = Torque command limit</p>											

Pr5.37	Label	Torque warning threshold alarm delay time			Mode						F
	Range	0~5000	Unit	ms	Default	500	Index	2537h			
	Activation	Immediate									
<p>To set time threshold for output torque to reach limit under torque initialization mode. Only applicable for torque initialization method -6 to -1 Under torque initialization mode, motor torque reached Pr5.39 and the duration reaches Pr5.37 before moving into next step.</p>											

3.2.7 【Class 6】 Other settings

Pr6.04	Label	JOG trial run velocity command			Mode							F
	Range	0~10000	Unit	r/min	Default	400	Index			2604h		
	Activation	Immediate										
To set velocity for JOG trial run command.												

Pr6.05	Label	Position 3 rd gain valid time			Mode	PP			HM			
	Range	0~10000	Unit	0.1ms	Default	0	Index			2605h		
	Activation	Immediate										

To set time for 3rd gain to be valid
When not in use, set Pr6.05=0, Pr6.06=100

Pr6.06	Label	Position 3 rd gain scale factor			Mode	PP			HM			
	Range	0~1000	Unit	100%	Default	100	Index			2606h		
	Activation	Immediate										

Set up the 3rd gain by multiplying factor of the 1st gain

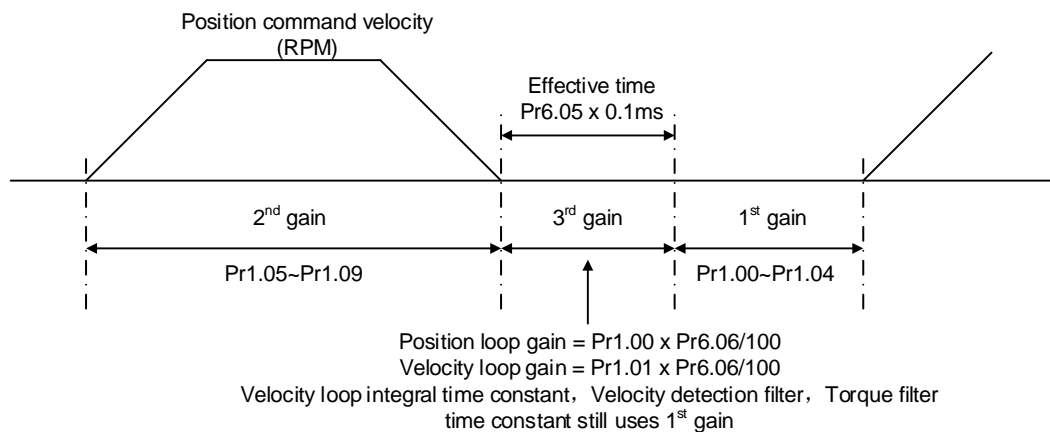

$$3^{rd} \text{ gain} = 1^{st} \text{ gain} \times Pr6.06/100$$

Only effective under position control mode, set $Pr6.05 \neq 0$, 3rd gain function activated, set 3rd gain value in Pr6.06. When 2nd gain switches to 1st gain, will go through 3rd, switching time value set in Pr1.19.

Above diagram is illustrated using $Pr1.15 = 7$.

Pr6.07	Label	Torque command additional value			Mode							F
	Range	-100~100	Unit	%	Default	0	Index			2607h		
	Activation	Immediate										
To set torque forward feed additional value of vertical axis. Applicable for loaded vertical axis, compensate constant torque. Application: When load move along vertical axis, pick any point from the whole motion and stop the load at that particular point with motor enabled but not rotating. Record output torque value from d04, use that value as torque command additional value (compensation value)												
Pr6.08	Label	Positive direction torque compensation value			Mode							F
	Range	-100~100	Unit	%	Default	0	Index			2608h		
	Activation	Immediate										
Pr6.09	Label	Negative direction torque compensation value			Mode							F
	Range	-100~100	Unit	%	Default	0	Index			2609h		
	Activation	Immediate										
To reduce the effect of mechanical friction in the movement(s) of the axis. Compensation values can be set according to needs for both rotational directions. Applications: 1. When motor is at constant speed, d04 will deliver torque values. Torque value in positive direction = T1; Torque value in negative direction = T2 $\text{Pr6.08/Pr6.09} = T_f = \frac{ T1 - T2 }{2}$												

Pr6.11	Label	Current response settings			Mode							F
	Range	50~100	Unit	%	Default	100	Index			2611h		
	Activation	Immediate										
To set driver current loop related effective value ratio												

Pr6.14	Label	Max. time to stop after disabling			Mode							F
	Range	0~3000	Unit	ms	Default	500	Index			2614h		
	Activation	Immediate										
To set the max. time allowed for the axis to stop on emergency stop or normal axis disabling. After disabling axis, if motor speed is still higher than Pr4.39 but the time set in Pr6.14 is reached, BRK_ON given and holding brake activated.												

BRK_ON given time is determined by Pr6.14 or when motor speed goes below Pr4.39, whichever comes first.

Applications:

1. After disabling axis, if motor speed is still higher than Pr4.39 but the time set in Pr6.14 is reached, BRK_ON given and holding brake activated.
2. After disabling axis, if motor speed is already lower than Pr4.39 but the time set in Pr6.14 is not yet reached, BRK_ON given and holding brake activated.

Pr6.20	Label	Trial run distance			Mode							F
	Range	0~1200	Unit	0.1rev	Default	10	Index	2620h				
	Activation	Immediate										
JOG (Position control) : Distance travel of each motion												

Pr6.21	Label	Trial run waiting time			Mode							F
	Range	0~30000	Unit	ms	Default	300	Index	2621h				
	Activation	Immediate										
JOG (Position control) : Waiting time after each motion												

Pr6.22	Label	No. of trial run cycles			Mode							F
	Range	0~32767	Unit	PCS	Default	5	Index	2622h				
	Activation	Immediate										
JOG (Position control) : No. of cycles												

Pr6.25	Label	Trial run acceleration			Mode							F
	Range	0~10000	Unit	ms/(1000rpm)	Default	200	Index	2625h				
	Activation	Immediate										
To set the acceleration/deceleration time for JOG command between 0 rpm to 1000 rpm												

Pr6.26	Label	Trial run mode			Mode							F
	Range	0~1	Unit	0	Default	1	Index	2626h				
	Activation	Immediate										
To set trial run mode												

Pr6.57	Label	Blocked rotor alarm delay time			Mode							F
	Range	0~1000	Unit	ms	Default	400	Index	2657h				
	Activation	Immediate										

To set delay time for blocked rotor alarm to trigger										
Pr6.58	Label	Homing position (16-bit high)			Mode					F
	Range	-2147483647~ 2147483647	Unit	-	Default	0	Index	2658h		
	Activation	Immediate								
Homing position 16-bit high										

Pr6.59	Label	Homing position (16-bit low)			Mode					F
	Range	-2147483647~ 2147483647	Unit	-	Default	0	Index	2659h		
	Activation	Immediate								
Homing position 16-bit low										

Pr6.61	Label	Z signal holding time			Mode					F
	Range	0~100	Unit	ms	Default	10	Index	2661h		
	Activation	Immediate								
To set the holding time for Z signal to maintain active high Application: 1. Z signal for 60FDH; 2. Z signal for homing process 3. Z-phase frequency output pulse width. Unit = 0.1ms; Please set $Pr6.61 \geq 0.2ms$ if used for 3 applications as above										

Pr6.62	Label	Overload threshold			Mode					F
	Range	0~99	Unit	%	Default	0	Index	2662h		
	Activation	Immediate								
To set overload alarm threshold										

Pr6.63	Label	Absolute multiturn data upper limit			Mode					F
	Range	0~32766	Unit	rev	Default	0	Index	2663h		
	Activation	After restart								
To set upper limit of multiturn data with absolute encoder set as rotational mode. When $Pr0.15 = 2$, feedback position = $0 \sim (Pr6.63+1) * \text{Encoder resolution}$										

3.3 402 Parameters Function

- Panel Display as follows:

PRO.00

classify and code  number

- Parameter Valid mode Description
 HM: Valid in homing mode
 PP: Valid in profile position mode
 PV: Valid in profile velocity mode
 PT: Valid in profile torque mode
 F: Valid in all modes

Index 603Fh	Label	Error code			Unit	-	Structure	VAR	Type	Uint 16
	Access	RO	Mapping	TPDO	Mode	F	Range	0x0~0 xFFFF	Default	0X0

Please refer to Chapter 9 for more details on error codes.

Index 6040h	Label	Control word			Unit	-	Structure	VAR	Type	Uint 16
	Access	RW	Mapping	RPDO	Mode	F	Range	0x0~ 0xFFFF F	Default	0X0

Bit	Label	Description
0	Start	1 - valid, 0 - invalid
1	Main circuit power on	1 - valid, 0 - invalid
2	Quick stop	0 - valid, 1 - invalid
3	Servo running	1 - valid, 0 - invalid
4-6	Running mode related	Related to each servo running mode
7	Fault reset	Reset resettable fault alarm. Rising edge of Bit7 is valid, bit7 remains at 1, and all other instructions are invalid
8	Pause	For more information on how to pause in each mode, refer to Object Dictionary 605Dh
9	No definition	Undefined
10	Reserved	Undefined
11-15	Reserved	Undefined

Index 6041h	Label	Status word			Unit	-	Structure	VAR	Type	Uint 16
	Access	RO	Mapping	TPDO	Mode	ALL	Range	0x0~ 0xFF FF	Default	0x0

Bit	Label	Description
0	Servo ready	1 - valid, 0 - invalid
1	Start	1 - valid, 0 - invalid
2	Servo running	1 - valid, 0 - invalid
3	Fault	1 - valid, 0 - invalid
4	Main circuit power on	1 - valid, 0 - invalid
5	Quick stop	0- valid, 1 - invalid
6	Servo cannot run	1 - valid, 0 - invalid
7	Warning	1 - valid, 0 - invalid
8	Reserved	Reserved
9	Remote control	1 - valid, 0 - invalid
10	Arrived at position	1 - valid, 0 - invalid
11	Internal limit valid	1 - valid, 0 - invalid
12-13	Mode related	Related to each servo operation mode
14	Reserved	Reserved
15	Origin found	1 - valid, 0 - invalid

Index 605Ah	Label	Quick stop option code			Unit	-	Structure	VAR	Type	INT 16
	Access	RW	Mapping	-	Mode	ALL	Range	0~7	Default	2

Motor stops when quick stop command is given.

PP, PV

- 0 : To stop motor through Pr5.06. Status: Switch on disable, axis disabled.
- 1 : Motor decelerates and stops through 6084. Status: Switch on disable, axis disabled.
- 2 : Motor decelerates and stops through 6085. Status: Switch on disable, axis disabled.
- 3 : Motor decelerates and stops through 60C6. Status: Switch on disable, axis disabled.
- 5 : Motor decelerates and stops through 6084. Status: Quick stop
- 6 : Motor decelerates and stops through 6085. Status: Quick stop
- 7 : Motor decelerates and stops through 60C6. Status: Quick stop

HM

- 0 : To stop motor through Pr5.06. Status: Switch on disable, axis disabled.
- 1 : Motor decelerates and stops through 609A. Status: Switch on disable, axis disabled.
- 2 : Motor decelerates and stops through 6085. Status: Switch on disable, axis disabled.
- 3 : Motor decelerates and stops through 60C6. Status: Switch on disable, axis disabled.
- 5 : Motor decelerates and stops through 609A. Status: Quick stop
- 6 : Motor decelerates and stops through 6085. Status: Quick stop
- 7 : Motor decelerates and stops through 60C6. Status: Quick stop

Index 605Bh	Label	Shutdown option code			Mode						F
	Range	RW	Unit	-	Range	0~1	Default				0
PP, PV 0 : To stop motor through Pr5.06, 5.06 = 0(Emergency stop), 5.06=1(Free stop) 1 : Motor decelerates and stops through 6084 HM 0 : To stop motor through Pr5.06, 5.06 = 0(Emergency stop), 5.06=1(Free stop) 1 : Motor decelerates and stops through 609A											

Index 605Ch	Label	Disable operation option code			Mode						F
	Range	RW	Unit	-	Range	0~1	Default				0
PP, PV 0 : To stop motor through Pr5.06, 5.06 = 0(Emergency stop), 5.06=1(Free stop) 1 : Motor decelerates and stops through 6084 HM 0 : To stop motor through Pr5.06, 5.06 = 0(Emergency stop), 5.06=1(Free stop) 1 : Motor decelerates and stops through 609A											

Index 605Dh	Label	Halt option code			Unit	-	Structure	VAR	Type	INT 16
	Access	RW	Mapping	-	Mode	F	Range	1~3	Default	1
When control word – pause sets decelerating, stopping mode. Also suitable for deceleration mode settings during mode switching PP, PV 1 : Motor decelerates and stops through 6084. Status: Operation enabled, axis enabled. 2 : Motor decelerates and stops through 6085. Status: Operation enabled, axis enabled. 3 : Motor decelerates and stops through 60C6. Status: Operation enabled, axis enabled. HM 1 : Motor decelerates and stops through 609A. Status: Operation enabled, axis enabled. 2 : Motor decelerates and stops through 6085. Status: Operation enabled, axis enabled. 3 : Motor decelerates and stops through 60C6. Status: Operation enabled, axis enabled.										

Index 6060h	Label	Mode of Operation			Unit	-	Structure	VAR	Type	Int 8
	Access	RW	Mapping	RPDO	Mode	F	Range	-2~6	Default	1

No.	Mode	Abbr.
1	Profile position mode	PP
3	Profile velocity mode	PV
4	profile Torque mode	PT
6	Homing mode	HM

Index 6061h	Label	Mode of Operation display			Unit	-	Structure	VAR	Type	Int 8
	Access	RW	Mapping	RPDO	Mode	F	Range	-2~6	Default	0

No.	Mode	Abbr.
1	Profile position mode	PP
3	Profile velocity mode	PV
4	profile Torque mode	PT
6	Homing mode	HM

Index 6062h	Label	Position Demand Value			Unit	Command unit	Structure	VAR	Type	Int 32
	Access	R0	Mapping	TPDO	Mode	PP/HM	Range	-2147483648~2147483647	Default	0

Reflects position command when servo driver is enabled.

Index 6063h	Label	Position Actual Internal Value			Unit	Encoder unit	Structure	VAR	Type	Int 32
	Access	R0	Mapping	TPDO	Mode	F	Range	-2147483648~2147483647	Default	0

Reflects motor absolute position (Encoder unit)

Index 6064h	Label	Position Actual Value			Unit	Command unit	Structure	VAR	Type	Int 32
	Access	R0	Mapping	TPDO	Mode	F	Range	- 214748364 8~2147483 647	Default	0

Reflects user's real time absolute position
6064h*Gear ratio = 6063h

Index 606Bh	Label	Velocity Demand Value			Unit	Command unit/s	Structure	VAR	Type	Int 32
	Access	R0	Mapping	TPDO	Mode	ALL	Range	- 214748364 8~2147483 647	Default	0

To set the time between arrival to the output of INP (In position) signal.

Index 606Ch	Label	Velocity Actual Value			Unit	Command unit/s	Structure	VAR	Type	Int 32
	Access	R0	Mapping	TPDO	Mode	PP	Range	- 214748364 8~2147483 647	Default	0

Reflects user's internal command velocity feedback value

Index 6071h	Label	Target torque			Unit	0.1%	Structure	VAR	Type	UInt 16
	Access	RW	Mapping	RPDO	Mode	PT	Range	- 32768~3 2767	Default	0

To set target torque for protocol and cyclic torque mode.

Index 6072h	Label	Max Torque			Unit	0.1%	Structure	VAR	Type	UInt 16
	Access	RW	Mapping	RPDO	Mode	F	Range	0~65535	Default	3000

To set max. torque for servo driver. Limited by motor max. torque.

Index 6073h	Label	Max current			Unit	0.1%	Structure	VAR	Type	UInt 16
	Access	R0	Mapping	TPDO	Mode	F	Range	0~65535	Default	3000

To set max. current for servo driver.

Index 6074h	Label	Torque Demand			Unit	0.1%	Structure	VAR	Type	Int 16
	Access	R0	Mapping	TPDO	Mode	F	Range	- 32768~3 2767	Default	0
Internal command torque										

Index 6075h	Label	Motor Rated Current			Unit	mA	Structure	VAR	Type	Int 32
	Access	R0	Mapping	TPDO	Mode	F	Range	0~21474 83647	Default	3000
Shows motor rated current.										

Index 6076h	Label	Motor Rated Torque			Unit	mN.m	Structure	VAR	Type	Int 32
	Access	R0	Mapping	TPDO	Mode	F	Range	0~21474 83647	Default	3000
Shows motor rated torque.										

Index 6077h	Label	Torque Actual Value			Unit	0.1%	Structure	VAR	Type	Int 16
	Access	R0	Mapping	TPDO	Mode	F	Range	- 5000~50 00	Default	0
Shows servo driver actual torque feedback										

Index 6078h	Label	Current Actual value			Unit	0.1%	Structure	VAR	Type	Int 16
	Access	R0	Mapping	TPDO	Mode	F	Range	- 5000~50 00	Default	0
Shows servo driver actual current feedback										

Index 6079h	Label	DC bus voltage			Unit	mV	Structure	VAR	Type	UInt 32
	Access	R0	Mapping	TPDO	Mode	F	Range	0~21474 83647	Default	0
Shows DC bus voltage across P, N terminals										

Index 607Ah	Label	Target position			Unit	Command unit	Structure	VAR	Type	Int 32
	Access	R W	Mapping	TPDO	Mode	PP	Range	- 2147483647 ~214748364 7	Default	0
To set the target position under profile position mode.										

Index 607Ch	Label	Homing position offset			Unit	Command unit	Structure	VAR	Type	Int 32
	Access	R W	Mapping	TPDO	Mode	HM	Range	- 2147483647~2147483647	Default	0
To set position offset to compensate for the deviation of mechanical origin from motor origin under homing										

Index 607Dh-01	Label	Min. software limit			Unit	Command unit	Structure	VAR	Type	Int 32
	Access	R W	Mapping	TPDO	Mode	HM	Range	- 2147483647~2147483647	Default	0
To set lower limit with calculated position and actual position using absolute position after homing.										

Index 607Dh-02	Label	Max. software limit			Unit	Command unit	Structure	VAR	Type	Int 32
	Access	R W	Mapping	TPDO	Mode	HM	Range	- 2147483647~2147483647	Default	0
To set upper limit with calculated position and actual position using absolute position after homing.										

Index 607Eh	Label	Polarity			Unit	-	Structure	VAR	Type	UInt 8												
	Access	R W	Mapping	RPDO	Mode	HM	Range	0x0 – 0xFF	Default	0x0												
<table border="1" style="width: 100%; border-collapse: collapse;"> <thead> <tr> <th colspan="2" style="background-color: #d9e1f2;">Mode</th> <th style="background-color: #d9e1f2;">Value</th> </tr> </thead> <tbody> <tr> <td style="text-align: center;">Position mode</td> <td style="text-align: center;">PP HM</td> <td>0: Rotate in the same direction as the position command 128: Rotate in the opposite direction to the position command</td> </tr> <tr> <td style="text-align: center;">Velocity mode</td> <td style="text-align: center;">PV</td> <td>0: Rotate in the same direction as the position command 64: Rotate in the opposite direction to the position command</td> </tr> <tr> <td style="text-align: center;">ALL mode</td> <td></td> <td>0: Rotate in the same direction as the position command 224: Rotate in the opposite direction to the position command</td> </tr> </tbody> </table> <p>Sets the input polarity of the command.</p>											Mode		Value	Position mode	PP HM	0: Rotate in the same direction as the position command 128: Rotate in the opposite direction to the position command	Velocity mode	PV	0: Rotate in the same direction as the position command 64: Rotate in the opposite direction to the position command	ALL mode		0: Rotate in the same direction as the position command 224: Rotate in the opposite direction to the position command
Mode		Value																				
Position mode	PP HM	0: Rotate in the same direction as the position command 128: Rotate in the opposite direction to the position command																				
Velocity mode	PV	0: Rotate in the same direction as the position command 64: Rotate in the opposite direction to the position command																				
ALL mode		0: Rotate in the same direction as the position command 224: Rotate in the opposite direction to the position command																				

Index 607Fh	Label	Max Profile Velocity			Unit	Command unit/s	Structure	VAR	Type	UInt 32
	Access	R W	Mapping	RPDO	Mode	PP/HM/P V	Range	0~214 74836 47	Default	21474836 47

To set maximum allowable velocity. Limited by 6080.

Index 6080h	Label	Max Motor Speed			Unit	R/min	Structure	VAR	Type	UInt 32
	Access	R W	Mapping	RPDO	Mode	F	Range	0~214 74836 47	Default	6000

To set the maximum allowable motor velocity.

Index 6081h	Label	Profile Velocity			Unit	Command unit/s	Structure	VAR	Type	UInt 32
	Access	R W	Mapping	RPDO	Mode	PP	Range	0~214 74836 47	Default	10000

To set target velocity. Limited by 607Fh.

Index 6083h	Label	Profile acceleration			Unit	Command unit/s ²	Structure	VAR	Type	UInt 32
	Access	R W	Mapping	RPDO	Mode	PP/PV	Range	1~2147 48364 7	Default	10000

To set motor acceleration

Index 6084h	Label	Profile deceleration			Unit	Command unit/s ²	Structure	VAR	Type	UInt 32
	Access	R W	Mapping	RPDO	Mode	PP/PV/H M	Range	1~2147 48364 7	Default	10000000

To set motor deceleration

Index 6085h	Label	Quick Stop Deceleration			Unit	Command unit/s ²	Structure	VAR	Type	UInt 32
	Access	R W	Mapping	RPDO	Mode	PP/PV	Range	1~2147 48364 7	Default	10000

To set the deceleration during an emergency stop

Index 6087h	Label	Torque slope			Unit	%/s	Structure	VAR	Type	UInt 32
	Access	R W	Mapping	RPDO	Mode	PT	Range	1~2147 48364 7	Default	5000

To set values for tendency torque command

Index 608Fh-01	Label	Encoder Increments			Unit	Encoder unit	Structure	VAR	Type	UInt 32
	Access	R 0	Mapping	TPDO	Mode	F	Range	1~2147 48364 7	Default	0
To set encoder resolution										

Index 6091h-01	Label	Motor Revolutions			Unit	r	Structure	VAR	Type	Dint 32
	Access	RW	Mapping	RPDO	Mode	F	Range	1- 2147483 647	Default	1
To set electronic gear ratio numerator										

Index 6091h-02	Label	Shaft Revolutions			Unit	r	Structure	VAR	Type	Dint 32
	Access	RW	Mapping	RPDO	Mode	F	Range	1- 2147483 647	Default	1
To set electronic gear ratio denominator										

Index 6092h-01	Label	Shaft Revolutions			Unit	Comma nd unit/r	Structu re	VAR	Type	UInt 32
	Access	RW	Mapping	RPDO	Mode	F	Range	1~21474 83647	Default	10000
If 6092h-01(Feed constant) is not equal to 608Fh(Position encoder resolution), then: Electronic gear ratio = Encoder resolution / 6092h-01 If 6092h-01(Feed constant) is equal to 608Fh(Position encoder resolution), then: Electronic gear ratio = 6091-01 / 6092h-01										

Index 6098h	Label	Homing method			Unit	-	Structure	VAR	Type	UInt 8
	Access	RW	Mapping	RPDO	Mode	F	Range	-6- 37	Default	19
The table below describes the velocity, direction and stopping conditions of each homing methods.										
Ref no.	Description									
	<i>Velocity</i>	<i>Direction</i>	<i>Stop</i>							
-6	Low	Negative	When torque reached							
-5	Low	Positive	When torque reached							
-4	High	Negative	Inversed when torque reached, after torque is gone							
-3	High	Positive	Inversed when torque reached, after torque is gone							
-2	High	Negative	Inversed when torque reached, received 1 st Z-signal after torque is gone							
-1	High	Positive	Inversed when torque reached, received 1 st Z-signal after torque is gone							
	<i>Direction</i>	<i>Deceleration point</i>	<i>Home</i>			<i>Before Z-signal</i>				
1	Negative	Negative limit switch	Motor Z-signal			Negative limit switch falling edge				
2	Positive	Positive limit switch	Motor Z-signal			Positive limit switch falling edge				
3	Positive	Homing switch	Motor Z-signal			Falling edge on same side of homing switch				
4	Positive	Homing switch	Motor Z-signal			Rising edge on same side of homing switch				
5	Negative	Homing switch	Motor Z-signal			Falling edge on same side of				

					homing switch
6	Negative	Homing switch	Motor Z-signal		Rising edge on same side of homing switch
7	Positive	Homing switch	Motor Z-signal		Falling edge on same side of homing switch
8	Positive	Homing switch	Motor Z-signal		Rising edge on same side of homing switch
9	Positive	Homing switch	Motor Z-signal		Rising edge on same side of homing switch
10	Positive	Homing switch	Motor Z-signal		Falling edge on same side of homing switch
11	Negative	Homing switch	Motor Z-signal		Falling edge on same side of homing switch
12	Negative	Homing switch	Motor Z-signal		Rising edge on same side of homing switch
13	Negative	Homing switch	Motor Z-signal on other side of homing switch		Rising edge on other side of homing switch
14	Negative	Homing switch	Motor Z-signal on other side of homing switch		Falling edge on other side of homing switch
15					
16					
17-32	Similar with 1-14, but deceleration point = homing point				
33	Home in negative direction, Homing point = motor Z-signal				
34	Home in positive direction, Homing point = motor Z-signal				
35-37	Set current position as homing point				

Index 6099h-01	Label	Speed During Search For Switch			Unit	Command unit/s	Structure	VAR	Type	UInt 32
	Access	R W	Mapping	RPDO	Mode	HM	Range	0~214 74836 47	Default	10000

To set the speed used in homing

Index 6099h-02	Label	Speed During Search For Zero			Unit	Command unit/s	Structure	VAR	Type	UInt 32
	Access	R W	Mapping	RPDO	Mode	HM	Range	0~214 74836 47	Default	5000

To set the speed used in homing

Index 609Ah	Label	Homing acceleration /deceleration			Unit	Command unit/s ²	Structure	VAR	Type	UInt 32
	Access	R 0	Mapping	TPDO	Mode	HM	Range	1~2147 48364 7	Default	500000

To set acceleration and deceleration used in homing

Index 60C5h	Label	Max Acceleration			Unit	Command unit/s ²	Structure	VAR	Type	UInt 32
	Access	RW	Mapping	RPDO	Mode	F	Range	1~2147483647	Default	100000000
To set upper limit of acceleration.										

Index 60C6h	Label	Max Deceleration			Unit	Command unit/s ²	Structure	VAR	Type	UInt 32
	Access	RW	Mapping	RPDO	Mode	F	Range	1~2147483647	Default	100000000
To set lower limit of acceleration.										

Index 60E0h	Label	Positive Torque Limit			Unit	0.1%	Structure	VAR	Type	UInt 16
	Access	RW	Mapping	RPDO	Mode	F	Range	0~65535	Default	3000
To set the maximum torque of servo driver in positive direction										

Index 60E1h	Label	Negative Torque Limit			Unit	0.1%	Structure	VAR	Type	UInt 16
	Access	RW	Mapping	RPDO	Mode	F	Range	0~65535	Default	3000
To set the maximum torque of servo driver in negative direction										

Index 60F4h	Label	Following Error Actual Value			Unit	Command unit	Structure	VAR	Type	Int 32
	Access	R0	Mapping	TPDO	Mode	PP/HM	Range	-2147483647~2147483647	Default	0
Shows position following error										

Index 60FAh	Label	Control Effort			Unit	Command unit/s	Structure	VAR	Type	Int 32
	Access	R0	Mapping	TPDO	Mode	PP/HM	Range	-2147483647~2147483647	Default	0
Shows internal command velocity (Position loop output)										

Index 60FCh	Label	Position Demand Internal Value			Unit	Encoder unit	Structure	VAR	Type	Int 32
	Access	R0	Mapping	TPDO	Mode	CSP/PP/HM	Range	-2147483647~2147483647	Default	0
Shows internal command position of servo driver.										

Index 60FDh	Label	Digital Inputs			Unit	-	Structure	VAR	Type	UINT 32
	Access	R0	Mapping	TPDO	Mode	CSP/PP/H M	Range	- 214748364 8~2147483 647	Default	0

The bits of 60FDh object are functionally defined as follow:

Bit31	Bit30	Bit29	Bit28	Bit27	Bit26	Bit25	Bit24
Z signal	Reserved	Reserved	Reserved	Probe 2	Probe 1	BRAKE	INP/V- COIN /TLC
Bit23	Bit22	Bit21	Bit20	Bit19	Bit18	Bit17	Bit16
E-STOP	Reserved	Reserved	Reserved	Reserved	Reserved	DI14	DI13
Bit15	Bit14	Bit13	Bit12	Bit11	Bit10	Bit9	Bit8
DI12	DI11	DI10	DI9	DI8	DI7	DI6	DI5
Bit7	Bit6	Bit5	Bit4	Bit3	Bit2	Bit1	Bit0
DI4	DI3	DI2	DI1	Reserved	HOME	POT	NOT

Index 60FEh-01	Label	Physical Outputs			Unit	-	Structure	VAR	Type	UInt 32
	Access	RW	Mapping	RPDO	Mode	F	Range	0x0~0x7FF FFFF	Default	0x0

The bits of 60FEh object are functionally defined as follow:

Bit Sub-index	31~21	21	20	19	18	17	16	15~0
01h	Reserved	D06 valid	D05 valid	D04 valid	D03 valid	D02 valid	D01 valid	Reserved

Index 60FEh-02	Label	Bit Mask			Unit	-	Structure	VAR	Type	UInt 32
	Access	RW	Mapping	RPDO	Mode	F	Range	0x0~0x7FFF FFFF	Default	0xFFFF0 000

The bits of a 60FEh object are functionally defined as follow:

Bit Sub-index	31~21	21	20	19	18	17	16	15~0
02h	Reserved	D06 enabled	D05 enabled	D04 enabled	D03 enabled	D02 enabled	D01 enabled	Reserved

Index 60FFh	Label	Target velocity			Unit	Command unit	Structure	VAR	Type	Int 32
	Access	RW	Mapping	RPDO	Mode	PV	Range	- 2147483647~ 2147483647	Default	0

Shows set target velocity. Limited by 6080h

Index 6502h	Label	Supported drive modes			Unit	-	Structure	VAR	Type	UInt 32
	Access	R0	Mapping	TPDO	Mode	F	Range	0x0~0x7F FFFFFF	Default	0x0

Shows the control modes supported by the servo drive.

Chapter 4 Control Mode

4.1 Profile Position Mode

4.1.1 Pulse

Pulse uses 6091H or 6092H parameters in object dictionary. Electronic gear ratio has a range of 1/1000 ~ 8000, if not Er A00 will appear. Error disappear after the parameter is set to be within the range but 402 state machine error status might still exist, please write 0x80 into control word (6040h) to deactivate the error status.

Method 1:

- Electronic gear changes the distance travelled by an axis through object dictionary 608Fh(Position encoder resolution), 6091h(Gear ratio), 6092h(Feed constant) from a controller. Only valid under Pre-operation mode.
- 608Fh(Position Encoder Resolution) is encoder resolution, it is only readable.
- 6092h-01 is pulse counts per motor revolution, reset after disabling; 6091h-01/6091h-02 is updated on real time
- Electronic gear can be modified by changes 6092h-01:
 - If 6092h-01(Feed constant) is not equal to 608Fh(Position encoder resolution), then
Electronic Gear Ratio = Encoder Resolution/6092h-01
 - If 6092h-01(Feed constant) is equal to 608Fh(Position encoder resolution), then
Electronic Gear Ratio = 6091h-01/6091h-02
- Electronic gear ratio range: 0.001 ~ 8000

Method 2:

Electronic gear can also be set using Pr0.08 Pulse counts per motor revolution. Pr0.08 is valid when it is not equal to 0; if Pr0.08 = 0, object dictionary 6092h-01 becomes valid.

Note: 6091h-01, 6091h-02 and 6092h-01 will be updated to default (1, 1, 1000) if the set value exceeds the range of the object dictionary.

4.1.2 Motion settings

- Set 6060h = 1 for Profile Position mode.
- Set target position to 607Ah (Unit: pulse)
- Set max. velocity to 6081h (Unit: pulse/s)
- Set profile acceleration and deceleration to 6083h and 6084h (Unit: pulse/s²)
- Set pulse count per revolution to 6092h
- Set 6040h to corresponding value to machine status and start motion.

No.	Object Dictionary	Label	Set Value	Unit
1	6060h	Operation mode	1	-
2	6040h	Control word	As per need	-

3	607Ah	Target position		pulse
4	6081h	Profile velocity		pulse/s
5	6083h	Profile acceleration		pulse/s ²
6	6084h	Profile deceleration		pulse/s ²
7	6092h	Pulse count per rev		-

4.1.3 Monitoring settings

- To monitor 6041h for motion status
- To monitor 6064h for real time update of position during operation
- To monitor 606Ch for real time velocity feedback

No.	Object Dictionary	Label	Unit
1	6041h	Status word	-
2	6064h	Position feedback	Pulse
3	606Ch	Velocity feedback	Pulse/s

4.1.4 Applications example

No.	Command	Description
1	81 00 00 00 00 00 00 00	Reset all nodes. Only to reset specific node, please modify the 2 digits after 81 to node number (hexadecimal)
2	01 00 00 00 00 00 00 00	Activate remote control for all nodes. Only to activate specific node, please modify the 2 digits after 01 to node number (hexadecimal)
3	2b 40 60 00 06 00 00 00	Write Control word = 06h, machine status changes Switch On Disabled->Ready to Switch On
4	2b 40 60 00 07 00 00 00	Write Control word = 07h, machine status changes Ready to Switch On-> Switched On <i>Drive internal relay closes</i>
5	2b 40 60 00 0f 00 00 00	Write Control word = 0fh, machine status changes Switched On -> Operation Enable <i>Motor enables</i>
6	2f 60 60 00 01 00 00 00	Write Operation Mode = 1h, position control mode
7	23 81 60 00 90 D0 03 00	Write Profile Velocity = 3D090h (1500rpm, default 10000ppr)
8	23 83 60 00 90 D0 03 00	Write Profile Acceleration = 3D090h (accelerates to 1500rpm in 1s, default 10000ppr)
9	23 7a 60 00 20 4E 00 00	Write Target Position = 4E20h (2 revs, default 10000ppr)
10	2b 40 60 00 4f 00 00 00	Write Control Word = 4Fh, relative motion mode
11	2b 40 60 00 5f 00 00 00	Write Control Word = 5Fh, motor starts motion
12	2b 40 60 00 07 00 00 00	Write Control word = 07h, machine status changes Operation Enable -> Switched On <i>Motor disables</i>
13	2b 40 60 00 06 00 00 00	Write Control word = 06h, machine status changes Ready to Switch On-> Switched On <i>Drive internal relay closes</i>

Note: Step 1 and step 2 frame ID = 0x0000, the rest = SDO address (0x0600+node no.)

4.2 Profile Velocity Mode

4.2.1 Motion Settings

- Set 6060h = 3 for Profile Velocity mode.
- Set target velocity to 60FFh (Unit: pulse/s)
- Set profile acceleration and deceleration to 6083h and 6084h (Unit: pulse/s²)
- Set 6040h to corresponding value to machine status and start motion.

No.	Object Dictionary	Label	Set Value	Unit
1	6060h	Operation mode	3	-
2	6040h	Control word	As per need	-
3	60FFh	Profile velocity		pulse/s
4	6083h	Profile acceleration		pulse/s ²
5	6084h	Profile deceleration		pulse/s ²

4.2.2 Monitoring settings

- To monitor 6041h for motion status
- To monitor 606Ch for real time velocity feedback

No.	Object Dictionary	Label	Unit
1	6041h	Status word	-
2	606Ch	Velocity feedback	Pulse/s

Applications example

No.	Command	Description
1	81 00 00 00 00 00 00 00	Reset all nodes. Only to reset specific node, please modify the 2 digits after 81 to node number (hexademical)
2	01 00 00 00 00 00 00 00	Activate remote control for all nodes. Only to activate specific node, please modify the 2 digits after 01 to node number (hexademical)
3	2b 40 60 00 06 00 00 00	Write Control word = 06h, machine status changes Switch On Disabled->Ready to Switch On
4	2b 40 60 00 07 00 00 00	Write Control word = 07h, machine status changes Ready to Switch On-> Switched On <i>Drive internal relay closes</i>
5	2b 40 60 00 0f 00 00 00	Write Control word = 0fh, machine status changes Switched On -> Operation Enable <i>Motor enables</i>
6	2f 60 60 00 03 00 00 00	Write Operation Mode = 3h, position control mode
7	23 83 60 00 90 D0 03 00	Write Profile Acceleration = 3D090h (accelerates to 1500rpm in 1s, default 10000ppr)
8	23 ff 60 00 90 D0 03 00	Write Profile Velocity = 3D090h (1500rpm, default 10000ppr)
9	2b 40 60 00 07 00 00 00	Write Control word = 07h, machine status changes Operation Enable -> Switched On <i>Motor disables</i>
10	2b 40 60 00 06 00 00 00	Write Control word = 06h, machine status changes Ready to Switch On-> Switched On <i>Drive internal relay closes</i>

Note: Step 1 and step 2 frame ID = 0x0000, the rest = SDO address (0x0600+node no.)

4.3 Profile Torque Mode

4.3.1 Motion Settings

- Set 6060h = 4 for Profile Torque mode.
- Set torque limit to 6071h (Unit: 0.1%)
- Set profile torque change rate to 6087h (Unit: 0.1%/s)
- Set velocity limit to 6080h (Unit: rpm)
- Set 6040h to corresponding value to machine status and start motion.

No.	Object Dictionary	Label	Set Value	Unit
1	6060h	Operation mode	4	-
2	6040h	Control word	As per need	-
3	6071h	Torque limit		0.1% of rated torque
4	6087h	Torque change rate		0.1% of rated torque/s
5	6080h	Max velocity		rpm

4.3.2 Monitoring settings

- To monitor 6041h for motion status

No.	Object Dictionary	Label	Unit
1	6041h	Status word	-
2	606Ch	Velocity feedback	Pulse/s

Applications example

No.	Command	Description
1	81 00 00 00 00 00 00 00	Reset all nodes. Only to reset specific node, please modify the 2 digits after 81 to node number (hexademical)
2	01 00 00 00 00 00 00 00	Activate remote control for all nodes. Only to activate specific node, please modify the 2 digits after 01 to node number (hexademical)
3	2b 40 60 00 06 00 00 00	Write Control word = 06h, machine status changes Switch On Disabled->Ready to Switch On
4	2b 40 60 00 07 00 00 00	Write Control word = 07h, machine status changes Ready to Switch On-> Switched On <i>Drive internal relay closes</i>
5	2b 40 60 00 0f 00 00 00	Write Control word = 0fh, machine status changes Switched On -> Operation Enable <i>Motor enables</i>
6	2f 60 60 00 04 00 00 00	Write Operation Mode = 4h, torque control mode
7	23 87 60 00 14 00 00 00	Write torque change rate = 14h (torque increase to rated torque 20Nm*0.1% =2Nm in 1s)
8	23 80 60 00 e8 03 00 00	Write Max Velocity = 3E8h (1000rpm)
9	2B 71 60 00 64 00 00 00	Write torque value = 64h (100*0.1% = 10% of rated torque)
10	2b 40 60 00 07 00 00 00	Write Control word = 07h, machine status changes Operation Enable -> Switched On <i>Motor disables</i>

11	2b 40 60 00 06 00 00 00	Write Control word = 06h, machine status changes Ready to Switch On-> Switched On <i>Drive internal relay closes</i>
----	-------------------------	--

Note: Step 1 and step 2 frame ID = 0x0000, the rest = SDO address (0x0600+node no.)

4.4 Homing mode

4.4.1 Motion Settings

- Set 6060h = 6 for Homing mode.
- Set required homing mode code to 6098h. Please refer to 6.4.4 for descriptions on each homing mode.
- Set homing high velocity and homing low velocity to 6099h(0x1) and 6099h(0x2) respectively (Unit: pulse/s)
- Set profile acceleration/deceleration 609Ah as homing acceleration/deceleration (Unit: pulse/s²)
- Set 6040h to corresponding value to machine status and start motion.

No.	Object Dictionary	Label	Set Value	Unit
1	6060h	Operation mode	6	-
2	6040h	Control word	As per need	-
3	6098h	Homing mode		-
4	6099h	Homing velocity		pulse/s
5	609Ah	Homing acceleration/ deceleration		pulse/s ²

4.4.2 Monitoring settings

- To monitor 6041h for motion status

No.	Object Dictionary	Label	Unit
1	6041h	Status word	-
2	606Ch	Velocity feedback	Pulse/s

Application example

No.	Command	Description
1	81 00 00 00 00 00 00 00	Reset all nodes. Only to reset specific node, please modify the 2 digits after 81 to node number (hexademical)
2	01 00 00 00 00 00 00 00	Activate remote control for all nodes. Only to activate specific node, please modify the 2 digits after 01 to node number (hexademical)
3	2b 40 60 00 06 00 00 00	Write Control word = 06h, machine status changes Switch On Disabled->Ready to Switch On
4	2b 40 60 00 07 00 00 00	Write Control word = 07h, machine status changes Ready to Switch On-> Switched On <i>Drive internal relay closes</i>
5	2b 40 60 00 0f 00 00 00	Write Control word = 0fh, machine status changes Switched On -> Operation Enable <i>Motor enables</i>

6	2f 60 60 00 06 00 00 00	Write Operation Mode = 6h, homing mode
7	23 99 60 01 30 75 00 00	Write homing high velocity = 7530h (180rpm, default 10000ppr)
8	23 99 60 02 20 4e 00 00	Write homing low velocity = 4e20h (120rpm, default 10000ppr)
9	23 9a 60 00 30 75 00 00	Write homing acceleration = 7530h (Accelerates to 180rpm in 1s, default 10000ppr)
10	2f 98 60 00 16 00 00 00	Write homing mode = 16h (Homing mode 22)
11	2b 40 60 00 1f 00 00 00	Write Control Word = 1f, set 4 th digit of 6040h to 1, enable homing
12	2b 40 60 00 0f 00 00 00	Write Control Word = 0f, set 4 th digit of 6040h to 0, enable homing on rising edge.
13	2b 40 60 00 1f 00 00 00	Write Control Word = 1f, set 4 th digit of 6040h to 1, starts homing
14	2b 40 60 00 07 00 00 00	Write Control word = 07h, machine status changes Operation Enable -> Switched On <i>Motor disables</i>
15	2b 40 60 00 06 00 00 00	Write Control word = 06h, machine status changes Ready to Switch On-> Switched On <i>Drive internal relay closes</i>

Note: Step 1 and step 2 frame ID = 0x0000, the rest = SDO address (0x0600+node no.)

4.4.3 Homing mode

Torque limiting mode

Mode-6: Search for homing point in **negative direction at low velocity**. Stop after torque reaches the value set in Pr5.39 and homing done signal delivers after the time value set in Pr5.37

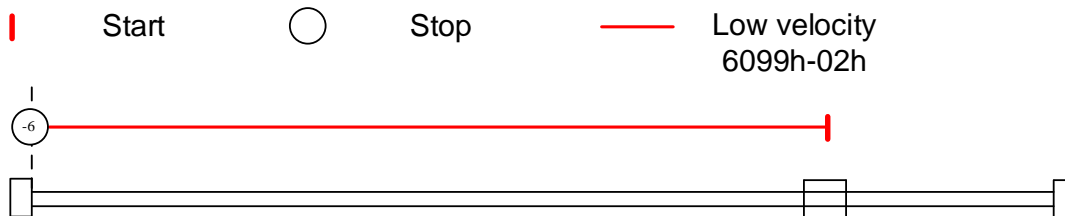

Mode -5: Search for homing point in **positive direction at low velocity**. Stop after torque reaches the value set in Pr5.39 and homing done signal delivers after the time value set in Pr5.37

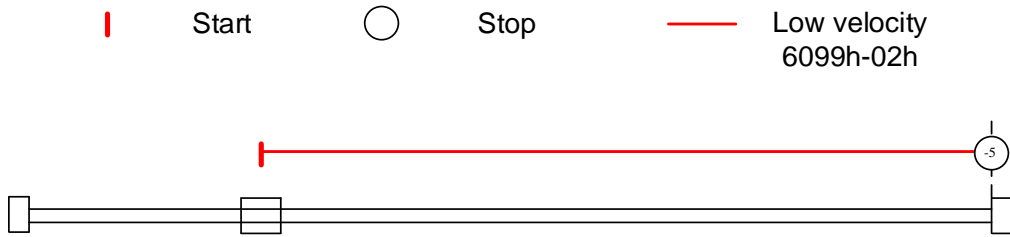

Mode -4: Search for homing point in **negative direction** at **high velocity**. Move in **positive direction** after torque reaches the value set in Pr5.39, stops when torque is gone. Homing done signal delivers after the time value set in Pr5.37

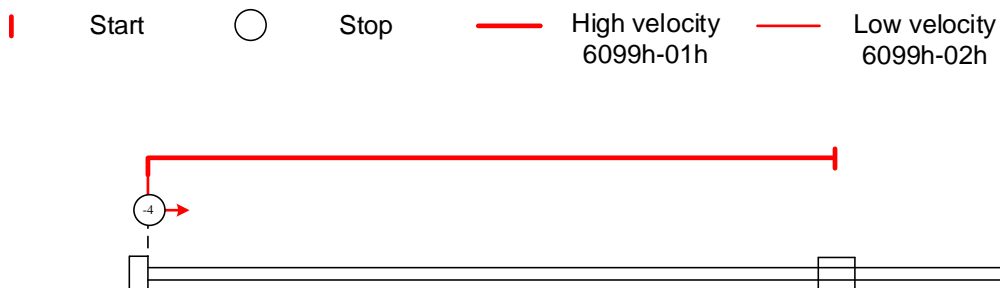

Mode -3: Search for homing point in **positive direction** at **high velocity**. Move in **negative direction** after torque reaches the value set in Pr5.39, stops when torque is gone. Homing done signal delivers after the time value set in Pr5.37

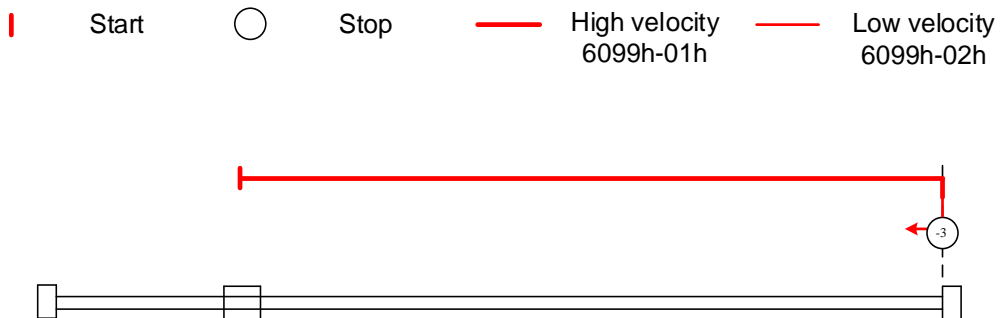

Mode -2: Search for homing point in **negative direction** at **low velocity**. Move in **positive direction** after torque reaches the value set in Pr5.39, stops when torque is gone with the **first Z-signal**.

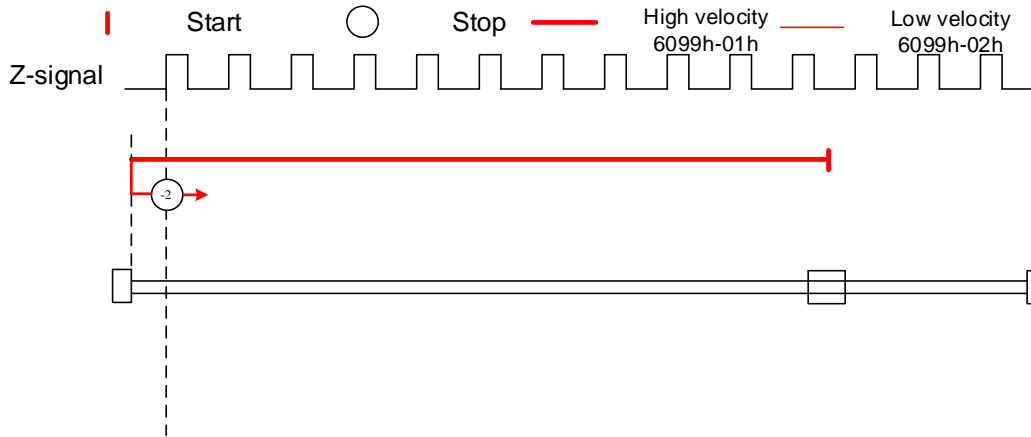

Mode -1: Search for homing point in **positive direction** at **low velocity**. Move in **negative direction** after torque reaches the value set in Pr5.39, stops when torque is gone with the **first Z-signal**.

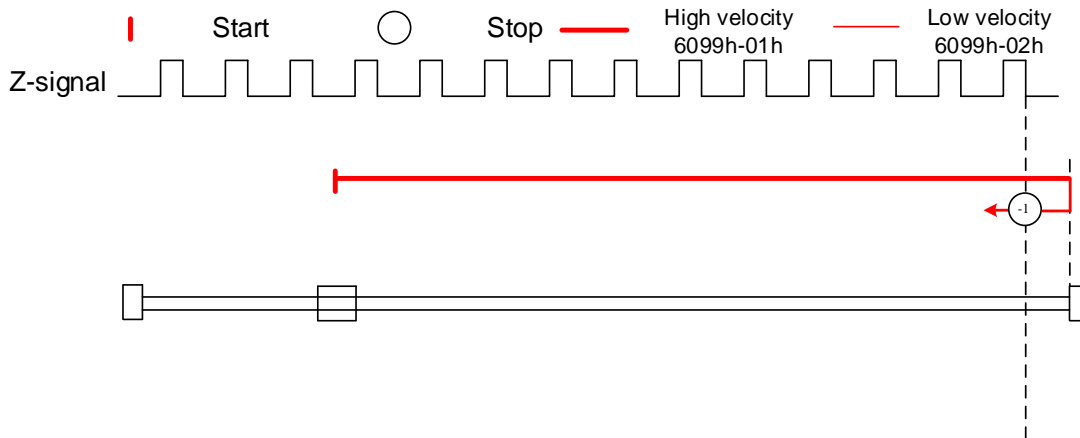

Mode 1:

 Diagram A: *Negative limit switch = OFF*

1. Move in **negative direction** at **high velocity** until **negative limit switch valid**.
2. Move in **positive direction** at **low velocity** and stops **after negative limit switch** and **first encoder Z-signal valid**

 Diagram B: *Negative limit switch = ON*

1. Start to move at **negative limit switch position** in **positive direction** at **high velocity** until **negative limit switch invalid**.
2. Move in **negative direction** at **high velocity** until **negative limit switch valid**.
3. Move in **positive direction** at **low velocity** and stops **after negative limit switch** and **first encoder Z-signal valid**

If the positive limit signal is valid during the homing process, the status word (6041h) bit 13 will be valid, indicating homing error and the motor will stop immediately.

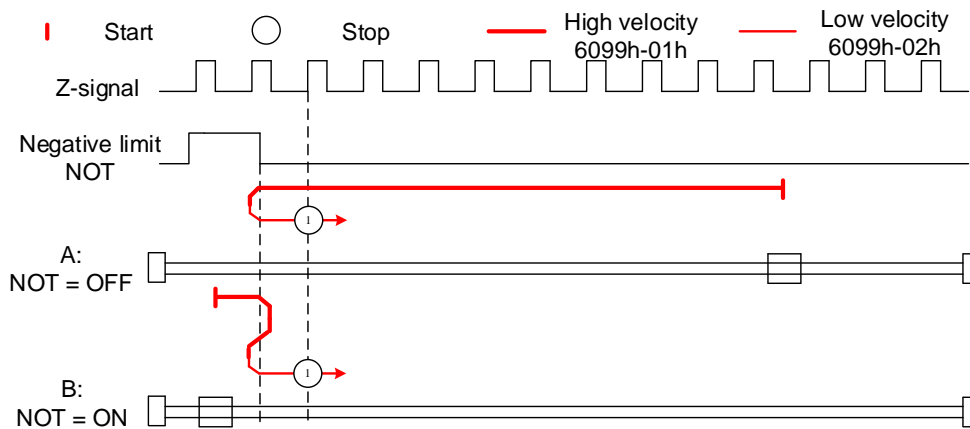

Mode 2:

 Diagram A: *Positive limit switch = OFF*

1. Move in **positive direction** at **high velocity** until **positive limit switch valid**.
2. Move in **negative direction** at **low velocity** and stops after **positive limit switch** and first **encoder Z-signal valid**

 Diagram B: *Positive limit switch = ON*

1. Start to move at **positive limit switch position** in **negative direction** at **high velocity** until **positive limit switch invalid**.
2. Move in **positive direction** at **high velocity** until **positive limit switch valid**.
3. Move in **negative direction** at **low velocity** and stops after **positive limit switch** and first **encoder Z-signal valid**

If the negative limit signal is valid during the homing process, the status word (6041h) bit 13 will be valid, indicating homing error and the motor will stop immediately.

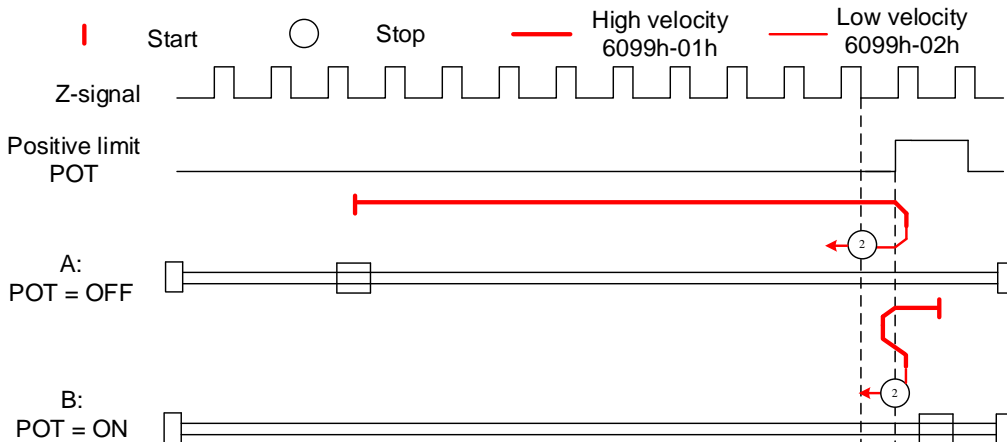

Mode 3:

 Diagram A: *Homing switch = OFF*

1. Move in **positive direction** at high velocity until homing switch valid.
2. Move in **negative direction** at low velocity and stops after homing switch and first encoder Z-signal valid

 Diagram B: *Homing switch = ON*

1. Start to move at homing switch position in **negative direction** at high velocity until after homing switch.
2. Move in **positive direction** at high velocity until homing switch valid.
3. Move in **negative direction** at low velocity and stops after homing switch and first encoder Z-signal valid

If the positive/negative limit switch signal is valid during the homing process, the status word (6041h) bit 13 will be valid, indicating homing error and the motor will stop immediately.

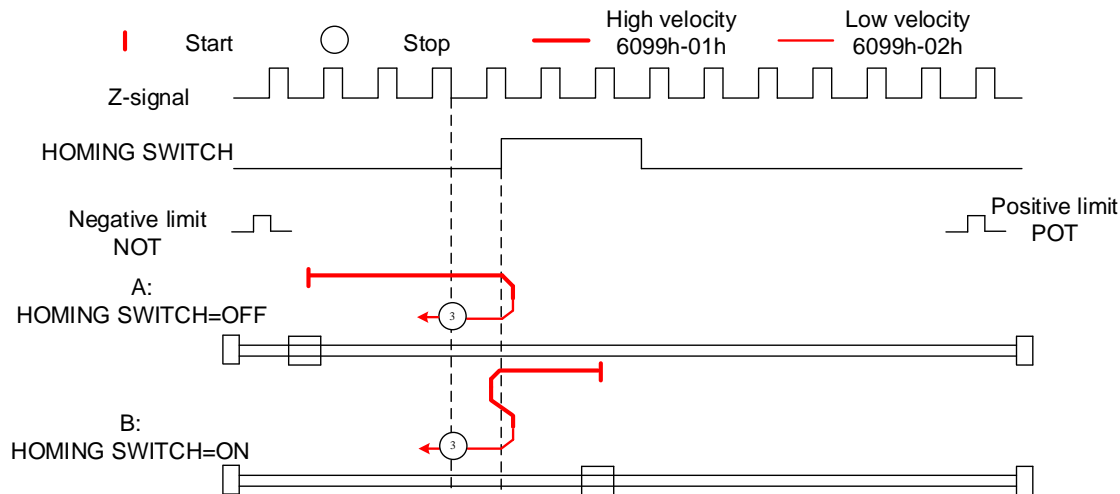
Mode 4:

Mode 4:

 Diagram A: *Homing switch = OFF*

1. Move in **positive direction** at **high velocity** until **homing switch valid**.
2. Move in **negative direction** at **high velocity** until **homing switch invalid**.
3. Move in **positive direction** at **low velocity** and stops after **homing switch valid** and **first encoder Z-signal valid**

 Diagram B: *Homing switch = ON*

1. Start to move at **homing switch position** in **negative direction** at **high velocity** until **after homing switch**.
2. Move in **positive direction** at **low velocity** and stops after **homing switch valid** and **first encoder Z-signal valid**

If the positive/negative limit switch signal is valid during the homing process, the status word (6041h) bit 13 will be valid, indicating homing error and the motor will stop immediately.

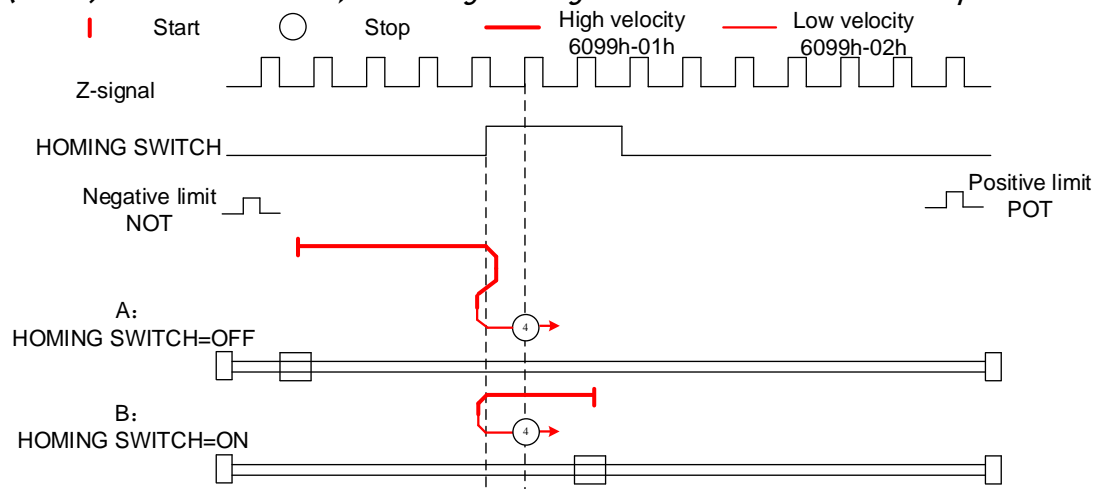

Mode 5:

 Diagram A: *Homing switch = OFF*

1. Move in **negative direction** at **high velocity** until homing switch valid.
2. Move in **positive direction** at **low velocity** and stops after homing switch and first encoder Z-signal valid

 Diagram B: *Homing switch = ON*

1. Start to move at **homing switch position** in **positive direction** at **high velocity** until after **homing switch**.
2. Move in **negative direction** at **high velocity** until **homing switch** valid.
3. Move in **positive direction** at **low velocity** and stops after homing switch and first encoder Z-signal valid

If the positive/negative limit switch signal is valid during the homing process, the status word (6041h) bit 13 will be valid, indicating homing error and the motor will stop immediately.

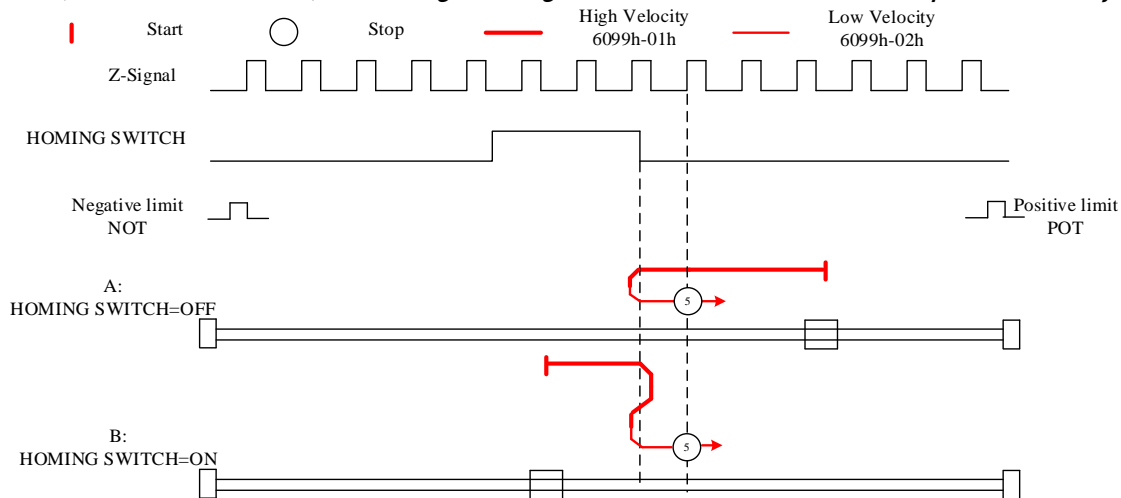

Mode 6:

 Diagram A: *Homing switch = OFF*

1. Move in **negative direction** at **high velocity** until **homing switch valid**.
2. Move in **positive direction** at **high velocity** until **homing switch invalid**.
3. Move in **negative direction** at **low velocity** and stops after **homing switch valid** and **first encoder Z-signal valid**

 Diagram B: *Homing switch = ON*

1. Start to move at **homing switch position** in **positive direction** at **high velocity** until **after homing switch**.
2. Move in **negative direction** at **low velocity** and stops after **homing switch valid** and **first encoder Z-signal valid**

If the positive/negative limit switch signal is valid during the homing process, the status word (6041h) bit 13 will be valid, indicating homing error and the motor will stop immediately.

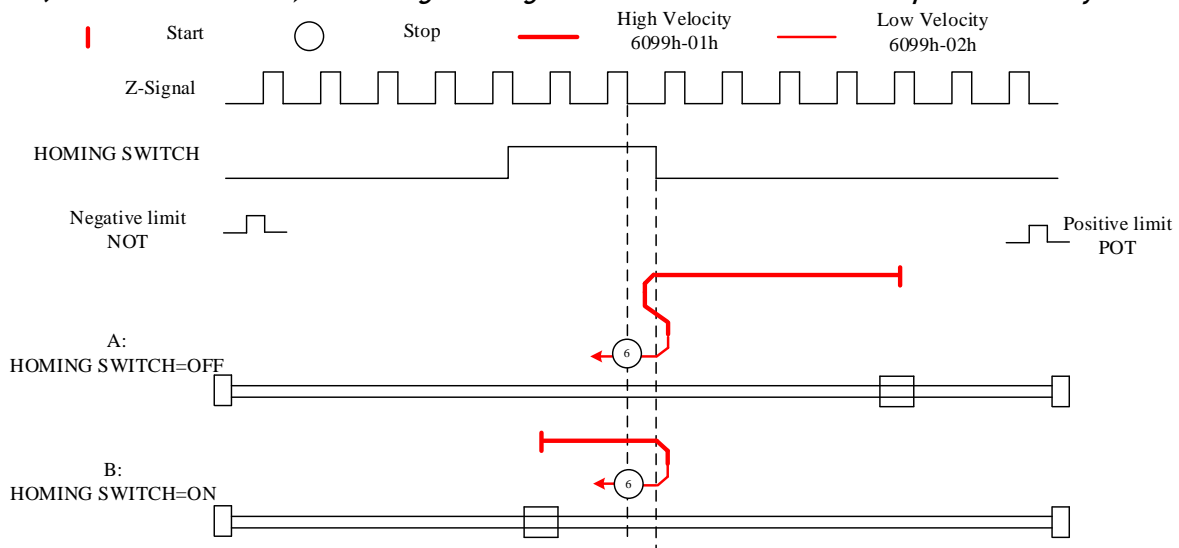

Mode 7

 Diagram A: *Homing switch & positive limit switch = OFF*

1. Move in **positive direction** at **high velocity** until **homing switch** valid.
2. Move in **negative direction** at **low velocity** and stops after **homing switch** and **first encoder Z-signal** valid.

 Diagram B: *Homing switch = ON, positive limit switch = OFF*

1. Start to move at **homing switch** position in **negative direction** at **high velocity** until **after homing switch**.
2. Move in **positive direction** at **high velocity** until **homing switch** valid.
3. Move in **negative direction** at **low velocity** and stops after **homing switch** and **first encoder Z-signal** valid

 Diagram C: *Homing switch & positive limit switch = OFF*

1. Move in **positive direction** at **high velocity** until **positive limit switch** valid.
2. Move in **negative direction** at **high velocity** until **after homing switch**.
3. Move in **positive direction** at **high velocity** until **homing switch** valid.
4. Move in **negative direction** at **low velocity** and stops after **homing switch** and **first encoder Z-signal** valid

If the negative limit switch signal is valid during the homing process, the status word (6041h) bit 13 will be valid, indicating homing error and the motor will stop immediately.

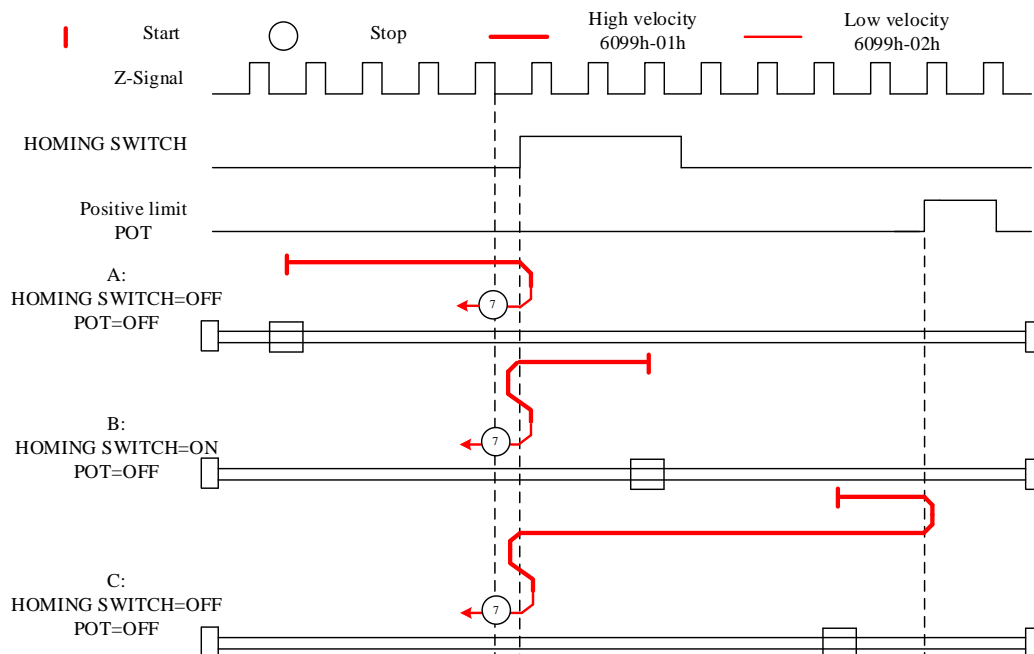

Mode 8

 Diagram A: *Homing switch & positive limit switch = OFF*

1. Move in **positive direction** at **high velocity** until **homing switch** valid.
2. Move in **negative direction** at **high velocity** until **after homing switch**.
3. Move in **positive direction** at **low velocity** and stops after **homing switch** valid and first **encoder Z-signal** valid.

 Diagram B: *Homing switch = ON, positive limit switch = OFF*

1. Start to move at **homing switch** position in **negative direction** at **high velocity** until **after homing switch**.
2. Move in **positive direction** at **low velocity** and stops after **homing switch** valid and first **encoder Z-signal** valid

 Diagram C: *Homing switch & positive limit switch = OFF*

1. Move in **positive direction** at **high velocity** until **positive limit switch** valid.
2. Move in **negative direction** at **high velocity** until **after homing switch**.
3. Move in **positive direction** at **low velocity** and stops after **homing switch** valid and first **encoder Z-signal** valid.

If the negative limit switch signal is valid during the homing process, the status word (6041h) bit 13 will be valid, indicating homing error and the motor will stop immediately.

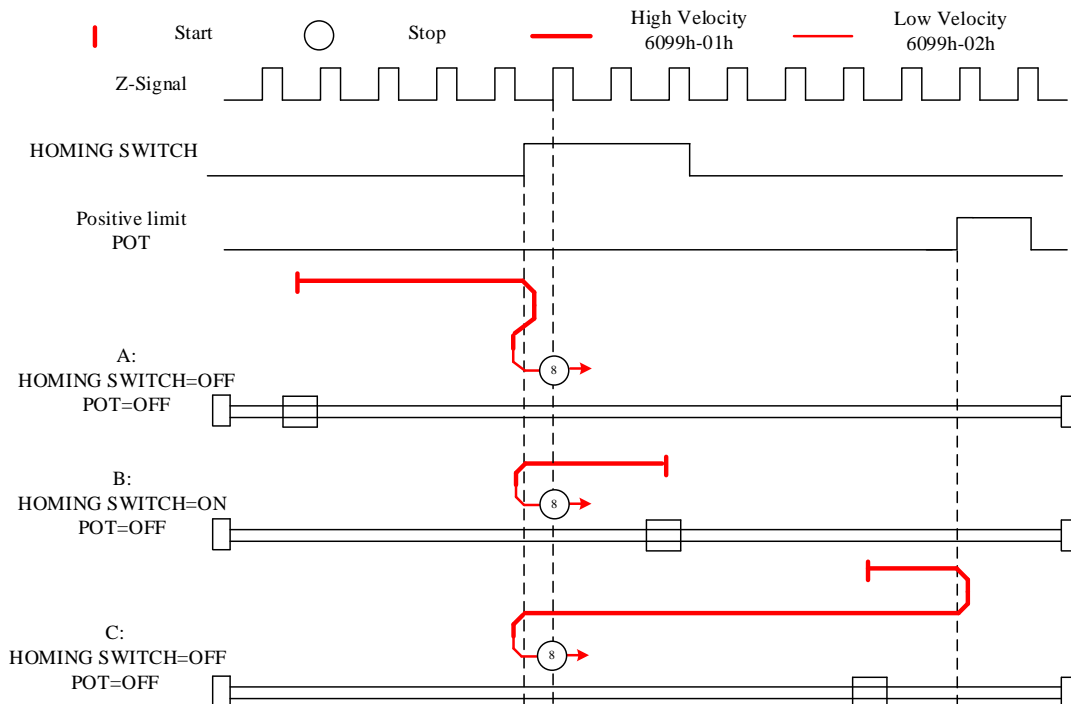

Mode 9

 Diagram A: *Homing switch & positive limit switch = OFF*

1. Move in **positive direction** at **high velocity** until **after homing switch**.
2. Move in **negative direction** at **low velocity** and stops after **homing switch valid** and first **encoder Z-signal valid**.

 Diagram B: *Homing switch = ON, positive limit switch = OFF*

1. Start to move at **homing switch position** in **positive direction** at **high velocity** until **homing switch invalid**.
2. Move in **negative direction** at **low velocity** and stops after **homing switch valid** and first **encoder Z-signal valid**

 Diagram C: *Homing switch & positive limit switch = OFF*

1. Move in **positive direction** at **high velocity** until **positive limit switch valid**.
2. Move in **negative direction** at **high velocity** until **homing switch valid**.
3. Move in **positive direction** at **high velocity** until **after homing switch**.
4. Move in **negative direction** at **low velocity** and stops after **homing switch valid** and first **encoder Z signal valid**

If the negative limit switch signal is valid during the homing process, the status word (6041h) bit 13 will be valid, indicating homing error and the motor will stop immediately.

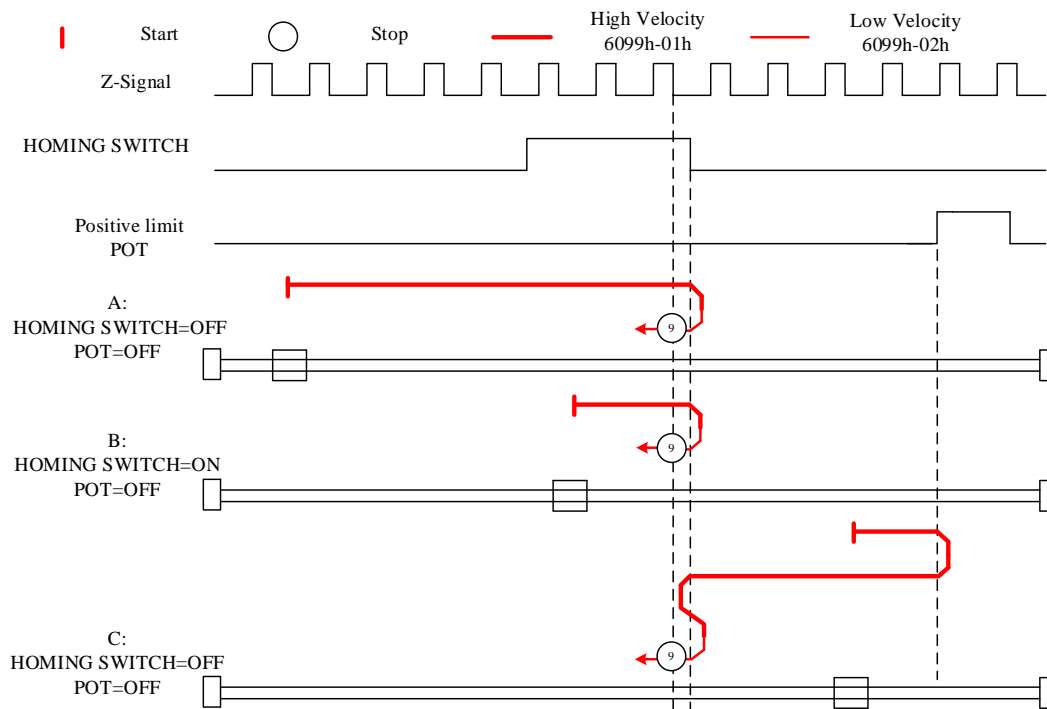

Mode 10

 Diagram A: *Homing switch & positive limit switch = OFF*

1. Move in **positive direction** at **high velocity** until **after homing switch**.
2. Move in **negative direction** at **high velocity** until **homing switch valid**.
3. Move in **positive direction** at **low velocity** and stops after homing switch and first encoder Z-signal valid.

 Diagram B: *Homing switch = ON, positive limit switch = OFF*

1. Start to move at **homing switch position** in **positive direction** at **high velocity** until **after homing switch**.
2. Move in **negative direction** at **high velocity** until **homing switch valid**.
3. Move in **positive direction** at **low velocity** and stops after homing switch and first encoder Z-signal valid

 Diagram C: *Homing switch & positive limit switch = OFF*

1. Move in **positive direction** at **high velocity** until **positive limit switch valid**.
2. Move in **negative direction** at **high velocity** until **homing switch valid**.
3. Move in **positive direction** at **low velocity** and stops after homing switch and first encoder Z-signal valid

If the negative limit switch signal is valid during the homing process, the status word (6041h) bit 13 will be valid, indicating homing error and the motor will stop immediately.

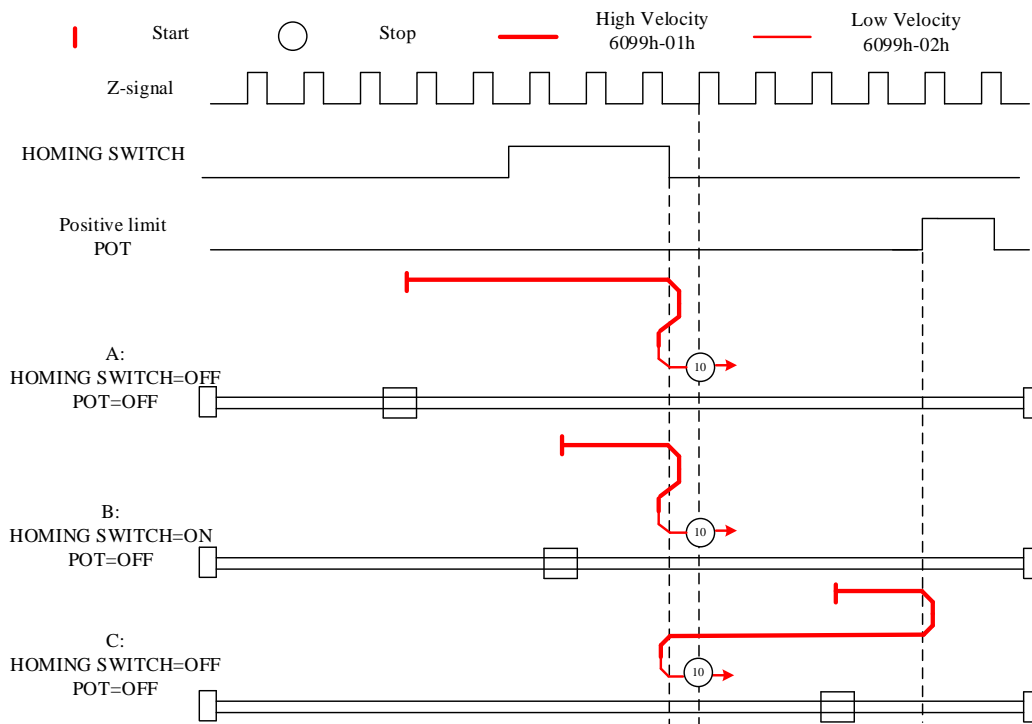

Mode 11

 Diagram A: *Homing switch & negative limit switch = OFF*

1. Move in **negative direction** at **high velocity** until **homing switch** valid.
2. Move in **positive direction** at **low velocity** and stops after **homing switch** and **first encoder Z-signal** valid

 Diagram B: *Homing switch = ON, negative limit switch = OFF*

1. Start to move at **homing switch** position in **positive direction** at **high velocity** until after **homing switch**.
2. Move in **negative direction** at **high velocity** until **homing switch** valid.
3. Move in **positive direction** at **low velocity** and stops after **homing switch** and **first encoder Z-signal** valid

 Diagram C: *Homing switch & negative limit switch = OFF*

1. Move in **negative direction** at **high velocity** until the **negative limit switch** valid.
2. Move in **positive direction** at **high velocity** until **homing switch** invalid.
3. Move in **negative direction** at **high velocity** until **homing switch** valid.
4. Move in **positive direction** at **low velocity** and stops after **homing switch** and **first encoder Z-signal** valid

If the positive limit switch signal is valid during the homing process, the status word (6041h) bit 13 will be valid, indicating homing error and the motor will stop immediately.

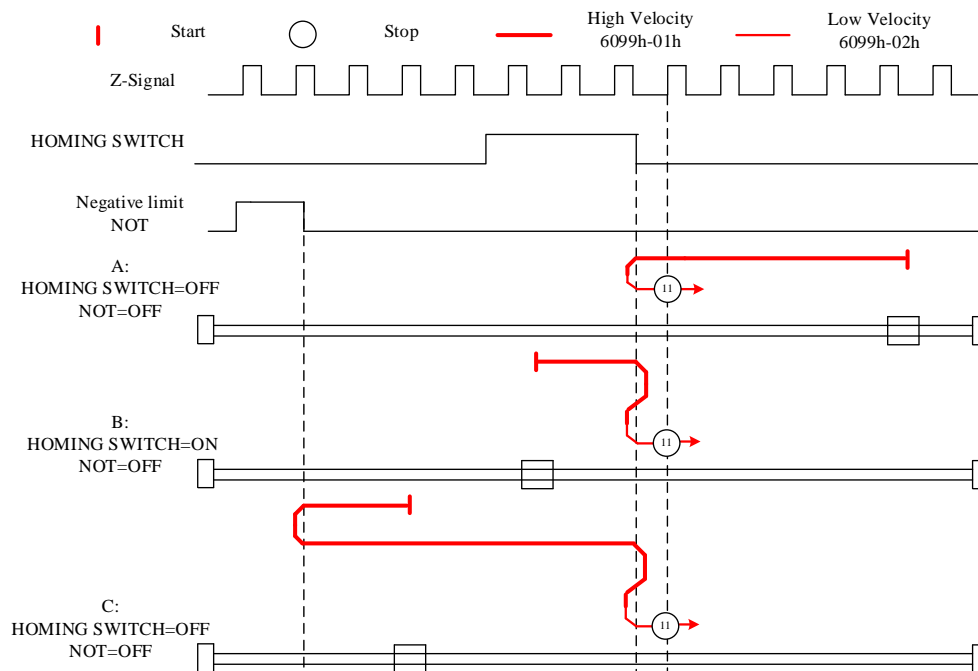

Mode 12

 Diagram A: *Homing switch & negative limit switch = OFF*

1. Move in **negative direction** at **high velocity** until **homing switch valid**.
2. Move in **positive direction** at **high velocity** until **after homing switch**.
3. Move in **negative direction** at **low velocity** and stops after **homing switch valid** and first **encoder Z-signal valid**

 Diagram B: *Homing switch = ON, negative limit switch = OFF*

1. Move at **homing switch position** in **negative direction** at **high velocity** until **after homing switch**.
2. Move in **positive direction** at **low velocity** and stops after **homing switch valid** and first **encoder Z-signal valid**.

 Diagram C: *Homing switch & negative limit switch = OFF*

1. Move in **negative direction** at **high velocity** until **negative limit switch valid**.
2. Move in **positive direction** at **high velocity** until **after homing switch**.
3. Move in **negative direction** at **low velocity** and stops after **homing switch valid** and first **encoder Z-signal valid**.

If the positive limit switch signal is valid during the homing process, the status word (6041h) bit 13 will be valid, indicating homing error and the motor will stop immediately.

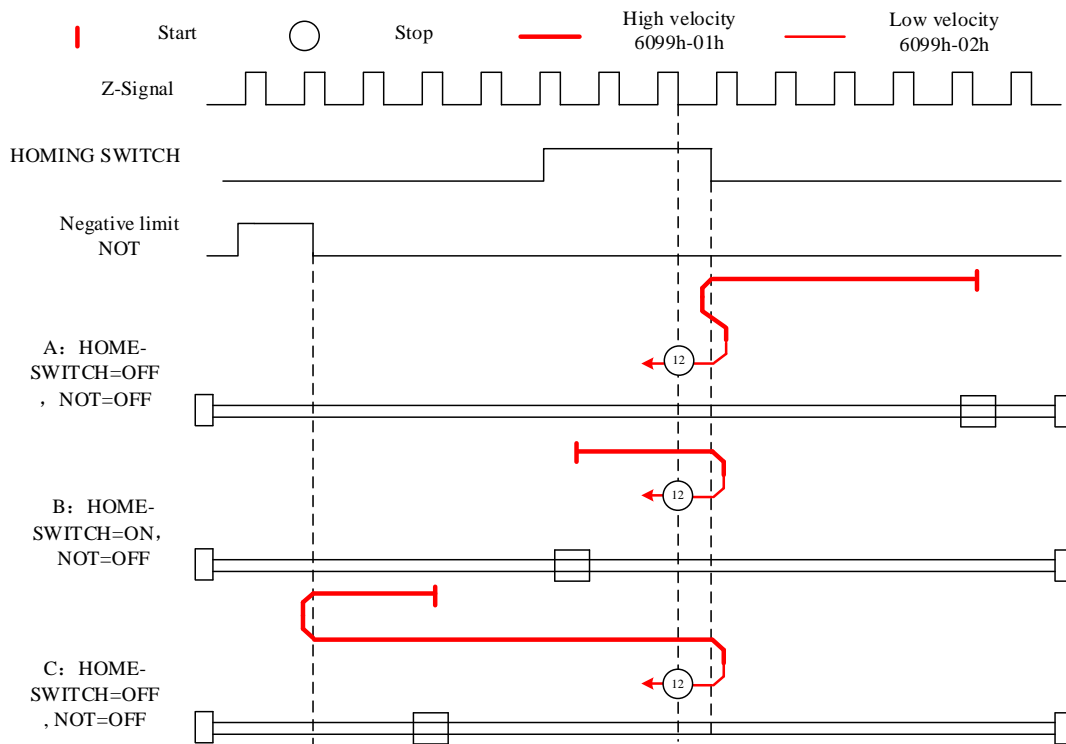

Mode 13

 Diagram A: *Homing switch & negative limit switch = OFF*

1. Move in **negative direction** at **high velocity** until **after homing switch**.
2. Move in **positive direction** at **low velocity** and stops after **homing switch valid** and **first encoder Z-signal valid**.

 Diagram B: *Homing switch = ON, negative limit switch = OFF*

1. Start to move at **homing switch position** in **negative direction** at **high velocity** until **after homing switch**.
2. Move in **positive direction** at **low velocity** and stops after **homing switch valid** and **first encoder Z-signal valid**.

 Diagram C: *Homing switch & negative limit switch = OFF*

1. Move in **negative direction** at **high velocity** until **negative limit switch valid**.
2. Move in **positive direction** at **high velocity** until **homing switch valid**.
3. Move in **negative direction** at **high velocity** until **after homing switch**.
4. Move in **positive direction** at **low velocity** and stops after **homing switch valid** and **first encoder Z-signal valid**.

If the positive limit switch signal is valid during the homing process, the status word (6041h) bit 13 will be valid, indicating homing error and the motor will stop immediately.

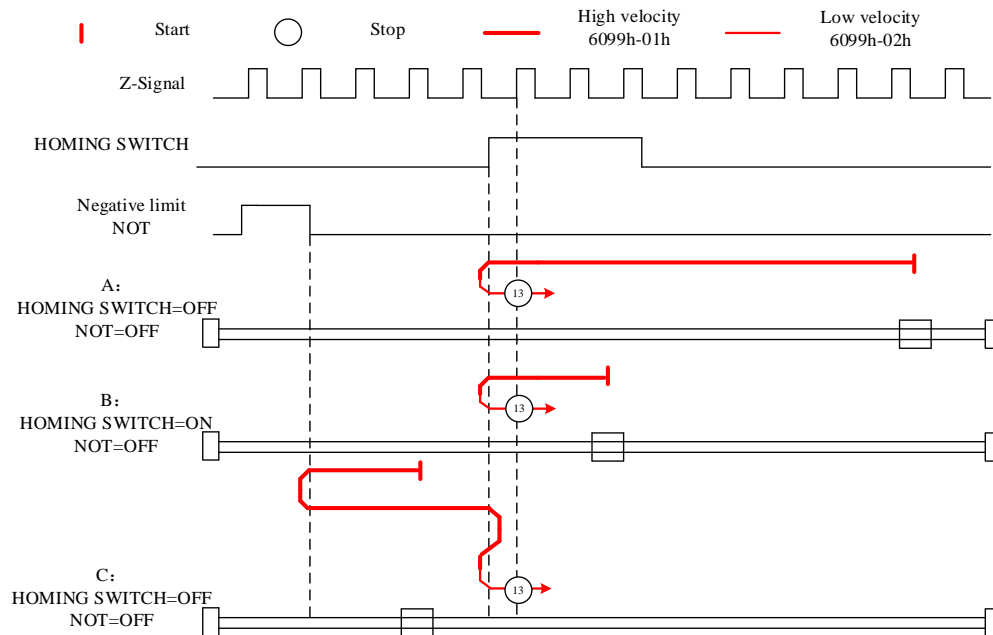

Mode 14

 Diagram A: *Homing switch & negative limit switch = OFF*

1. Move in **negative direction** at **high velocity** until **after homing switch**.
2. Move in **positive direction** at **high velocity** until **homing switch valid**.
3. Move in **negative direction** at **low velocity** and stops **after homing switch** and **first encoder Z-signal valid**.

 Diagram B: *Homing switch = ON, negative limit switch = OFF*

1. Start to move at **homing switch position** in **negative direction** at **high velocity** until **homing switch invalid**.
2. Move in **positive direction** until **homing switch valid**.
3. Move in **negative direction** at **low velocity** and stops **after homing switch** and **first encoder Z-signal valid**.

 Diagram C: *Homing switch & negative limit switch = OFF*

1. Move in **negative direction** at **high velocity** until **negative limit switch valid**.
2. Move in **positive direction** at **high velocity** until **homing switch valid**.
3. Move in **negative direction** at **low velocity** and stops **after homing switch** and **first encoder Z-signal valid**.

If the positive limit switch signal is valid during the homing process, the status word (6041h) bit 13 will be valid, indicating homing error and the motor will stop immediately.

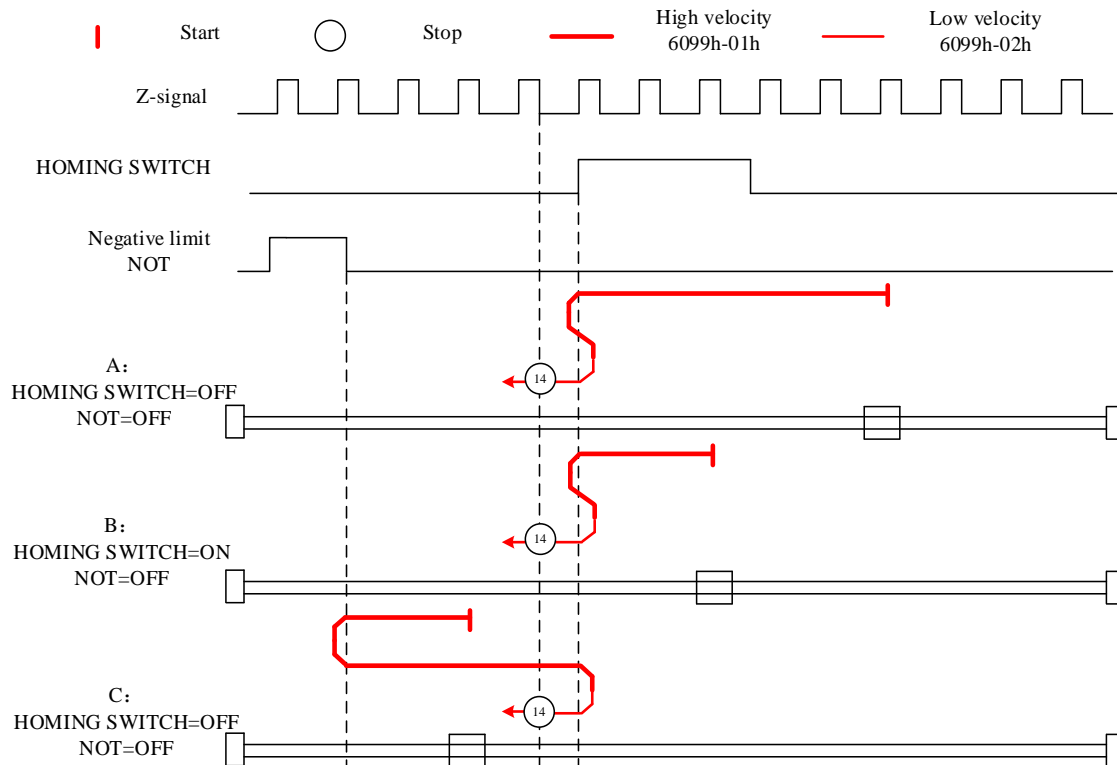

Mode 17:

This mode is similar to mode 1. Only difference is that homing point detection is not through Z-signal but through triggering of negative limit switch signal

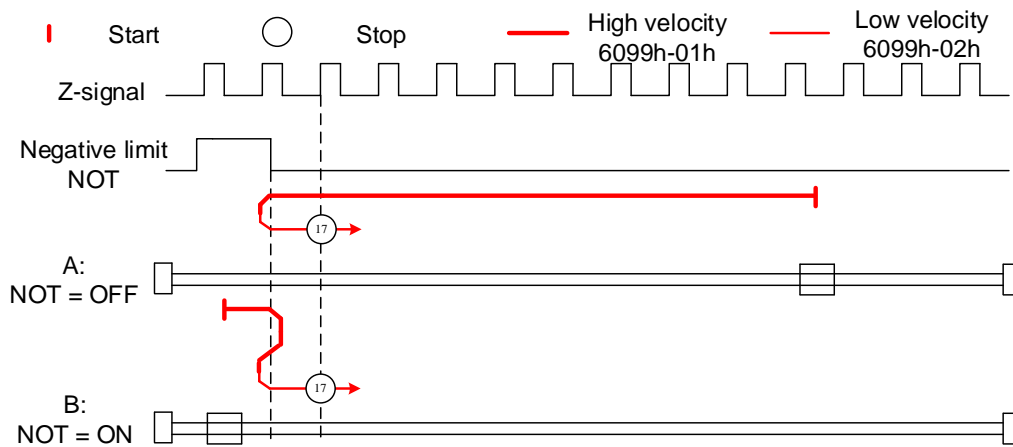

Mode 18:

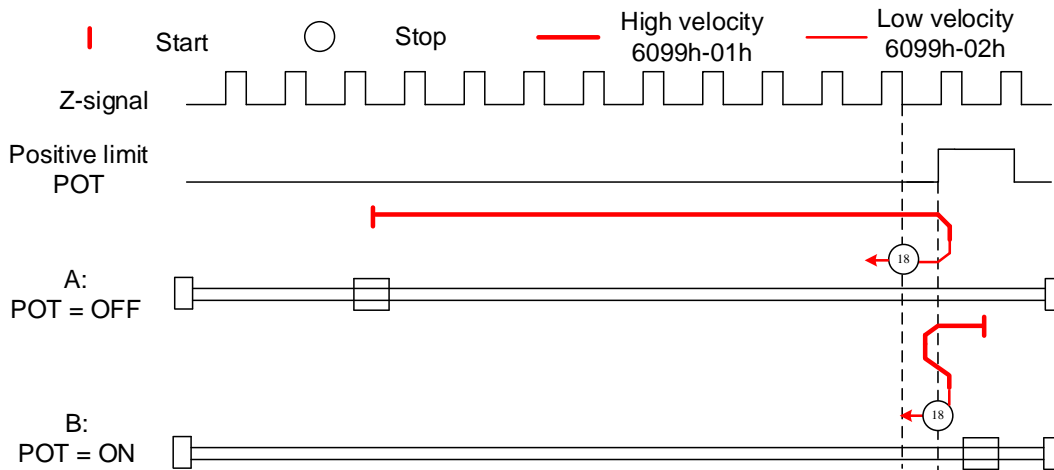
This mode is similar to mode 2. Only difference is that homing point detection is not through Z-signal but through switching of positive limit switch signal

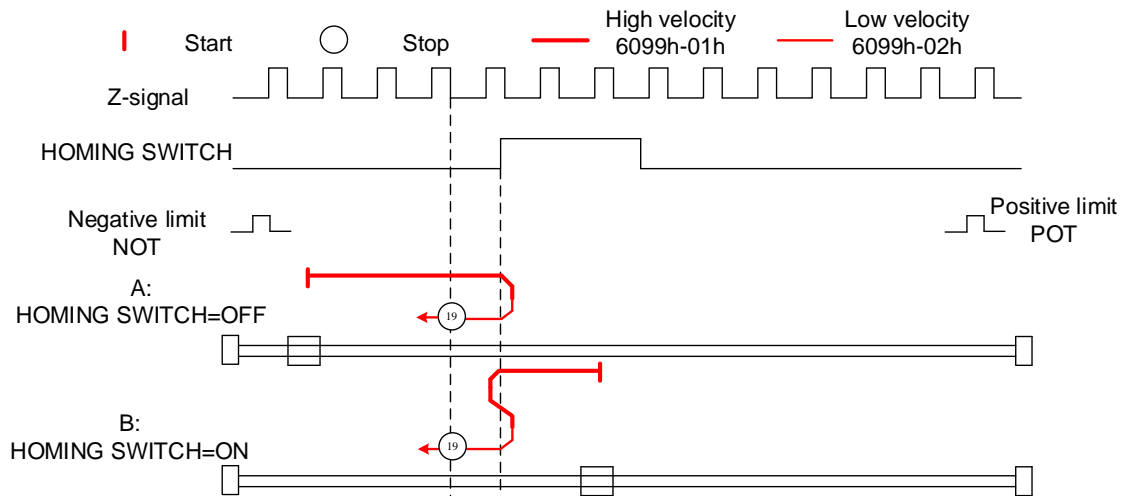

Mode 19:

This mode is similar to mode 3. Only difference is that homing point detection is not through Z-signal but through triggering of homing switch signal

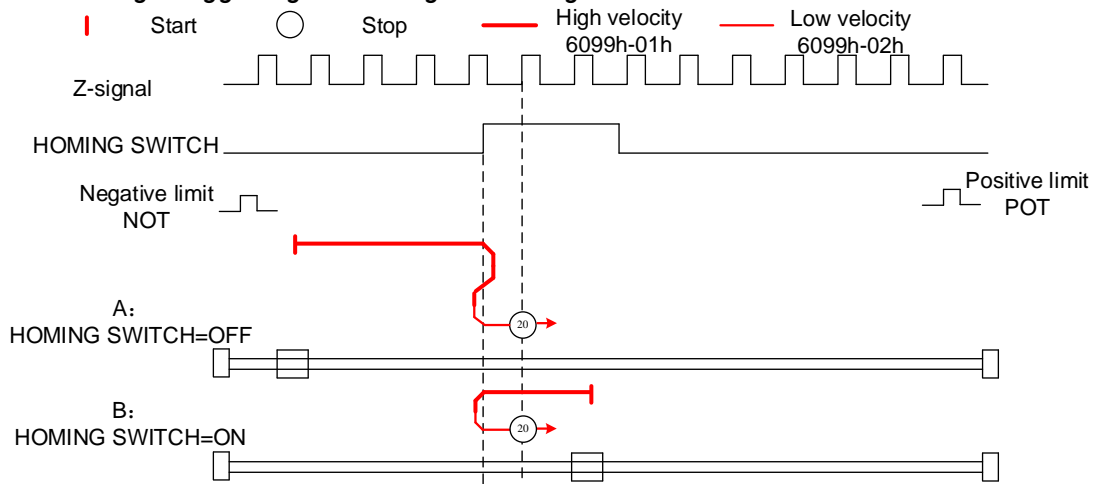

Mode 20:

This mode is similar to mode 4. Only difference is that homing point detection is not through Z-signal but through triggering of homing switch signal

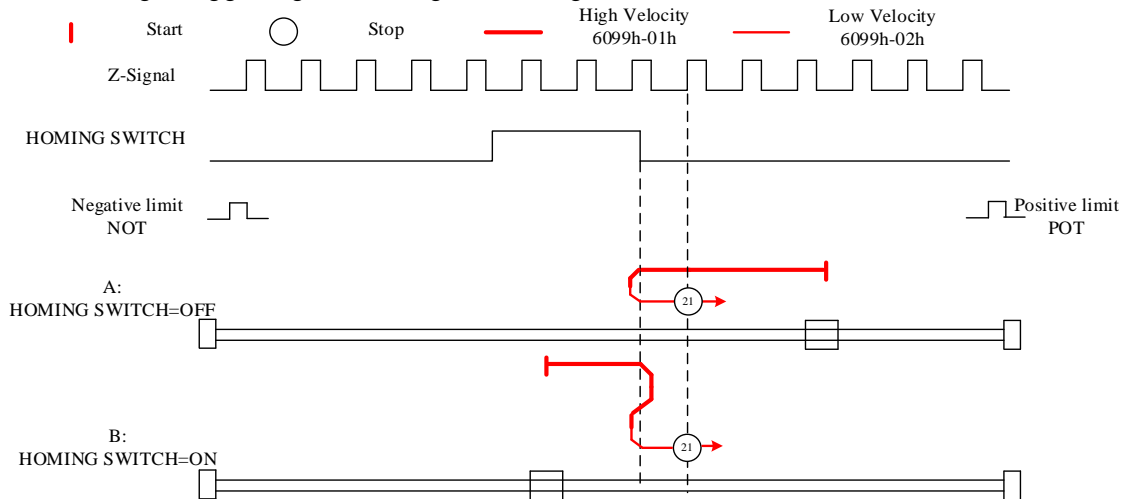

Mode 21:

This mode is similar to mode 5. Only difference is that homing point detection is not through Z-signal but through triggering of homing switch signal.

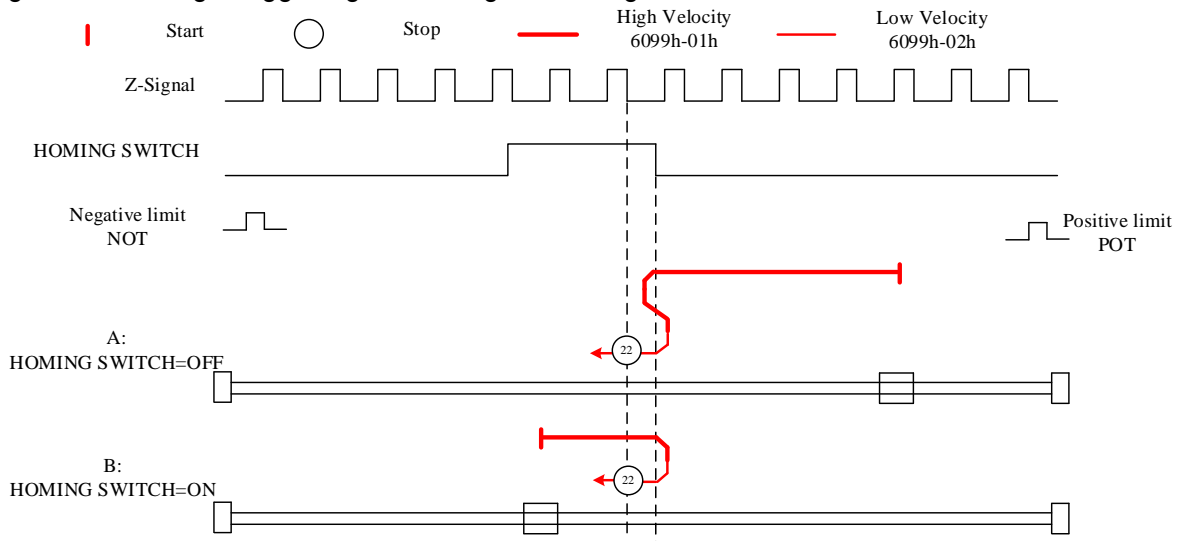

Mode 22:

This mode is similar to mode 6. Only difference is that homing point detection is not through Z-signal but through triggering of homing switch signal.

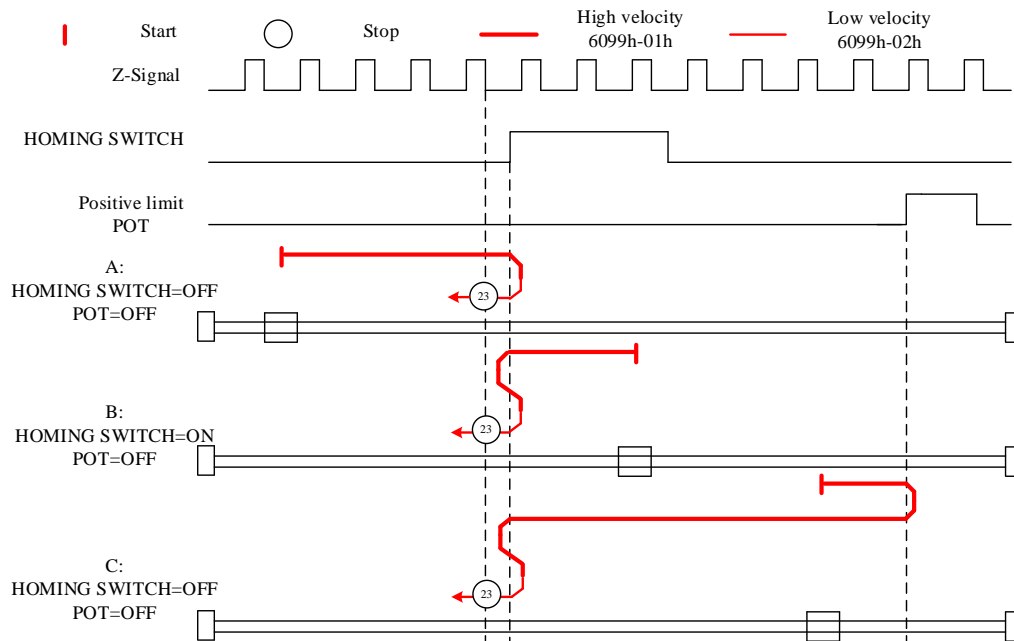

Mode 23:

This mode is similar to mode 7. Only difference is that homing point detection is not through Z-signal but through triggering of homing switch signal.

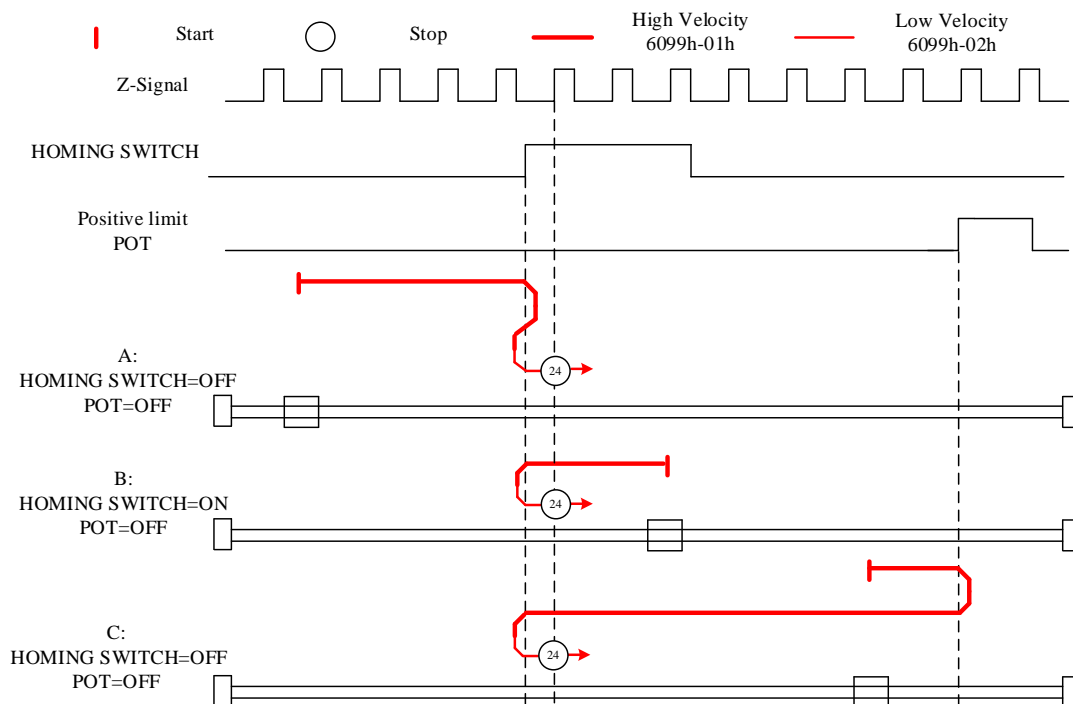

Mode 24:

This mode is similar to mode 8. Only difference is that homing point detection is not through Z-signal but through triggering of homing switch signal.

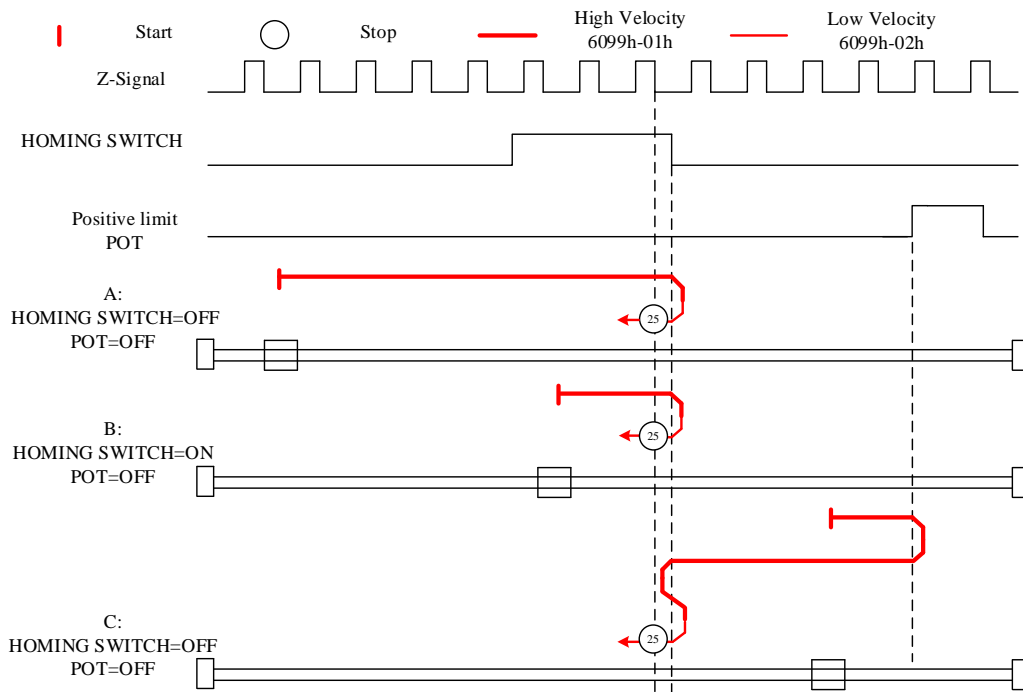

Mode 25:

This mode is similar to mode 9. Only difference is that homing point detection is not through Z-signal but through triggering of homing switch signal

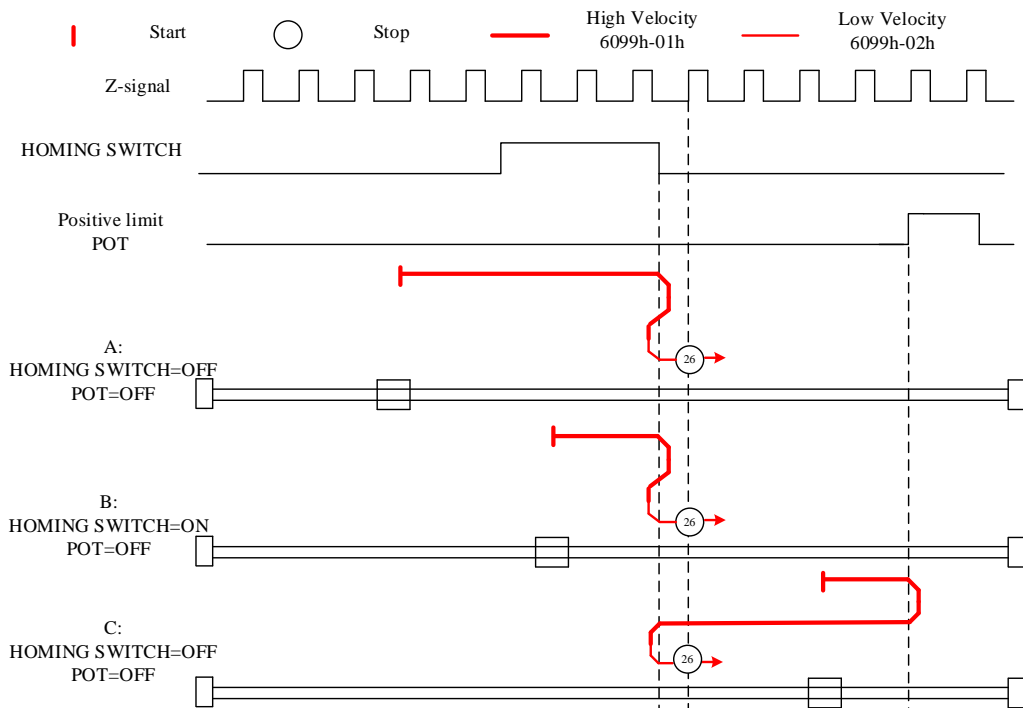

Mode 26:

This mode is similar to mode 10. Only difference is that homing point detection is not through Z-signal but through triggering of homing switch signal

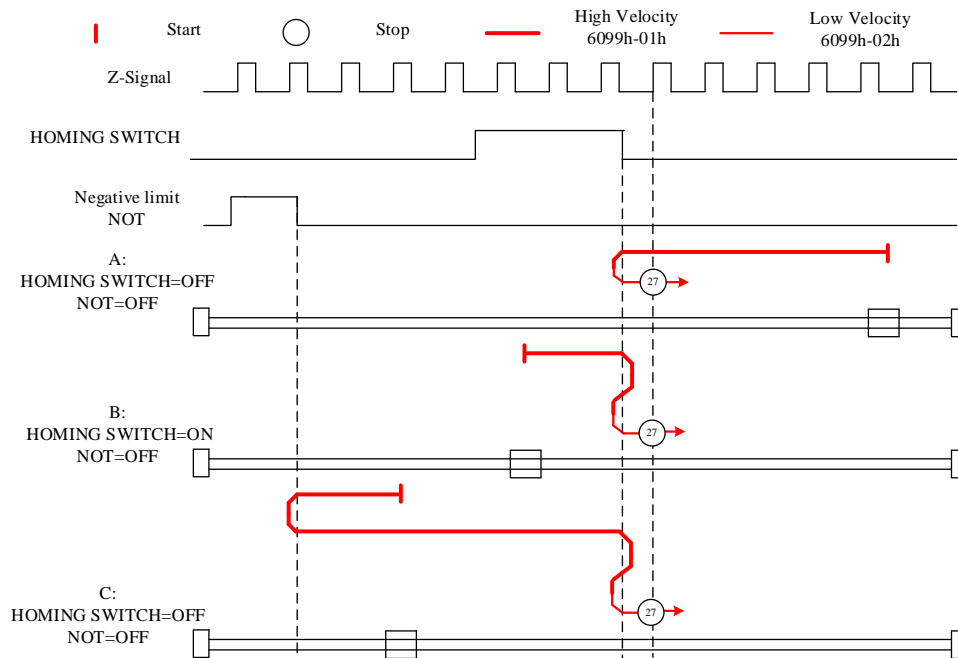

Mode 27:

This mode is similar to mode 11. Only difference is that homing point detection is not through Z-signal but through triggering of homing switch signal

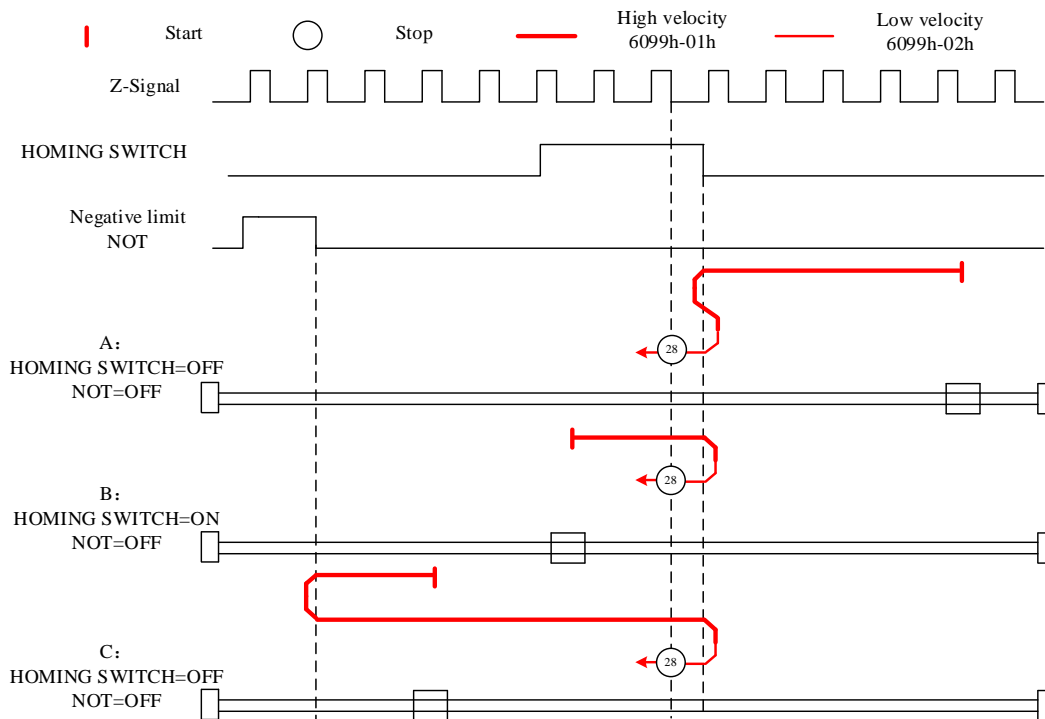

Mode 28:

This mode is similar to mode 12. Only difference is that homing point detection is not through Z-signal but through triggering of homing switch signal

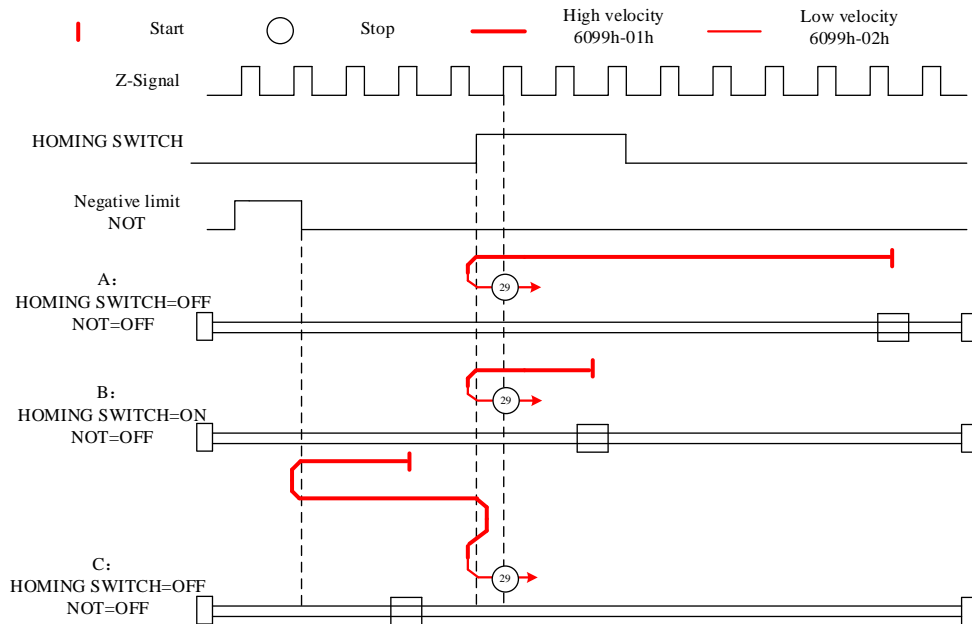

Mode 29:

This mode is similar to mode 13. Only difference is that homing point detection is not through Z-signal but through triggering of homing switch signal

Mode 30:

This mode is similar to mode 14. Only difference is that homing point detection is not through Z-signal but through triggering of homing switch signal

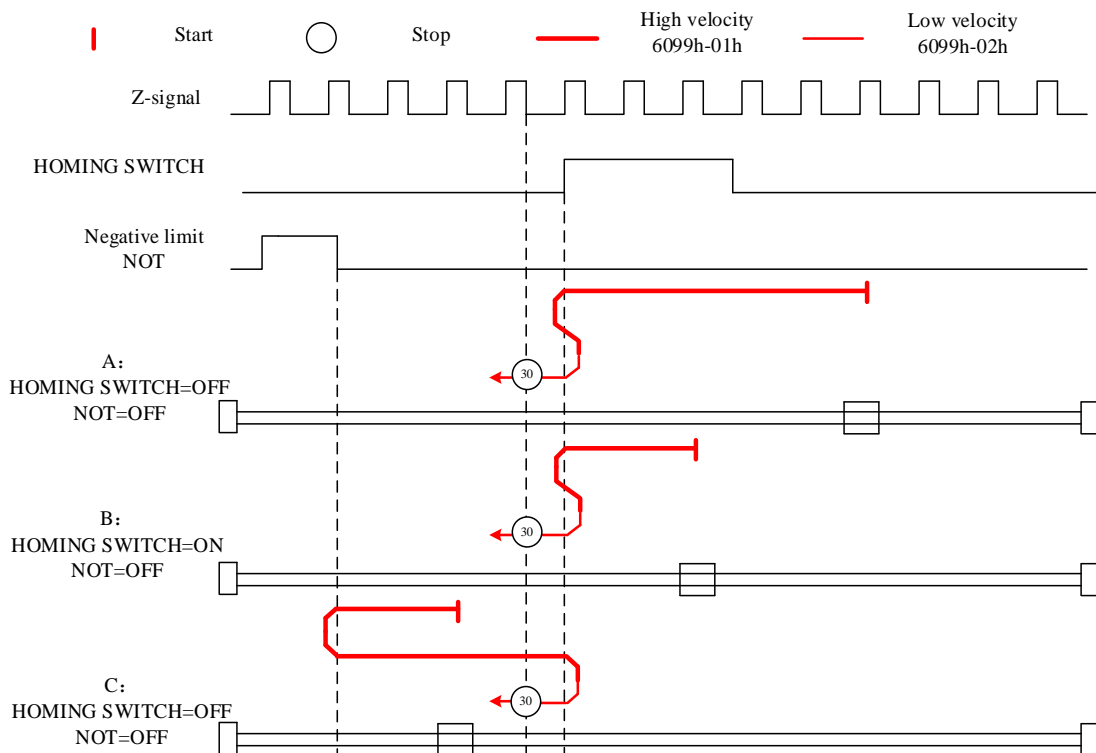

Mode 33:

The motor starts to move in **negative direction** and stops when the **Z-signal** is valid.

If the positive/negative limit switch signal or homing switch is valid during the homing process, the status word (6041h) bit 13 will be valid, indicating homing error and the motor will stop immediately.

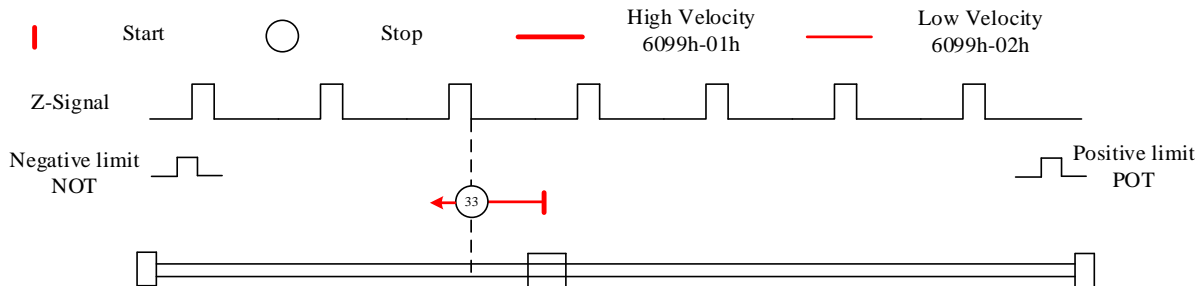

Mode 34:

The motor starts to move in **positive direction** and stops when the **Z-signal** is valid.

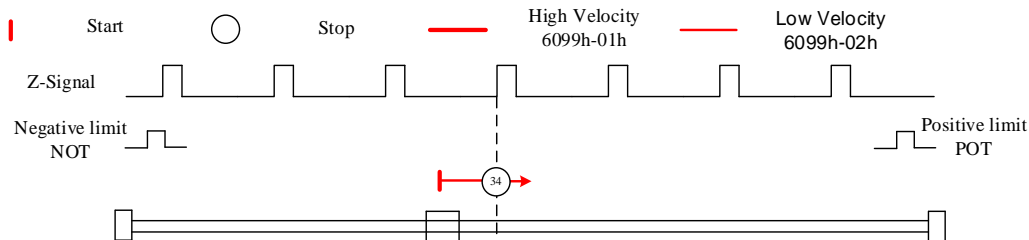
If the positive/negative limit switch signal or homing switch is valid during the homing process, the status word (6041h) bit 13 will be valid, indicating homing error and the motor will stop immediately.

Mode 35/37:

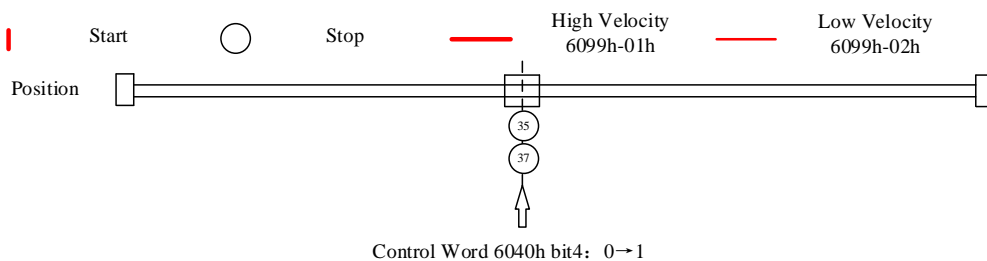
Set the current position as homing point. Using this mode, motor doesn't have to be enabled. Set control word 6040h bit 4 from 0 to 1.



4.5 Emergency Stop

4.5.1 Motion Settings

- Set 6060h = 3 for Profile Velocity mode.
- Set 6040h to corresponding value to machine status and start motion.

No.	Object Dictionary	Label	Set Value	Unit
1	6085h	Emergency stop deceleration	-	pulse/s ²
2	6040h	Control word	As per need	-

4.5.2 Monitoring settings

- To monitor 6041h for motion status

No.	Object Dictionary	Label	Unit
1	6041h	Status word	-

Chapter 5 Applications

5.1 Trial Run

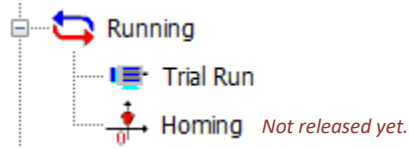

Trial Run

To test run servo products after successfully connected to Motion Studio and initial setup is done. Main power supply and motor/encoder cable need to be connected to use this function.

Trial run
✕

Position

Setting
1

Pr6.04 Jog Speed	300	rpm
Pr6.25 Acceleration of trial running	150	ms/1000rpm
Pr0.04 Inertia ratio	250	

<< Expand

Press enter to modify parameters

Servo Enable

ON

External enabling disabled

Current Position 10.4785 r



Positive direction

Negative direction

Position 1

Position 2

10.4785

10.4785

Pr6.21 Waiting time of trial running 300 ms

Pr6.22 Cycling times of trial running 5

Run

5.2 Inertia Ratio measuring

Inertia measuring using Motion Studio

1. Start Motion Studio and maneuver to inertia ratio identification page under performance tuning. Set trial run velocity Pr6.04 and acc-/deceleration time Pr6.25, click on 'Upload' to upload parameters to servo driver.
2. Tick "Prohibit external enabling" and click on "servo on".
3. Click and hold "CCW" to start the motor. Current position will show motor cycles of revolution. Click on POS 1 to save current position as starting point. Click and hold "CW" to start the motor again. Click on POS 2 to save current position as ending point.
4. Set the waiting time between each cycle in Pr6.21 and no. of cycles in Pr6.22. Click on 'Run' and motor will run according to the parameters set.

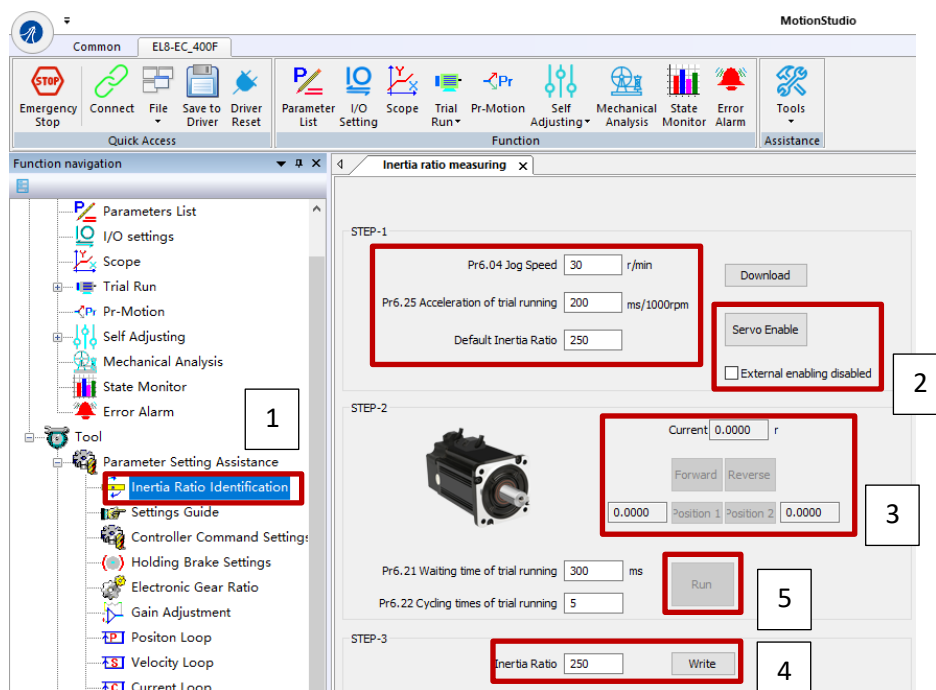

5. After the calculation is done, inertia ratio will be calculated automatically and click on 'write' to enter the calculated value into Pr0.04.

6. Click on “Parameter List” to enter parameters management to check or modify Pr0.04. Then, click on “Save” to save parameters to driver.

Number	Label	AxisA	Min	Max	Defa...	Unit	Enable Mode	Remarks
PA0.00	Model-following bandwi...	1	0	5000	1	0.1Hz	Immediately	Null
PA0.02	Real time Auto Gain Adj...	0x1	0x0	0xFF	0x1	--	Immediately	Null
PA0.03	Real time auto stiffness ...	70	50	81	70	--	Immediately	Null
PA0.04	Inertia ratio	250	0	20000	250	%	Immediately	Null
PA0.06	Command polarity inver...	0	0	1	0	--	Poweroff Res...	Null
PA0.07	Probe signal polarity set...	3	0	3	3	--	Poweroff Res...	Null
PA0.08	Command pulse counts ...	0	0	67108...	0	--	Poweroff Res...	Null
PA0.09	1st command frequency...	1	1	21474...	1	--	Poweroff Res...	Null
PA0.10	Command frequency m...	1	1	21474...	1	--	Poweroff Res...	Null
PA0.11	Encoder pulse output pe...	2500	1	32767	2500	P/rev	Poweroff Res...	Null
PA0.12	Pulse output logic inver...	0	0	1	0	--	Poweroff Res...	Null
PA0.13	1st Torque Limit	350	0	500	350	%	Immediately	Null
PA0.14	Excessive Position Devia...	30	0	310	30	0.1rev	Immediately	Encoder unit
PA0.15	Absolute Encoder settings	0	0	32767	0	--	Poweroff Res...	Null
PA0.16	Regenerative resistance	100	25	500	100	Ohm	Immediately	Null
PA0.17	Regenerative resistor po...	50	20	5000	50	W	Immediately	Null
PA0.19	Friction compensation s...	0	0	1000	0	--	Immediately	Null

Please take note:

1. Trial run velocity and distance should be optimal to prevent any axis from bumping into objects.
2. It is recommended to move only in 1 direction for vertically mounted axis. Take precaution before moving the axis.
3. For applications with higher frictional drag, please set a minimal travel distance.

Pr0.04	Label	Inertia ratio		Mode						F
	Range	0~20000	Unit	%	Default	250	Index		2004h	
	Activation	Immediate								

$$\text{Pr0.04} = (\text{load inertia} / \text{motor rotational inertia}) \times 100\%$$

Notice:

Set inertia ratio according to actual load inertia. When both are uniform, actual motor velocity loop responsiveness and gain settings will be consistent. If inertia ratio is greater than actual value, velocity loop gain settings will be higher and vice versa.

Common issues

Error	Cause	Solution
Inertia measuring failure	Loose load connection	Check for mechanical failure
	Measuring distance is too short	Increase measuring distance
	Belt load	Please pre-set an inertia ratio when using a belt to prevent jolt due to low inertia.

5.3 Notch Filter (Vibration Suppression)

To use notch filter

Automatic notch filter

1. Set Pr2.00 = 1 for auto notch filter adjustment
2. If Pr0.03 stiffness increases, 3rd group of notch filter (Pr2.07/Pr2.08/Pr2.09) updates automatically when driver is enabled. Pr2.00 = 0, auto adjustments stop.
If resonance is suppressed, it means self-adjusting notch filter is working. If resonance occurs when mechanical stiffness increases, please use manual notch filter, set filter frequency to actual resonant frequency.

Manual notch filter

There are 2 ways to use manual notch filter.

1. After enabling self-adjusting notch filter, set the values from 3rd group of filters to 1st group of notch filter (Pr2.01/Pr2.02/Pr2.03), see if resonance is suppressed. If there is other resonance, set Pr2.00 = 1, then set the values from 3rd group of filters to 2nd group of notch filter (Pr2.04/Pr2.05/Pr2.06)

Get resonant frequency, notch filter bandwidth and depth and set it into the corresponding parameters through Motion Studio

Pr2.00	Label	Adaptive filtering mode settings			Mode						F															
	Range	0~4	Unit	-	Default	0	Index	2200h																		
	Activation	Immediate																								
<table border="1" style="width: 100%; border-collapse: collapse;"> <thead> <tr> <th style="width: 15%;">Set value</th> <th colspan="2">Explanation</th> </tr> </thead> <tbody> <tr> <td style="text-align: center;">0</td> <td>Adaptive filter: invalid</td> <td>Parameters related to 3rd and 4th notch filter remain unchanged</td> </tr> <tr> <td style="text-align: center;">1</td> <td>Adaptive filter: 1 filter valid for once.</td> <td>1 adaptive filter becomes valid. 3rd notch filter related parameters updated accordingly. Pr2.00 switches automatically to 0 once updated.</td> </tr> <tr> <td style="text-align: center;">2</td> <td>Adaptive filter: 1 filter remains valid</td> <td>1 adaptive filter becomes valid. 3rd notch filter related parameters will keep updating accordingly.</td> </tr> <tr> <td style="text-align: center;">3-4</td> <td>Reserved</td> <td>-</td> </tr> </tbody> </table>												Set value	Explanation		0	Adaptive filter: invalid	Parameters related to 3 rd and 4 th notch filter remain unchanged	1	Adaptive filter: 1 filter valid for once.	1 adaptive filter becomes valid. 3 rd notch filter related parameters updated accordingly. Pr2.00 switches automatically to 0 once updated.	2	Adaptive filter: 1 filter remains valid	1 adaptive filter becomes valid. 3 rd notch filter related parameters will keep updating accordingly.	3-4	Reserved	-
Set value	Explanation																									
0	Adaptive filter: invalid	Parameters related to 3 rd and 4 th notch filter remain unchanged																								
1	Adaptive filter: 1 filter valid for once.	1 adaptive filter becomes valid. 3 rd notch filter related parameters updated accordingly. Pr2.00 switches automatically to 0 once updated.																								
2	Adaptive filter: 1 filter remains valid	1 adaptive filter becomes valid. 3 rd notch filter related parameters will keep updating accordingly.																								
3-4	Reserved	-																								

Pr2.01	Label	1 st notch frequency			Mode						F
	Range	50~4000	Unit	Hz	Default	4000	Index	2201h			
	Activation	Immediate									
Set center frequency of 1 st torque command notch filter. Set Pr2.01 to 4000 to deactivate notch filter											

Pr2.02	Label	1 st notch bandwidth selection			Mode							F
	Range	0~20	Unit	-	Default	4	Index	2202h				
	Activation	Immediate										
Set notch bandwidth for 1 st resonant notch filter. Under normal circumstances, please use factory default settings. If resonance is under control, in combination with Pr2.01 and Pr2.03, Pr2.02 can be reduced to improve current loop responsiveness which allows higher mechanical stiffness settings.												

Pr2.03	Label	1 st notch depth selection			Mode							F
	Range	0~99	Unit	-	Default	0	Index	2203h				
	Activation	Immediate										
Set notch depth for 1 st resonant notch filter. Under normal circumstances, please use factory default settings. If resonance is under control, in combination with Pr2.01 and Pr2.02, Pr2.03 can be reduced to improve current loop responsiveness which allows higher mechanical stiffness settings.												

Pr2.04	Label	2 nd notch frequency			Mode							F
	Range	50~4000	Unit	Hz	Default	4000	Index	2204h				
	Activation	Immediate										
Set center frequency of 2 nd torque command notch filter. Set Pr2.04 to 4000 to deactivate notch filter												

Pr2.05	Label	2 nd notch bandwidth selection			Mode							F
	Range	0~20	Unit	-	Default	4	Index	2205h				
	Activation	Immediate										
Set notch bandwidth for 2 nd resonant notch filter. Under normal circumstances, please use factory default settings. If resonance is under control, in combination with Pr2.04 and Pr2.06, Pr2.05 can be reduced to improve current loop responsiveness which allows higher mechanical stiffness settings.												

Pr2.06	Label	2 nd notch depth selection			Mode							F
	Range	0~99	Unit	-	Default	0	Index	2206h				
	Activation	Immediate										
Set notch depth for 1 st resonant notch filter. When Pr2.06 value is higher, notch depth becomes shallow, phase lag reduces. Under normal circumstances, please use factory default settings. If resonance is under control, in combination with Pr2.04 and Pr2.05, Pr2.06 can be reduced to improve current loop responsiveness which allows higher mechanical stiffness settings.												

Pr2.07	Label	3 rd notch frequency			Mode							F
	Range	50~400 0	Unit	Hz	Default	4000	Index	2207h				
	Activation	Immediate										
Set center frequency of 3 rd torque command notch filter. Set Pr2.07 to 4000 to deactivate notch filter												

Pr2.08	Label	3 rd notch bandwidth selection			Mode							F
	Range	0~20	Unit	-	Default	4	Index	2287h				
	Activation	Immediate										
Set notch bandwidth for 3 rd resonant notch filter. Under normal circumstances, please use factory default settings.												

Pr2.09	Label	3 rd notch depth selection			Mode							F
	Range	0~99	Unit	-	Default	0	Index	2206h				
	Activation	Immediate										
Set notch depth for 1 st resonant notch filter. When Pr2.09 value is higher, notch depth becomes shallow, phase lag reduces.												

5.4 Auto gain adjustment

This function will measure real time mechanical properties and set gain values in accordance to mechanical stiffness. Can be used in any control mode

Conditions to implement	
Control mode	Please refer to Pr0.02 for detailed explanations. Auto gain adjustment is different for each control mode.
Other	<ul style="list-style-type: none"> • Servo driver needs to be enabled • Set up input signals such as deviation counter clearing and command input; Torque limit and other motion control parameters to enable motor to move normally without obstacles.

Under certain conditions, external factors might affect automatic gain adjustment functions. If the conditions as listed exist or unfavorable, please disable the automatic gain adjustment function.

Affecting conditions	
Load inertia	<ul style="list-style-type: none"> • If inertia is less than 3 times or over 20 times of rotor inertia. • Changes in load inertia
Load	<ul style="list-style-type: none"> • Very low mechanical stiffness • If gear backlash is a non-linear property
Motion	<ul style="list-style-type: none"> • Velocity less than 100r/min or continuously in low velocity mode

	<ul style="list-style-type: none"> • Acc-/deceleration to 2000r/min within 1s. ◦ • Acc-/deceleration torque lower than eccentric load, frictional torque. • Velocity < 100r/min, acc-/deceleration to 2000r/min within 1s but not longer than 50ms
--	--

To enable automatic gain adjustment:

1. Disable the servo driver.
2. Set Pr0.02 = 0x01/0x11 or 0x02/0x12. Then, set Pr0.03
3. Servo enabled. Run motion as normal to start measuring load properties. Related parameters will be automatically set.
4. Increase motor responsiveness by increasing Pr0.03. Please check if there is any vibration before setting Pr0.03 to max. value.
5. Save the parameters.

Please take note:

- Please stop the motor before modifying any parameter. Pr0.02 only takes effect after saving modified parameter values into EEPROM and restarting the driver.
- After enabling the servo driver for the first time or when increasing Pr0.03, mechanical noise or vibration might occur for the first run, it is normal. If it persists, please set Pr0.03 to lower value.

Parameters that change in accordance to real time gain adjustment

There are 2 types of auto gain adjustment methods:

- **Standard mode** (Pr0.02 = 1): Basic mode, prioritizing on stability, gain switching is disabled. Actual gain auto adjustment as accordance to Pr0.03.

Gain related parameters that change as shown below.

Parameter	Label	Remarks
Pr1.00	1 st position loop gain	When stiffness setting is valid, parameters will be updated to match stiffness value
Pr1.01	1 st velocity loop gain	
Pr1.02	1 st velocity integral time constant	
Pr1.03	1 st velocity detection filter	
Pr1.04	1 st torque filter	

Gain related that doesn't change

Parameter	Label	Reference value	Remarks
Pr1.10	Velocity feedforward gain constant	300 (0.1%)	Doesn't change according to changes in stiffness

- Positioning mode (Pr0.02 = 2): Prioritizing positioning. Usually applies on horizontal axis without variable load, ball screws with lower friction, gain switching enabled. Stiffness level of 2nd position loop gain is 1 level higher than 1st position.

No.	Parameters	Label	Remarks
1	Pr1.00	1 st position loop gain	When stiffness setting is valid, parameters will be updated to match stiffness value
2	Pr1.01	1 st velocity loop gain	
3	Pr1.02	1 st velocity integral time constant	

4	Pr1.03	1 st velocity detection filter
5	Pr1.04	1 st torque filter
6	Pr1.05	2 nd position loop gain
7	Pr1.06	2 nd velocity loop gain
8	Pr1.07	2 nd velocity integral time constant
9	Pr1.08	2 nd velocity detection filter
10	Pr1.09	2 nd torque filter

If auto gain adjustment is valid, the parameters listed above can't be manually modified. Only when Pr0.02 = 0, can the gain related parameters be modified manually.

5.5 3rd gain switching

Besides switching between 1st and 2nd gain, a 3rd gain switching is added to set gain at the moment of stopping to reduce positioning time.

Only available under position mode and Pr6.05 ≠ 0, set Pr6.06 for 3rd gain value. When 2nd gain switches to 1st gain, it has to go through 3rd gain, switching time is set in Pr1.19.

Diagram below shows when Pr1.15 = 7.

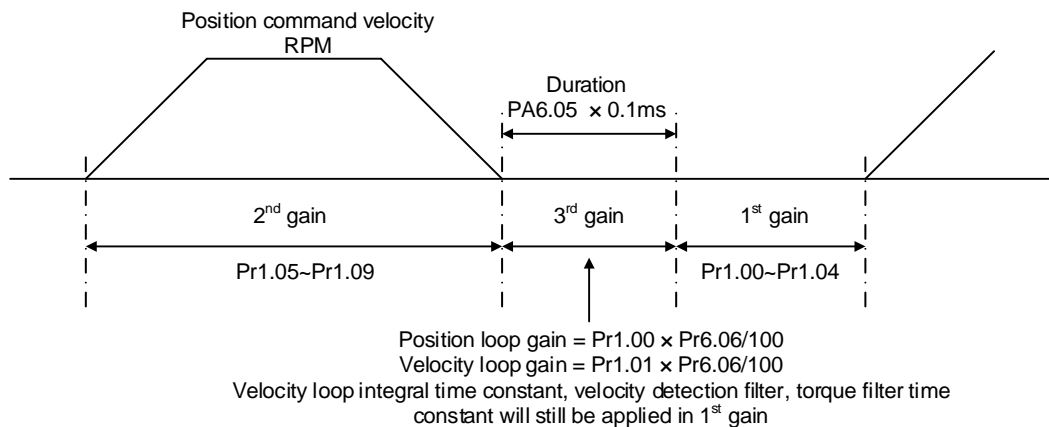

Pr6.05	Label	Position 3 rd gain valid time			Mode	PP		HM		
	Range	0~10000	Unit	0.1ms	Default	0	Index		2605h	
	Activation	Immediate								
To set time for 3 rd gain to be valid When not in use, set Pr6.05=0, Pr6.06=100										
Pr6.06	Label	Position 3 rd gain scale factor			Mode	PP		HM		
	Range	0~1000	Unit	100%	Default	100	Index		2606h	
	Activation	Immediate								

Set up the 3rd gain by multiplying factor of the 1st gain

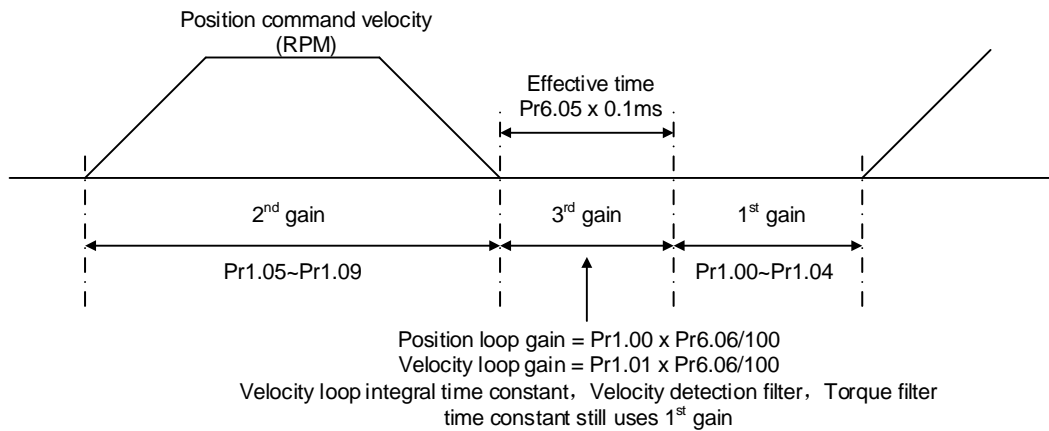

$$3^{\text{rd}} \text{ gain} = 1^{\text{st}} \text{ gain} * \text{Pr6.06}/100$$

Only effective under position control mode, set Pr6.05 \neq 0, 3rd gain function activated, set 3rd gain value in Pr6.06. When 2nd gain switches to 1st gain, will go through 3rd, switching time value set in Pr1.19.

Above diagram is illustrated using Pr1.15 = 7.

5.6 Friction compensation function

This function is to compensation for changes in load to reduce the effect of friction in motion. The compensation value is directional.

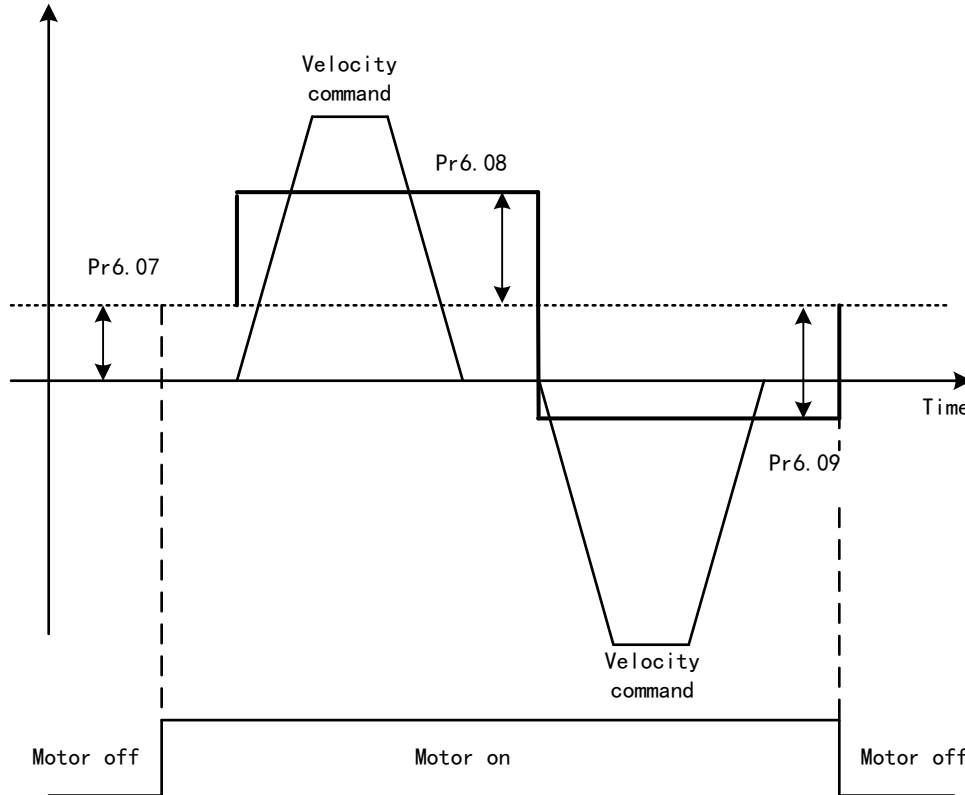

Vertically loaded axis: A constant eccentric load torque is applied on the motor. By adjusting Pr6.07, positioning deviation due to different motional direction can be reduced.

Belt-driven axis: Due to large radial load with dynamic frictional torque. Positioning time delay and deviation can be reduced by adjusting Pr6.08 and Pr6.09.

Pr6.07	Label	Torque command additional value			Mode							F
	Range	-100~100	Unit	%	Default	0	Index	2607h				
	Activation	Immediate										
	To set torque forward feed additional value of vertical axis. Applicable for loaded vertical axis, compensate constant torque. Application: When load move along vertical axis, pick any point from the whole motion and stop the load at that particular point with motor enabled but not rotating. Record output torque value from d04, use that value as torque command additional value (compensation value)											
Pr6.08	Label	Positive direction torque compensation value			Mode							F
	Range	-100~100	Unit	%	Default	0	Index	2608h				
	Activation	Immediate										

Pr6.09	Label	Negative direction torque compensation value			Mode						F
	Range	-100~100	Unit	%	Default	0	Index	2609h			
	Activation	Immediate									

To reduce the effect of mechanical friction in the movement(s) of the axis. Compensation values can be set according to needs for both rotational directions.

Applications:

1. When motor is at constant speed, d04 will deliver torque values.
 Torque value in positive direction = T1;
 Torque value in negative direction = T2

$$\text{Pr6.08/Pr6.09} = T_f = \frac{|T1 - T2|}{2}$$

5.7 Regenerative resistor settings

When motor torque is acting the opposite direction of the rotational direction (i.e. Deceleration, vertical drop axis), energy will flow back into the drive. This will caused the capacitors inside the drive to increase in voltage which might cause over capacity. Regenerative resistor is required here to prevent over capacity of the capacitors.

Regenerative energy can be reduced by reducing rotational inertia, increasing deceleration time, decrease load torque or reduce max. rotational velocity.

Pr0.16	Label	Regenerative resistance			Mode						F
	Range	40~500	Unit	Ohm	Default	100	Index	2016h			
	Activation	Immediate									

To set resistance value of regenerative resistor

Pr0.17	Label	Regenerative resistor power rating			Mode						F
	Range	20~500 0	Unit	W	Default	50	Index	2017h			
	Activation	Immediate									

To set power rating of regenerative resistor.
 Pr0.16 and Pr0.17 determines the threshold value of Er 120. Please set accordingly or it might trigger false alarm or damage to servo driver.
Note: If external regenerative resistor is used, please set according to its labeled power rating.

5.8 Safety Functions

5.8.1 Max. motor rotational speed limitation

Pr3.24	Label	Maximum motor rotational velocity			Mode						F
	Range	0~10000	Unit	r/min	Default	0	Index	2324h			
	Activation	Immediate									
Maximum motor rotational as accordance to technical specification if set to 0											

5.8.2 Max. duration for motor to stop after disabling

Set max time duration for motor to stop after disabling. If the time taken for motor to stop exceeds the duration set in Pr6.14 and motor speed is still higher than Pr4.39, holding brake will be activated. If motor doesn't have holding brake, dynamic braking will be activated to force stop the motor.

Pr6.14	Label	Max. time to stop after disabling			Mode						F
	Range	0~3000	Unit	ms	Default	500	Index	2614h			
	Activation	Immediate									
<p>To set the max. time allowed for the axis to stop on emergency stop or normal axis disabling.</p> <p>After disabling axis, if motor speed is still higher than Pr4.39 but the time set in Pr6.14 is reached, BRK_ON given and holding brake activated.</p> <p>BRK_ON given time is determined by Pr6.14 or when motor speed goes below Pr4.39, whichever comes first.</p> <p>Applications:</p> <ol style="list-style-type: none"> 1. After disabling axis, if motor speed is still higher than Pr4.39 but the time set in Pr6.14 is reached, BRK_ON given and holding brake activated. 2. After disabling axis, if motor speed is already lower than Pr4.39 but the time set in Pr6.14 is not yet reached, BRK_ON given and holding brake activated. 											

5.8.3 External brake deactivation output signal BRK-OFF

Please refer to Pr4.11 to set up the I/O output function parameters. When enabled and timing conditions are fulfilled, the set I/O output will deliver ON signal.

Pr4.37	Label	Motor power-off delay time			Mode							F
	Range	0~3000	Unit	1ms	Default	100	Index		2437h			
	Activation	Immediate										

To set delay time for holding brake to be activated after motor power off to prevent axis from sliding.

Pr4.38	Label	Delay time for holding brake release			Mode							F
	Range	0~3000	Unit	1ms	Default	0	Index		2438h			
	Activation	Immediate										

To set delay time for holding brake to be released after motor power on. Motor will remain at current position and input command is masked to allow holding brake to be fully released before motor is set in motion.

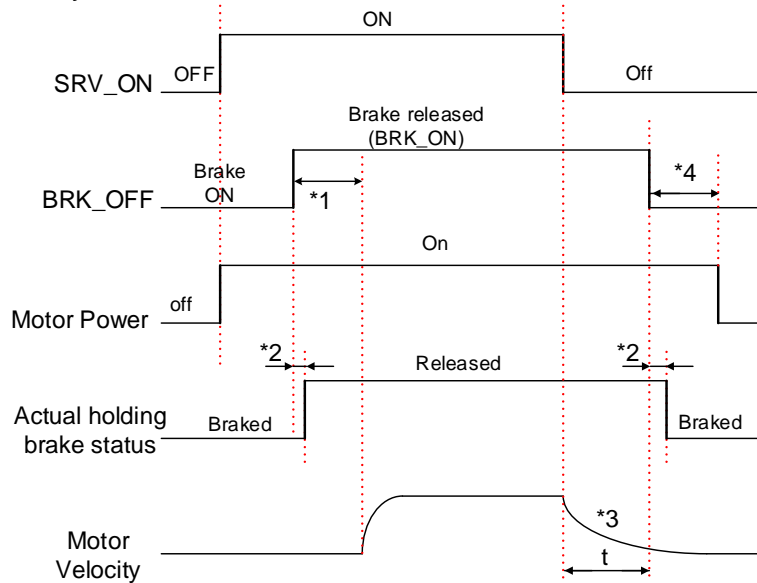

*1: Delay time set in Pr4.38

*2: Delay time from the moment BRK_OFF signal is given until actual holding brake is released or BRK_ON signal is given until actual holding brake is activated. It is dependent on the holding brake of the motor.

*3: Deceleration time is determined by Pr6.14 or if motor speed goes below Pr4.39, whichever comes first. BRK_OFF given after deceleration time.

*4: Pr4.37 set time value.

Delay time from the moment SRV_ON is given until BRK_OFF switch to BRK_ON, is less than 500ms.

Pr4.39	Label	Holding brake activation speed			Mode							F
	Range	30~3000	Unit	RPM	Default	30	Index	2439h				
	Activation	Immediate										

To set the activation speed for which holding brake will be activated.

When SRV-OFF signal is given, motor decelerates, after it reaches below Pr4.39 and Pr6.14 is not yet reached, BRK_OFF is given.
BRK_OFF signal is determined by Pr6.14 or if motor speed goes below Pr4.39, whichever comes first.

Application:

1. After disabling axis, Pr6.14 has been reached but motor speed is still above Pr4.39, BRK_OFF signal given.
2. After disabling axis, Pr6.14 has not been reached but motor speed is below Pr4.39, BRK_OFF signal given.

5.8.4 Servo stopping mode

Pr5.06	Label	Servo-off mode			Mode							F
	Range	0~5	Unit	—	Default	0	Index	2506h				
	Activation	After restart										

To set servo driver disable mode and status.

Set value	Explanation
0	Driver disables after velocity reaching value set in Pr4.39
1	Driver disables immediately, axis in free stopping mode

Pr5.10	Label	Dynamic braking mode			Mode							F
	Range	0~2	Unit	—	Default	0	Index	2510h				
	Activation	After restart										

Set value	Explanation
0	Holding brake valid under normal and abnormal circumstances
1	Holding brake valid only under normal circumstance. To prevent damage to holding brake due to high velocity, large inertia under abnormal circumstances)
2	Holding brake invalid under normal and abnormal circumstances.

5.8.5 Emergency stop function

Emergency stop is used when an alarm occurs or a servo prohibition signal is received when servo driver is enabled.

Method 1: Set up Pr4.43 to enable the function

Pr4.43	Label	Emergency stop function			Mode						F								
	Range	0~1	Unit	-	Default	0	Index	2443h											
	Activation	Immediate																	
0: Emergency stop is valid, servo driver will be forced to STOP and alarm occurs. 1: Emergency stop is invalid, servo driver will not be forced to STOP.																			
Pr5.04	Label	Driver prohibition input settings			Mode						F								
	Range	0~2	Unit	—	Default	0	Index	2504h											
	Activation	Immediate																	
To set driver prohibition input (POT/NOT): If set to 1, no effect on homing mode.																			
<table border="1" style="width: 100%; border-collapse: collapse;"> <thead> <tr style="background-color: #D9E1F2;"> <th style="width: 15%;">Set value</th> <th>Explanation</th> </tr> </thead> <tbody> <tr> <td style="text-align: center;">0</td> <td>POT → Positive direction drive prohibited NOT → Negative direction drive prohibited</td> </tr> <tr> <td style="text-align: center;">1</td> <td>POT and NOT invalid</td> </tr> <tr> <td style="text-align: center;">2</td> <td>Any single sided input from POT or NOT might cause Er260</td> </tr> </tbody> </table>												Set value	Explanation	0	POT → Positive direction drive prohibited NOT → Negative direction drive prohibited	1	POT and NOT invalid	2	Any single sided input from POT or NOT might cause Er260
Set value	Explanation																		
0	POT → Positive direction drive prohibited NOT → Negative direction drive prohibited																		
1	POT and NOT invalid																		
2	Any single sided input from POT or NOT might cause Er260																		
In homing mode, POT/NOT invalid, please set object dictionary 5012-04 bit0=1																			

Method 2: Using 605Ah object dictionary through master device to activate this function.

Pr5.11	Label	Servo braking torque setting			Mode						F
	Range	0~500	Unit	%	Default	0	Index	2511h			
	Activation	Immediate									
To set torque limit for servo braking mode. If Pr5.11 = 0, use torque limit as under normal situation. Between max. torque 6072 and Pr5.11, actual torque limit will take smaller value.											

5.9 Multiturn Absolute encoder

Multiturn absolute encoder records the position and the revolution counts of the motor. When driver is powered-off, multiturn absolute encoder will backed up the data using battery and after powering on, the data will be used to calculated absolute mechanical position and there is no need for a mechanical homing process. Use widely in robotic arms and CNC machines.

If it is the first time using the encoder, please home the mechanical axis and initialize the absolute position of the encoder to zero. Set up a homing point and only home when there is an alarm. Please stop the axis before reading any position data to prevent inaccuracy.

5.9.1 Parameter settings

Pr0.15	Label	Absolute Encoder settings			Mode	PP	HM		
	Range	0~3276 7	Unit	-	Default	0	Index	2015h	
	Activation	Immediate							
<p>0: Incremental mode: Used as an incremental encoder. Doesn't retain position data on power off. Unlimited travel distance.</p> <p>1: Multiturn linear mode: Used as a multiturn absolute encoder. Retrain position data on power off. For applications with fixed travel distance and no multiturn data overflow.</p> <p>2: Multiturn rotary mode: Used as a multiturn absolute encoder. Retrain position data on power off. Actual data feedback in between 0-(Pr6.63). Unlimited travel distance.</p> <p>3: Single turn absolute mode: Used when travel distance is within 1 revolution of the encoder. Data overflow will trigger alarm.</p> <p>5: Clear multiturn alarm and activate multiturn absolute function. Will switch to multiturn mode once alarm cleared, if remains at 5 after 3s, please solve according to Er153.</p> <p>9: Clear multiturn position, reset multiturn alarm and activate multiturn absolute function. Will switch to multiturn mode once alarm cleared, if remains at 9 after 3s, please solve according to Er153. Please disable axis before setting to 9 and home the axis before using.</p>									

5.9.2 Read absolute position

1、Steps:

- 1) First, select a motor with multiturn absolute encoder, install battery and confirm whether the driver version supports the specific motor;
- 2) Set Pr0.15 = 1. If it is the first time of installation, Err153 will occur because battery is newly installed and position data is invalid. Please home the axis and initialize the absolute position of the encoder to zero.
- 3) When absolute homing point is set and there is no fault with the battery, the alarm will be cleared
- 4) Finally, the user can read the absolute position. Position won't be lost even if the driver is powered off.

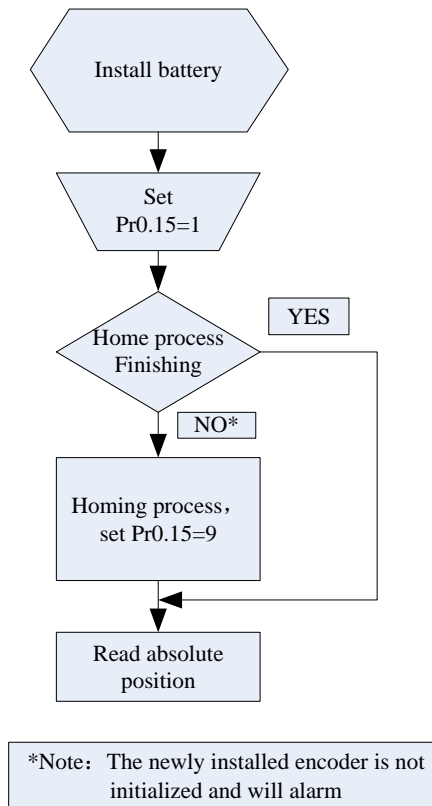

2、Read absolute position

When the rotor turns in clockwise direction, the revolution count will be negative; turns in counter clockwise direction, the count will be positive. No. of revolutions will be from -32767 to +32767. If the count number reaches +32767 in counter clockwise direction, the count will revert back to -32768, -32767 and vice versa for clockwise direction.

As for position data, it depends on the precision of the encoder. For 17 bit = 0-131071, 23 bit = 0-8388607

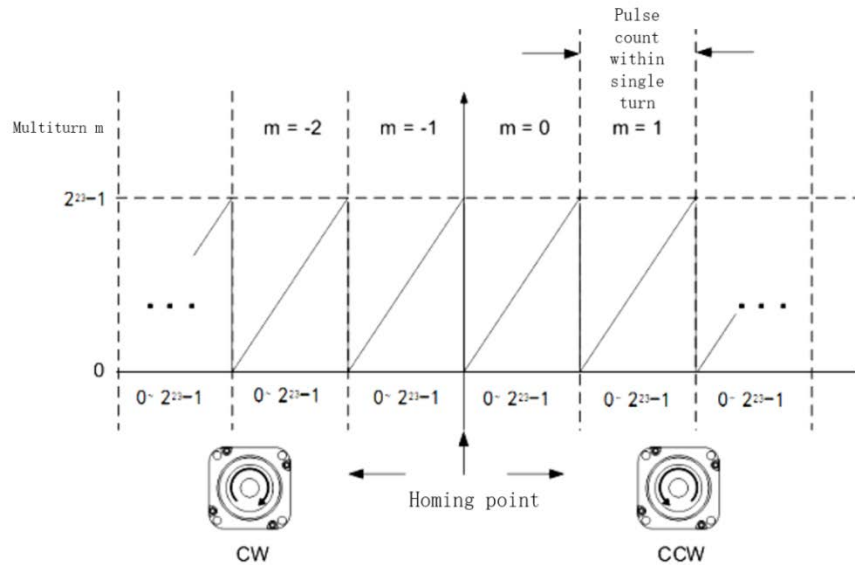

Read data from 6064h object dictionary

Please read data only when the motor is fully stopped or it might cause calculation errors.

Please repeat this step for at least twice to make sure the result is uniform.

3、Clear multiturn position

Before clearing multiturn position, axis needs to be homed. After clearing multiturn position, revolution count = 0 but absolute position remains unchanged and Err153 alarm will be cleared.

Please make sure the homing point is within the range of 1 revolution of the rotor.

Installation and setup of the homing point can be set with the use of auxiliary function D21 on the front panel.

By setting Pr0.15 to 9, multiturn position will be cleared.

Please take notice of motor position during power on. Range of motion of a motor depends on the position of the motor during power on (23-bit absolute encoder as example).

5.9.3 Absolute Encoder Related Alarm

The alarm can determine if absolute value encoder is valid. If battery power is low, not a motor with absolute encoder, encoder error etc. occurs, user can find out about the error from alarm output or on the front panel. Controller will stop any operation until alarm is cleared.

Alarm output:

Err153 will be shown on front panel or by I/O ALM signal and from controller.

Err153 might occur,

- (1) If absolute encoder is used for the first time and due to installation of new batteries Axis needs to be homed and multiturn data needs to be cleared.
- (2) If battery voltage is lower than 3.2v. Replace battery and restart the motor.
- (3) If battery voltage is lower than 2.5v or battery power was cut off. Replacing the battery won't clear the alarm. Axis needs to be homed and multiturn data needs to be cleared.

4、 Alarm processing flow chart

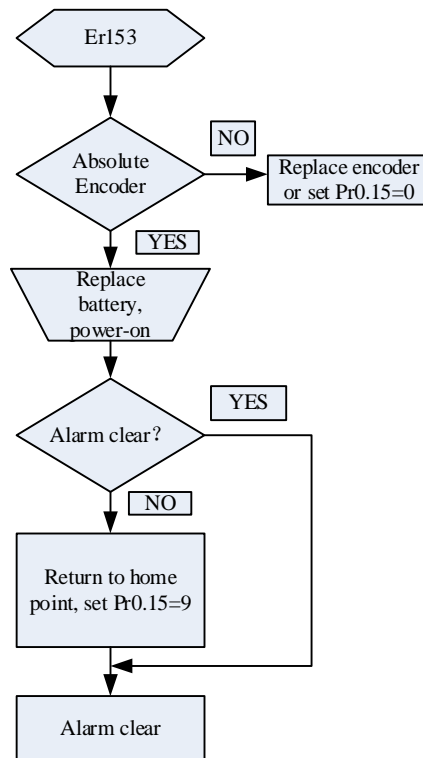

Chapter 6 CANopen Communication

6.1 Communication connection

- RS232 tuning port – Connect to PC tuning software (CN7 for 2nd axis and CN8 for 1st axis)
- RS485 communication – Connect to other drives or master device (CN5)

RS485 network of multiple servo drives

If there is a need to connect multiple 2LD2 series servo drives together, it is recommended to connect the drivers in series and no longer than 3 meters of CABLE-TX*M*-LD2 between each nodes (drivers) as shown below.

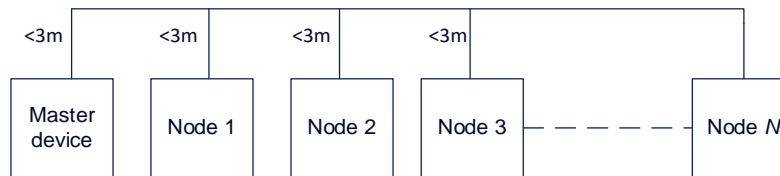

- Keep the connection cable between each node as short as possible. Not longer than 3m.
- Please use shielded twisted pair connection cables.
- Connect to reference ground of the driver.
- Connect shielded foil of the cables to Protective Earth PE terminal.
- Please separate them from power cable or any cable with strong interference.

6.2 CANopen communication parameters and ports

Communication parameters

1. Switch SW to modify Baud rate and terminal resistor. Please refer to the table below.

	Diagram	CAN_ID (High Bit)	SW1	SW2	Baud rate	SW3	SW4	SW5	Terminal resistor	SW6
SW	6	0	OFF	OFF	Pr0.24 Default: 1MHz	OFF	OFF	Reserved	Disconnect ed (CAN)	OFF
					500kHz	ON	OFF			
	1	1	ON	ON	250kHz	OFF	ON		Connected (CAN)	ON
					125kHz	ON	ON			

2. ID spin dial

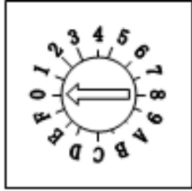
	Diagram	Bit	CAN address	Bit	CAN address
RCS		0	Pr0.23 Default : 16	8	8
		1	1	9	9
		2	2	A	10
		3	3	B	11
		4	4	C	12
		5	5	D	13
		6	6	E	14
		7	7	F	15

Communication Port

To be connected to other drives or master device (controller) – CN5

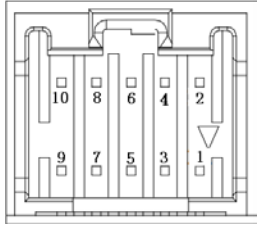
Port	Diagram	Pin	Signal	Label
CN5		1	CANH	CANopen H terminal
		3	CANL	CANopen L terminal
		5	GND	Power supply ground
		Others	NC	10 pins are not applicable

Note:

- Molex 55959-1030 Connector Header (Driver side)
- Molex 51353-1000 10-pin rectangle connector 1pcs for each axis (Provided)
- Molex 56134-9000 female terminal reel 10pcs for each axis (Provided)

6.3 CANopen communication protocol

CANopen communication protocol standards for 2LD2-CAN

- CAN 2.0A standard
- CANopen standard protocol DS301 V4.02
- CANopen standard protocol DSP402 V2.01

CANopen services supported on 2LD2-CAN series

- NMTslave
- Device monitoring services: Heartbeat, node guarding
- PDO: every slave station can be configured with max. of 4 TxPDO and 4 RxPDO
- PDO delivery: Event trigger, time trigger, synchronous cycle, synchronous non-cycle
- SDO
- Emergency Protocol

6.4 Predefined Connections

To reduce networking on CANopen drives, CANopen defines regulatory CAN-ID allocation table. CAN-ID is applicable under Per-Op mode, can modify through dynamic allocation. Corresponding CAN-ID has to be provided by the master device (controller).

CAN-ID allocation table is based on 11 bit CAN-ID, including 4 function bits and 7 Node-ID as shown below.

Function bit				Node-ID						
10	9	8	7	6	5	4	3	2	1	0

Node-ID ranges from 1-127 (0 is not applicable)

Predefined connection includes 4 receiving PDO (RxPDO), 4 transmitting PDO (TxPDO), 1 SDO (2 CAN-ID), 1 urgent object and 1 Node error control ID. Unverified NMT module control service is also supported, SYNC and Time Stamp object broadcast is as table below.

CANopen predefined slave/master connection broadcast object			
Object	Function code	COB-ID	Object dictionary index
NMT module control	0000	0x000	—
SYNC	0001	0x080	1005H,1006H,1007H
Time Stamp	0010	0x100	1012H,1013H
CANopen slave/master connection equal object			
Object	Function code	COB-ID	Object dictionary index
Urgent	0001	0x080+Node-ID	1024H,1015H
TXPDO1(Transmit)	0011	0x180+Node-ID	1800H
RXPDO1(Receive)	0100	0x200+Node-ID	1400H
TXPDO2(Transmit)	0101	0x280+Node-ID	1801H
RXPDO2(Receive)	0110	0x300+Node-ID	1401H

TXPDO3(Transmit)	0111	0x380+Node-ID	1802H
RXPDO3(Receive)	1000	0x400+Node-ID	1402H
TXPDO4(Transmit)	1001	0x480+Node-ID	1803H
RXPDO4(Receive)	1010	0x500+Node-ID	1403H
SDO(Server Transmission)	1011	0x580+Node-ID	1200H
SDO(Client Transmission)	1100	0x600+Node-ID	1200H
NMT error control	1110	0x700+Node-ID	1016H~1017H

Note:

1. PDO/SDO Transmit/Receive is from the perspective of CAN slave node
2. NMT error control includes Node Guarding, Heartbeat and Boot-up protocol.

ID address allocation corresponds to predefined master/slave connections because every equal ID different, hence only 1 master device can be connected to max. of 127 slave stations. 2 slave nodes connected together have no communications.

Example: Slave node no. 4 COB-ID of TxPDO2 : $280h+4 = 284h$

6.5 Object Dictionary

Object dictionary is a sequenced object set; every object uses a 16-bit index to search for address. To be able to request for any bit in the data, 8-bit sub-index is defined. Please refer to the table below.

Index	Object
0000H	Non-applicable
0001H—001FH	Standard data type, such Bool, Integer16 etc.
0020H—003FH	Complex data type, such as PDO communication parameters (PDOCommpar)
0040H—005FH	Manufacturer data type
0060H—007FH	Device profile standard data type
0080H—009FH	Device profile complex data type
00A0H—0FFFH	Reserved
1000H—1FFFH	Communication profile, such as device type, no. of PDO, etc.
2000H—5FFFH	Manufacturer specific profile
6000H—9FFFH	Standard device profile, such as DSP 402 object dictionary
A000H—FFFFH	Reserved

Every node in the CANopen network has an object dictionary that includes device descriptions and its parameters.

Object dictionary of node is described in Electronic Data Sheet EDS which can be regulated as accordingly. Node needs only to be able to provide the object required in object dictionary in optional and configurable function object.

CANopen includes many other profiles:

Communication profile – describes main form of object dictionary and communication profile objects.

Also describes CANopen communication objects. Applicable for all CANopen devices

Device profile - describes functions, label, index/sub-index and data type of an object in object dictionary. The objects have to be write only, read only or read/write. Device profile determines if the object is selectable. If required object is more than is provided in device profile, enough room is left for manufacturer to define specific function object. Communication parameter in device profile is the same for all CANopen devices. Device related in object dictionary is different for different devices.

6.5.2 Object dictionary structure

Basic structure of object dictionary is defined in DS 301 as below

Index	Object	Label	Type	Attribute	Selectable
-------	--------	-------	------	-----------	------------

6.5.3 Object type

“Object” in the table in 8.5.2 for LD2-CAN is as below:

Object	Object code	Description
NULL	0	No data
DOMAIN	2	Mass data, such as operable programs
VAR	7	Variable such as BOOL , INT8
ARRAY	8	Array (Same type of data)
RECORD	9	Record (Different type of data)

6.5.4 Access attribute

Attribute	Description
RW	Read/Write
WO	Write only
RO	Read only
CONST	Constant, Read only

6.6 Network Management (NMT)

NMT provides network managing services which realized through master/slave communication mode.

6.6.1 NMT module control

Only NMT master node can transmit NMT control module telegram, all slave nodes must support NMT module control service, NMT module control doesn't have to answer.

NMT master node \rightleftarrows NMT slave node

COB-ID	Byte 0	Byte 1
0x000	Command word	Node-ID

When Node-ID = 0, all NMT slave nodes will be searched for address. Command word value and NMT relations is as below.

Command word	NMT Services
1(01H)	Activate remote nodes
2(02H)	Deactivate remote nodes
128(80H)	Pre-op
129(81H)	Reset nodes
130(82H)	Reset communication

6.6.2 NMT node guarding

NMT master node can monitor the status of each node through this service. Remote frame transmitted by the master node is as below.

NMT master node \rightleftarrows NMT slave node

COB-ID
0x700+Node-ID

Reply from NMT slave node

NMT slave node \rightleftarrows NMT master node

COB-ID	Byte 0
0x700+Node-ID	Bit 6:0 Status

Data including trigger bit (bit 7) must switch between "1" and "0" during each node guarding. Set as "0" on the first trigger of node guarding. Bit 0 to 6 represents node status.

Bit	Status
0(00H)	Initialize
1(01H)	Not connected
2(02H)	Connected
3(03H)	Ready
4(04H)	Stop
5(05H)	Operation
127(7FH)	Pre-operation

Heartbeat is defined as a node that can be configured as operational duty cycle.

Heartbeat producer \rightleftarrows Consumer

COB-ID	Byte 0
0x700+Node-ID	Status
Status code	Status
0	Boot-up
4	Stop
5	Operation
127	Pre-Op

6.6.3 NMT Boot-up

NMT sends Boot-up telegram from node to NMT master to inform that it has switched from initialization status to Pre-Op status.

NMT slave node \rightleftarrows NMT master node

COB-ID	Byte 0
0x700+Node-ID	0

6.6.4 NMT communication status machine

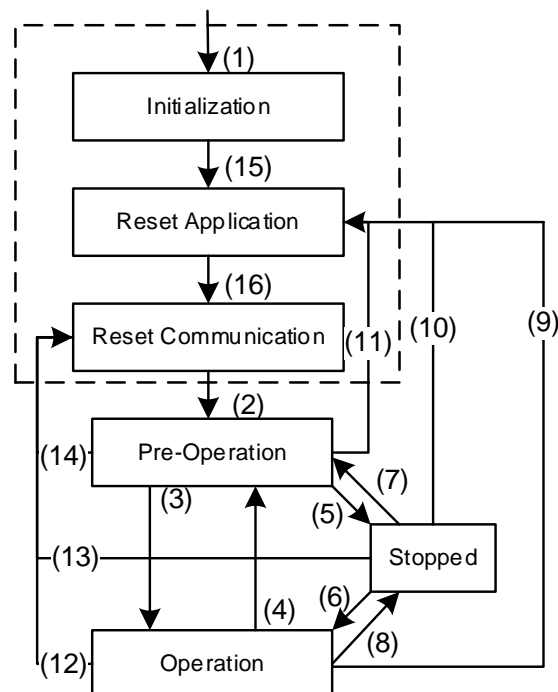

(1) Power on, automatically enter initialization mode.

(2) Enter Pre-Operation mode

(3)(6) Activate remote node

- (4)(7) Enter Pre-Operation mode
- (5)(8) Deactivate remote node
- (9)(10)(11) Reset node
- (12)(13)(14) Reset communication
- (15) Automatically enter reset application mode
- (16) Automatically enter reset communication mode

Enter Pre-Operation after device initialization (Initialization, reset application and reset communication) is done. In this mode, device parameter and ID can be configured using this SDO. Then, node enters directly into operation mode.

6.7 Process Data Object (PDO)

PDO uses producer/consumer mode, PDO data transmission is usually 1-to-1 or 1-to-N. Every PDO message includes transmit PDO (TxPDO) and receive PDO (RxPDO), transmission method is defined using PDO communication parameter index (1st set receive PDO is set in index 1400h, 1st set transmit PDO is set in index 1800h).

All PDO transmission data has to be reflected on corresponding index through object dictionary. Using 1600h and 1A00h object in DSP 402 as example:

Master device sends data to slave station PDO

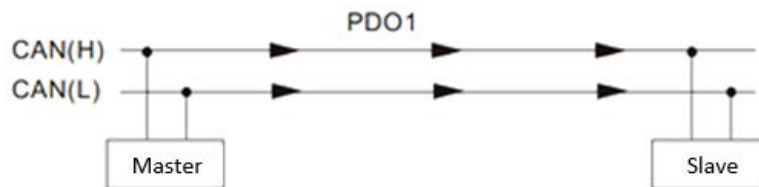

PDO1 data value Data 0, Data 1, Data 2, Data 3, Data 4, Data 5, Data 6, Data 7,
0x11, 0x22, 0x33, 0x44, 0x55, 0x66, 0x77, 0x88,

Index	Sub	Definition	Value	R/W	Size
0x1600	0	0. Number	1	R/W	U8
0x1600	1	1. Mapped Object	0x60400010	R/W	U32
0x1600	2	2. Mapped Object	0	R/W	U32
0x1600	3	3. Mapped Object	0	R/W	U32
0x1600	4	4. Mapped Object	0	R/W	U32
0x6040	0	0. Control word	0x2211	R/W	U16 (2 Byte)

PDO1 Map

0x60400010

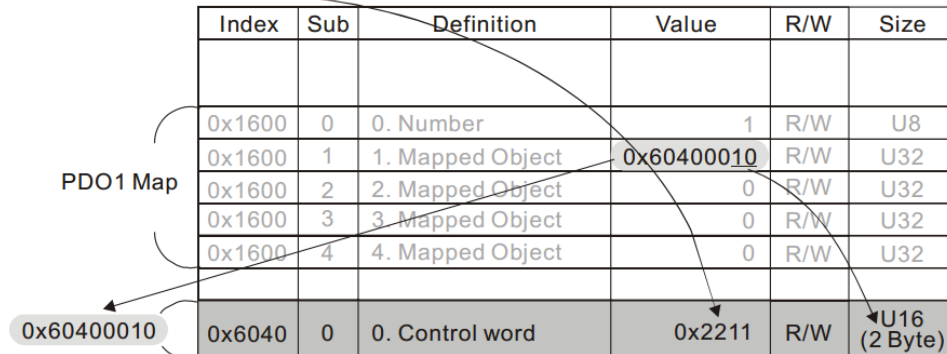

The diagram shows arrows connecting the PDO1 data values to the corresponding rows in the object dictionary table. The value 0x60400010 is highlighted in the table, and an arrow points from it to the '0x60400010' label. Another arrow points from the '0x2211' value in the '0. Control word' row to the '0x2211' value in the PDO1 data list.

Diagram shows in a more detailed description of the relationship between PDO parameters (1400h) and PDO image (1600h), PDO data transmission (Node 2 as example). Arrow represents data flow direction from master device.

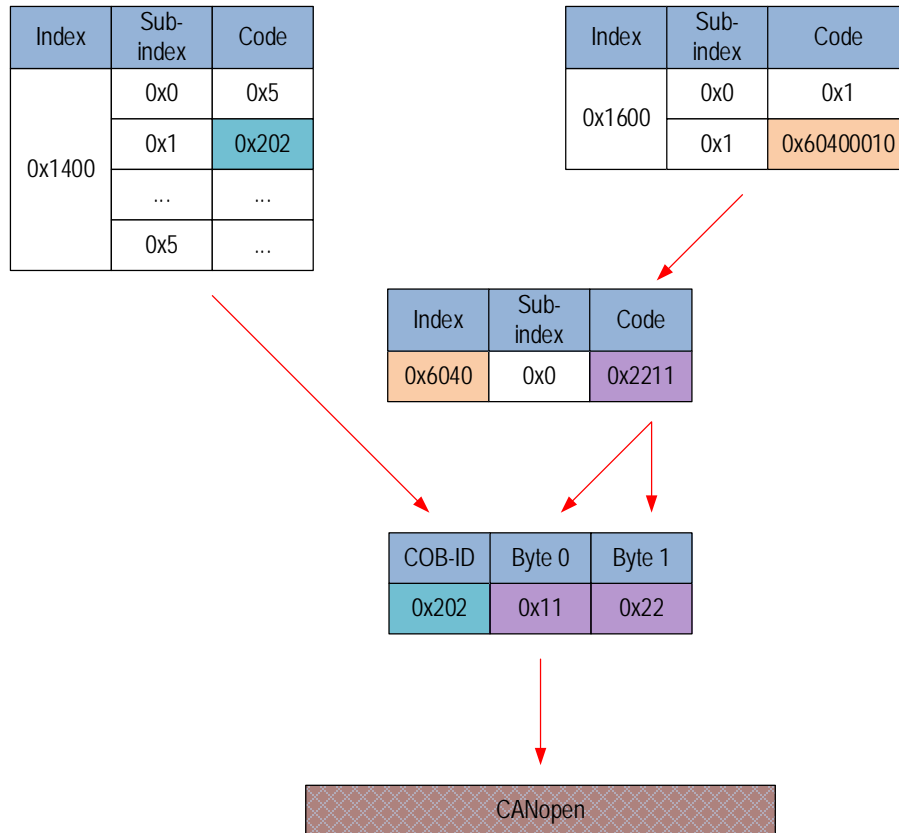

Master device receives data from slave station

PDO1 data value Data 0, Data 1, Data 2, Data 3, Data 4, Data 5, Data 6, Data 7, 0xF3, 0x00,

Index	Sub	Definition	Value	R/W	Size
0x1A00	0	0. Number	1	R/W	U8
0x1A00	1	1. Mapped Object	0x60410010	R/W	U32
0x1A00	2	2. Mapped Object	0	R/W	U32
0x1A00	3	3. Mapped Object	0	R/W	U32
0x1A00	4	4. Mapped Object	0	R/W	U32
0x6041	0	Stalusword	0xF3	R/W	U16

PDO1 Map

Diagram shows in a more detailed description of the relationship between PDO parameters (1800h) and PDO image (1A00h), PDO data transmission (Node 2 as example). Arrow represents data flow direction from slave station.

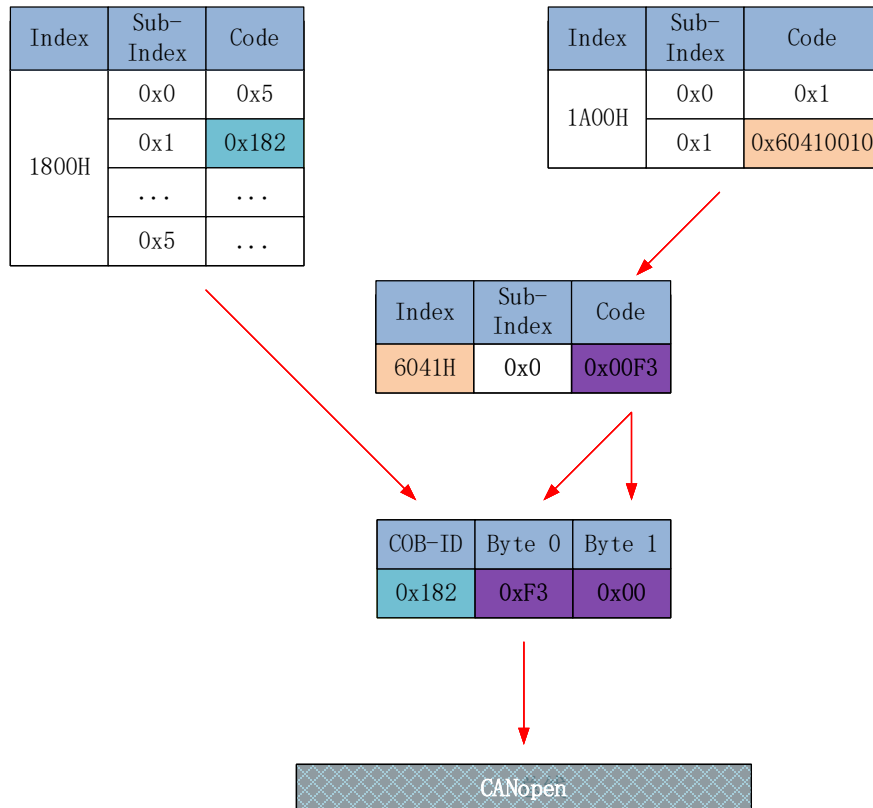

6.8 Service Data Object

SDO is used to access object dictionary of a device. Access side is referred to as client, CANOpen device which provides required services with accessed object dictionary is referred to as server. Clients' CAN telegram and servers' replies CAN telegram includes 8-byte data. Every request from client is met with reply from the server.

Basic structure is as shown below:

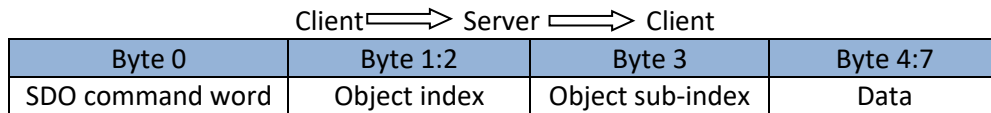

For example, write value 0x20F0 into index 1801h, sub-index 3 with ID no.2 using SDO

Client \rightleftarrows Server

COB-ID	Byte 0	Byte 1	Byte 2	Byte 3	Byte 4	Byte 5	Byte 6	Byte 7
602	2B	01	18	03	F0	20	00	00

Server \rightleftarrows Client

582	60	01	18	03	00	00	00	00
-----	----	----	----	----	----	----	----	----

Using SDO, read object dictionary of index 1801h and sub-index 3 object data.

Client \rightleftarrows Server

COB-ID	Byte 0	Byte 1	Byte 2	Byte 3	Byte 4	Byte 5	Byte 6	Byte 7
602	40	01	18	03	00	00	00	00

Server \rightleftarrows Client

582	4B	01	18	03	F0	20	00	00
-----	----	----	----	----	----	----	----	----

SDO client or server will stop SDO transmission using the telegram format as below

Client \rightleftarrows Server \rightleftarrows Client

Bit	7	6	5	4	3	2	1	0
	1	0	0	-	-	-	-	-

In SDO transmission stop telegram, data byte 0 and 1 represent object index, byte 2 represents sub-index, byte 4-7 include 32-bit stop code, which describes the reason for stopping transmission

6.9 Emergency Object

Emergency object is triggered when there is an occurrence of severe error from device internal. This will be sent to other devices with highest priority. Applicable for alarms which interrupt and stop operation.

An emergency telegram is made up of 8 bytes with format as below:

Transmitting end \rightleftarrows Receiving end

COB-ID	Byte 0:1	Byte 2	Byte 3:7
0x080+Node-ID	Emergency error code	Error registry (1001h)	Manufacturer's specific

Recently appeared error will be stored in object dictionary (index 1003h); user can read these information using; 2LD2 series servo drive will not store these error messages once powered off. Current error type will be stored in object dictionary error registry (index 1001h).

Device can reflect internal error in status word and check for current error type.

Error Registry	Error type
0	General error
1	Current
2	Voltage
3	Temperature
4	Communication
5	Device profile error
6	Reserved
7	Manufacturer's specific error

Chapter 7 Warning and Alarm





7.1 Servo drive alarm overview

Green LED: Power ON/Motor enable

ON for once: Power ON
 Always ON: Motor Enable
 Blinking: Motor Disable
 OFF: Power OFF

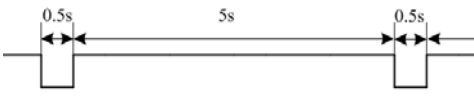
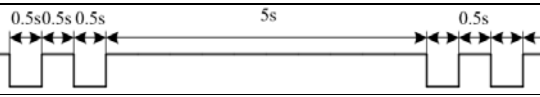
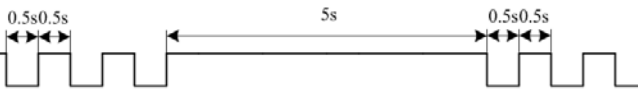
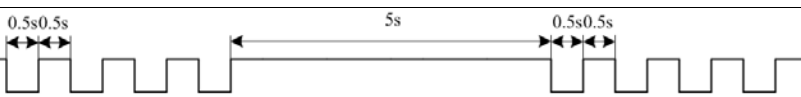
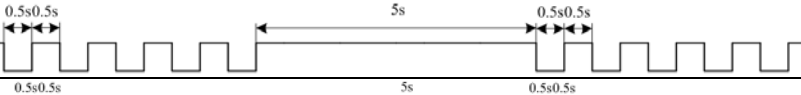
Red LED: Alarm indicator (Motor stops when alarm indicator is ON)

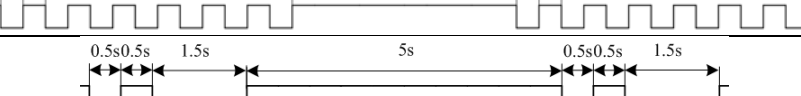
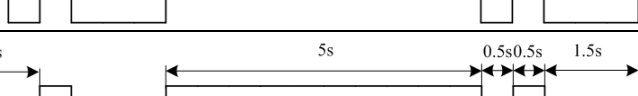
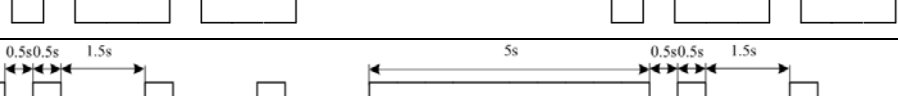
Blink for 5s/cycle (Please refer to the table below)
 OFF: Alarm cleared

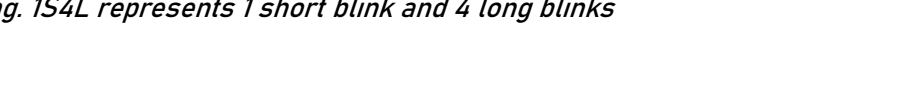
Error	Blink	Sequence	Error
OE1/ OE0	1S		Hardware/software overcurrent
OC0/ OD0	2S		Under-/overvoltage
81B	3S		CANopen communication timeout
OA3	4S		Motor phase missing
150/ 151	5S		Encoder error
100	6S		Overload
180	7S		Excessive position deviation
OF0	8S		Over-temperature
1A0/ 1A1	1S1L		Motor loses speed
OA0/ OA1	1S2L		Hardware initialization error
240	1S3L		Parameter saving error
	1S4L		Other error

S: Short, L: Long. 1S4L represents 1 short blink and 4 long blinks

5202	80	871	Mode not supported under synchronous mode
5441	80	570	IO emergency stop
5510	80	802	RAM full
5511	80	803	RAM over boundary
5530	80	240	EEPROM parameters saving error
5531	80	241	EEPROM hardware error
5532	80	242	Error saving alarm history record
5533	80	243	Error occurred when saving vendor parameters
5534	80	244	Error occurred when saving communication parameters
5535	80	245	Error occurred when saving parameter 402
5536	80	246	Data saving error during power-off
5550	80	850	ESC EEPROM is inaccessible
5551	80	851	ESI file saving error
5552	80	852	Linking failed
FF01	80	860	CANopen frame lost per unit time exceeds limit
6201	80	806	Saved ESI file does not match driver firmware
6202	80	805	FOE firmware update failed
6203	80	814	Firmware invalid
6321	80	210	I/O input configuration repeated
6322	80	211	I/O input parameter out of range
6323	80	212	I/O output parameter out of range
6329	80	090	FPGA parameter writing error
7122	80	5F0	Motor model error
7321	80	150	Encoder disconnected
7322	80	151	Encoder communication error

7323	80	152	Encoder initial position error
7324	80	170	Multiturn encoder error / Encoder parameter settings error
7325	80	153/154	Encoder data overflow
7326	80	155	Encoder overheated
7327	80	156	Encoder count error
7328	80	157	Encoder disconnected
7329	80	260	Position limit alarm, position limit valid during alarm
7701	80	120	Regenerative energy overload
7702	80	121	Regenerative resistor error
8110	10	901	CANopen overload alarm
8120	10	902	Passive error
8130	10	903	Heartbeat/Node guarding timeout
8140	10	904	Disconnection recovered
8141	10	905	Disconnected
8150	10	906	ID clash
8201	10	801	Unknown communication error
8207	10	807	PDO mapping object not exist
8208	10	808	PDO mapping object error
8210	10	82B	Due to length error, PDO not processed /processing timeout
8211	10	818	Due to length error, TPDO not processed /processing timeout
8212	10	819	Due to length error, RPDO not processed /processing timeout
8213	10	813	BOOT not supported
8215	10	815	Invalid mailbox configuration under boot state
8216	10	816	Pre-Op status is invalid for the mailbox configuration
8217	10	817	Invalid SyncManager configuration
821B	10	81B	SyncManager2 watchdog timer timeout

821C	10	81C	Invalid SyncManager type
821D	10	81D	Invalid output configuration
821E	10	81E	Invalid input configuration
821F	10	81F	Watchdog configuration invalid
8220	10	820	PDO length over limit
8224	10	824	TPDO mapping invalid
8225	10	825	RPDO mapping invalid
8226	10	826	Configuration non-consistent
8310	2	101	Motor overloaded
8311	2	100	Driver overloaded
8305	2	105	Torque over limit
8401	20	190	Motor vibration too strong
8402	20	1A0	Overspeed
8403	20	1A1	Velocity out of control
8503	20	1B1	Incorrect electronic gear ratio
8611	20	180	Excessive Position Deviation
8610	20	181	Position following error
8612	20	1B0	Excessive position increment
871A	10	81A	Synchronization error
8727	10	827	Free running mode is not supported
8728	10	828	Sync mode not supported
872C	10	82C	Invalid inputs and outputs
872D	10	82D	Fatal synchronization error
872E	10	82E	No synchronization error
8730	10	830	Invalid Distributed Clock synchronization settings
8732	10	832	Distribution Clock phase-locked loop failure
8733	10	833	DC sync IO error

8734	10	834	DC sync timeout
8735	10	835	Distribution Clock cycle time is invalid
8736	10	836	SYNC0 cycle time invalid
8737	10	837	SYNC1 cycle time invalid
873A	10	73A	SyncManager2 lost
873B	10	73B	SYNC0 lost
873C	10	73C	Excessive Distributed Clock error

When error occurs, drive will take protection measures and stops the motor. Error code will be shown on tuning software or master device (controller) can read corresponding error code from object dictionary. Please refer to the table below.

603F (HEX)	1001 (HEX)	Alarm code(HEX)	Alarm
2211	2	0E0	Software overcurrent
2212	2	0E1	Hardware overcurrent
3130	4	0D1	Phase missing
3150	4	0A0	Phase A circuit current detection error
3151	4	0A1	Phase B circuit current detection error
3152	4	0A2	Analog input 1 circuit error
3153	4	0A3	Motor power cable not connected
3154	4	0A4	Analog input 2 circuit error
3160	4	270	Excessive analog input 1
3161	4	271	Excessive analog input 2
3162	4	272	Excessive analog input 3
3201	4	0A5	DC bus base voltage error
3205	4	0B0	Control circuit voltage too low
3206	4	0B1	Control circuit voltage too high
3211	4	0C0	DC bus voltage too high
3221	4	0D0	DC bus voltage too low

3222	4	0D2	Main power supply disconnected
4201	8	0A6	Temperature base sampling error
4210	8	0F0	Drive over-temperature
5201	80	870	Servo unable to enable under current mode

7.2 Alarm Handling

***When error occurs, please solve accordingly. Then, restart.*

Error code	Main	Sub	Display: "Er 090"
	09	0~F	Content: FPGA communication error
Cause			Diagnosis
Driver fault			/
			Solution
			Replace driver

Error code	Main	Sub	Display: "Er 0A0"--"Er 0A1"
	0A	0~1	Content: Circuit current detection error
Cause			Diagnosis
Motor power cable wiring error			Verify motor power cable wiring
Main power supply undervoltage			Verify L1,L2,L3 terminal voltage
Driver fault			/
			Solution
			Make sure U,V,W terminal wired properly
			Increase main power supply voltage
			Replace driver

Error code	Main	Sub	Display: "Er 0A2", "Er 0A4"
	0A	2/4	Content: Analog input circuit error
Cause			Diagnosis
Analog input wiring			Verify analog input wiring
Driver fault			/
			Solution
			Make analog input wiring is correct
			Replace driver

Error code	Main	Sub	Display: "Er 0A3"
	0A	3	Content: Motor power cable not connected
Cause			Diagnosis
Motor power cable not connected			Verify motor power cable wiring
Motor fault			/
Driver fault			/
			Solution
			Measure resistance values between U, V, W terminals , make sure the values are almost equal. If not, might be due to damaged motor or motor winding open circuit.
			Replace motor
			Replace driver

Error code	Main	Sub	Display: "Er 0A5"
	0A	5	Content: DC bus circuit error
Cause			Diagnosis
Driver fault			/
			Solution
			Replace driver

Error code	Main	Sub	Display: "Er 0A6"
	0A	5	Content: Temperature detection circuit error
Cause			Diagnosis
Driver fault			/
			Solution
			Replace driver

Error code	Main	Sub	Display: "Er 0b0"
	0b	0	Content: Control circuit power supply low
Cause			Diagnosis
Control circuit power supply too low			Check if wiring is correct; Check the voltage on power supply input
Power supply capacity low			/
			Solution
			Fix wiring error
			Replace power supply or use independent power supply for control circuit

Error code	Main	Sub	Display: "Er 0c0"
	0c	0	Content: DC bus overvoltage
Cause			Diagnosis
Main power supply overvoltage			Verify L+,L- terminal voltage
Driver fault			/
			Solution
			Decrease main power supply voltage
			Replace driver

Error code	Main	Sub	Display: "Er 0d0"
	0d	0	Content: DC bus undervoltage
Cause			Diagnosis
Main power supply undervoltage			Verify L-,L+ terminal voltage
Driver fault			/
			Solution
			Increase main power supply voltage
			Replace driver

Error code	Main	Sub	Display: "Er 0d2"
	0d	2	Content: No main power supply detected
Cause			Diagnosis
No main power supply			Verify L1,L2,L3 terminal voltage
Driver fault			/
			Solution
			1. Increase main power supply voltage 2. Secure connections
			Replace driver

Error code	Main	Sub	Display: "Er OE0"	
	0E	0	Content: Overcurrent	
Cause			Diagnosis	Solution
Driver power output short circuit			Verify if there is short circuit between UVW terminals, or shorted to PG.	1. Make sure there is no circuit. 2. Make sure motor is not damaged
Motor wiring error			Verify motor wiring	Reconnect motor wiring
IGBT module short circuit			Disconnect motor output cable. Then, enable servo driver to check for overcurrent	Replace driver
Excessive motor load			Verify if motor torque output is too high	1. Reduce load 2. Add a gearbox
Excessive acceleration and deceleration			Verify if acceleration and deceleration duration time are too low	Increase acceleration and deceleration duration time
Motor wiring short circuit			Connect motor power cable to driver power output. Verify if resistance value of UVW to PE is equal and if there is short circuit	Replace motor

Error code	Main	Sub	Display: "Er OE1"	
	0E	1	Content: Intelligent Power Module (IPM) overcurrent	
Cause			Diagnosis	Solution
Driver power output short circuit			Verify if there is short circuit between UVW terminals, or shorted to PG.	1. Make sure there is no circuit. 2. Make sure motor is not damaged
Motor wiring error			Verify motor wiring	Reconnect motor wiring
IGBT module short circuit			Disconnect motor output cable. Then, enable servo driver to check for overcurrent	Replace driver
IGBT module undervoltage			/	Replace driver
Excessive motor load			Verify if motor torque output is too high	1. Reduce load 2. Add a gearbox
Excessive acceleration and deceleration			Verify if acceleration and deceleration duration time are too low	Increase acceleration and deceleration duration time
Motor wiring short circuit			Connect motor power cable to driver power output. Verify if resistance value of UVW to PE is equal and if there is short circuit	Replace motor

Error code	Main	Sub	Display: "Er 0F0"
	0F	0	Content: Driver overheated
Cause		Diagnosis	Solution
Temperature of power module exceeded upper limit		Measure the temperature of driver radiator.	1. Improve cooling condition. Please check installation guide; 2. Replace driver and motor with higher power rating; 3. Increase duration time for acceleration and deceleration; 4. Decrease load

Error code	Main	Sub	Display: "Er 100"
	10	0	Content: Motor overloaded
Cause		Diagnosis	Solution
Load too heavy		Verify if actual load exceeds maximum value allowed	1. Decrease load 2. Adjust limit values
Strong mechanical vibration		Look for mechanical vibration from machine system	1. Adjust gain value of control loop 2. Increase duration time for acceleration and deceleration
Motor or encoder cable wiring error		Verify motor and encoder wiring	1. Reconnect wiring 2. Replace motor and encoder cable
Holding brake engaged		Verify holding brake terminal voltage	Cut off holding brake

Error code	Main	Sub	Display: "Er 101"
	10	1	Content: Drive overload
Cause		Diagnosis	Solution
Motor power supply connection incorrect		Verify UVW wiring	Make UVW wiring is correct
Motor mismatched		Motor rated current is higher than drive max. output current	Change motor with lower current rating or drive with higher current output

Error code	Main	Sub	Display: "Er 102"
	10	2	Content: Motor rotor blocked
Cause		Diagnosis	Solution
Motor rotor blocked		Look for mechanical blockages	Check the machinery
Motor rotor blocking time threshold value too low		Verify value of Pr6.57	Adjust value of Pr6.57

Error code	Main	Sub	Display: "Er 120"	
	12	0	Content: Regenerative resistor overvoltage	
Cause			Diagnosis	Solution
Regenerative energy exceeded capacity of regenerative resistor			1. Verify if velocity is too high 2. Verify if load is too large	1. Decrease motor rotational velocity; 2. Decrease load inertia; 3. Add an external regenerative resistor;
Power supply voltage too high			1. Verify if power supply voltage is within the rated range. 2. Interval regenerative resistor value is too low	1. Decrease power supply voltage 2. Increase regeneration resistance value(add external regenerative resistor)
Unstable power supply voltage			Verify if power supply voltage is stable	Add a surge suppressor to main power supply.
Regenerative energy discharge circuit damaged			/	1. Add an external regenerative resistor; 2. Replace driver

Error code	Main	Sub	Display: "Er 121"	
	12	1	Content: Holding brake error	
Cause			Diagnosis	Solution
Holding brake circuit damaged			Regenerative resistor disconnected	Replace regenerative resistor
			Holding brake IGBT damaged	Replace driver

Error code	Main	Sub	Display: "Er 122"	
	12	2	Content: Regenerative resistor value too low	
Cause			Diagnosis	Solution
External regenerative resistor value is less than the minimum value allowed by the drive			/	Replace the regenerative resistor with the right resistance value which meets the specification of the driver

Error code	Main	Sub	Display: "Er 150"	
	15	0	Content: Encoder disconnected	
Cause			Diagnosis	Solution
Encoder cable disconnected			Verify encoder cable connection	Make sure encoder cable properly connected
Encoder cable wiring error			Verify if encoder wiring is correct	Reconnect encoder wiring
Encoder damaged			/	Replace motor
Encoder measuring circuit damaged			/	Replace driver

Error code	Main	Sub	Display: "Er 151"
	15	1	Content: Encoder communication error
Cause			Solution
Encoder wire shielding layer is missing			Replace with standard encoder cable
Encoder cable wiring error			Reconnect encoder wiring
Encoder damaged			Replace motor

Error code	Main	Sub	Display: "Er 152"
	15	2	Content: Encoder initial position error
Cause		Diagnosis	Solution
Communication data abnormal		1. Verify if encoder power supply voltage is $DC5V \pm 5\%$; 2. Verify if encoder cable and shielded layer is not damaged; 3. Verify if encoder cable is close to high-powered power supply cable	1. Make sure encoder power supply voltage is stable 2. Make sure encoder cable is not damaged. 3. Make sure encoder cable shielded layer is grounded to frame 4. Make sure encoder cable is away from high-powered power supply cable
Encoder damaged		/	Replace motor
Encoder measuring circuit damaged		/	Replace driver

Error code	Main	Sub	Display: "Er 153"
	15	3	Content: Multiturn encoder error
Cause			Solution
Initial use			Perform origin positioning and multiturn position initialization, calibrate the origin of coordinate system.
Encoder without multiturn absolute function used			1. Replace the motor with a multiturn absolute encoder. 2. Set Pr0.15 = 0 to deactivate multiturn absolute function.
Low battery power			Replace battery
Battery has no power or has been dismantled			Absolute position lost. Return to origin and perform multiturn initialization, calibrate the origin of coordinate system

Error code	Main	Sub	Display: "Er 154"
	15	4	Content: Encoder parameter settings error
Cause		Diagnosis	Solution
Absolute encoder mode is incorrectly set.		Verify if encoder has multi-turn absolute value function.	Modify absolute encoder mode settings

Error code	Main	Sub	Display: "Er 155"
	15	5	Content: Encoder data overflow
Cause		Diagnosis	Solution
Encoder data overflow		Verify if encoder is not damaged	Initialize multiturn data
Absolute value applications, motor rotates in one direction		Verify if encoder is not damaged	Adjust absolute value application mode, set to turntable mode

Error code	Main	Sub	Display: "Er 156"
	15	6	Content: Encoder overheated
Cause		Diagnosis	Solution
The encoder temperature is too high.		Verify if motor temperature is too high	Reduce encoder temperature.

Error code	Main	Sub	Display: "Er 157"
	15	7	Content: Encoder counter error
Cause		Diagnosis	Solution
Encoder data overflow		Verify if encoder is not damaged	Initialize multiturn data
Absolute value applications, motor rotates in one direction		Verify if encoder is not damaged	Adjust absolute value application mode, set to turntable mode

Error code	Main	Sub	Display: "Er 170"
	17	0	Content: Encoder data error
Cause		Diagnosis	Solution
Communication data abnormal		1. Verify if encoder power supply voltage is $DC5V \pm 5\%$; 2. Verify if encoder cable and shielded layer is not damaged; 3. Verify if encoder cable is close to high-powered power supply cable	1. Make sure encoder power supply voltage is stable 2. Make sure encoder cable is not damaged. 3. Make sure encoder cable shielded layer is grounded to frame 4. Make sure encoder cable is away from high-powered power supply cable
Encoder damaged		/	Replace motor
Encoder measuring circuit damaged		/	Replace driver

Error code	Main	Sub	Display: "Er 171"
	17	1	Content: Encoder parameter initialization error
Cause		Diagnosis	Solution
Driver and motor not matched		Verify driver and motor models.	Replace with matching driver and motor
Error while getting parameters from encoder		1. Verify if encoder cable is standard. 2. Verify if encoder has no peeled insulator, broken connection or improper contact.	Use standard encoder cable, verify the connection of both sides of driver and motor, change encoder cable if necessary

Error code	Main	Sub	Display: "Er 180"
	18	0	Content: Excessive position deviation
Cause		Diagnosis	Solution
Improper position deviation settings		Verify if value of Pr_014 is too low	Increase value of Pr_014
Position gain setting too low		Verify if values of Pr1.00 & Pr1.05 are too low	Increase values of Pr1.00 & Pr1.05
Torque limit too low		Verify if values of Pr0.13 & Pr5.22 are too low	Increase values of Pr0.13 & Pr5.22
Excessive external load		1. Verify if acceleration and deceleration duration time is too low. 2. Verify if rotational velocity is too high 3. Verify if load is too large	1. Increase duration time for acceleration and deceleration 2. Decrease rotational velocity 3. Decrease load

Error code	Main	Sub	Display: "Er 181"
	18	1	Content: Excessive velocity deviation
Cause		Diagnosis	Solution
Deviation between set velocity and actual velocity is too great		Verify if value of Pr6.02 is too low	1. Increase value of Pr6.02; 2. Set Pr6.02 to 0, position error detection off.
Acceleration and deceleration duration time for set velocity is too low		Verify if value of Pr3.12 and Pr3.13 are too low	1. Increase value of Pr3.12, Pr3.13; 2. Adjust velocity gain to reduce velocity lag error

Error code	Main	Sub	Display: "Er 190"
	19	0	Content: Motor vibration too strong
Cause		Diagnosis	Solution
Motor velocity fluctuates too much		Verify if Pr0.03 is too large	Decrease value of Pr0.03

Error code	Main	Sub	Display: "Er 1A0"
	1A	0	Content: Overspeed
Cause		Diagnosis	Solution
Motor velocity exceeded first speed limit (Pr3.21)		1. Verify if velocity command is too high; 2. Verify if simulated velocity command voltage is too high; 3. Verify if parameter value of Pr3.21 is too low; 4. Verify if input frequency and division frequency coefficient of pulse train is proper; 5. Verify if encoder is wired correctly	1. Adjust velocity input command; 2. Increase Pr3.21 value; 3. Adjust pulse train input frequency and division frequency coefficient; 4. Verify encoder wiring;

Error code	Main	Sub	Display: "Er 1A1"
	1A	1	Content: Velocity out of control
Cause		Diagnosis	Solution
Motor velocity out of control, Excessive velocity error		Verify encoder phase sequence; Verify if UVW cable is connected to the right terminal	Reconnect UVW if wrongly connected. If still remains unsolved, please contact technical support.

Error code	Main	Sub	Display: "Er 1b0"
	1b	0	Content: Bus input signal dithering
Cause		Diagnosis	Solution
Controller synchronization dithering		/	Increase alarm threshold value

Error code	Main	Sub	Display: "Er 1b1"
	1b	1	Content: Incorrect electronic gear ratio
Cause		Diagnosis	Solution
Values out of range		Numerator or denominator is zero/Set values out of range	Reduce number of pulses per revolution

Error code	Main	Sub	Display: "Er 1c0"
	1c	0	Content: Both STO failed
Cause		Diagnosis	Solution
Both STO input signals valid		Verify if STO power supply is normal	Verify 24V STO power supply and power cable connection
		Disconnect switch connected to STO	Close switch

Error code	Main	Sub	Display: "Er 1c1"	
	1c	1	Content: 1st STO failed	
Cause			Diagnosis	Solution
1 st STO input signal valid			Verify if STO power supply is normal	Verify 24V STO power supply and power cable connection
			Disconnect switch connected to STO	Close switch

Error code	Main	Sub	Display: "Er 1c2"	
	1c	2	Content: 2nd STO failed	
Cause			Diagnosis	Solution
2 nd STO input signal valid			Verify if STO power supply is normal	Verify 24V STO power supply and power cable connection
			Disconnect switch connected to STO	Close switch

Error code	Main	Sub	Display: "Er 210"	
	21	0	Content: I/O input interface assignment error	
Cause			Diagnosis	Solution
Input signal assigned with two or more functions.			Verify values of Pr4.00-Pr4.09, Pr4.44-4.47	Set proper values for Pr4.00-Pr4.09, Pr4.44-4.47

Error code	Main	Sub	Display: "Er 211"	
	21	1	Content: I/O input interface function assignment error	
Cause			Diagnosis	Solution
Input signal assignment error			Verify values of Pr4.00-Pr4.09, Pr4.44-4.47	Set proper values for Pr4.00-Pr4.09, Pr4.44-4.47

Error code	Main	Sub	Display: "Er 212"	
	21	2	Content: I/O output interface function assignment error	
Cause			Diagnosis	Solution
Input signal assigned with two or more functions.			Verify values of Pr4.10-Pr4.15	Set proper values for Pr4.10-Pr4.15
Input signal not assigned			Verify values of Pr4.10-Pr4.15	Set proper values for Pr4.10-Pr4.15

Error code	Main	Sub	Display: "Er 240"	
	24	0	Content: EEPROM parameters initialization error	
Cause			Diagnosis	Solution
Error during initial reading of EEPROM parameters			Restart after changing any parameter. Verify if the parameter is saved.	If parameter not saved after several restarts, please change driver

Error code	Main	Sub	Display: "Er 241"
	24	1	Content: EEPROM hardware error
Cause			Diagnosis
EEPROM damaged			Verify if multiple storages are the same
			Solution
			Replace driver/Upgrade software

Error code	Main	Sub	Display: "Er 242"
	24	2	Content: Error saving alarm history record
Cause			Diagnosis
Power-off during saving			Verify alarm during power-off
Several different alarms in a row			Verify alarm code
EEPROM damaged			Verify if it is the same over several times
			Solution
			Power lost after alarm appears
			Figure out other alarm causes
			Replace driver/Upgrade software

Error code	Main	Sub	Display: "Er 243"
	24	3	Content: Error occurred when saving vendor parameters
Cause			Diagnosis
Power-off before data saved			--
EEPROM damaged			Restart driver for a few times
			Solution
			Wait until data saved successfully before powering off
			Restart driver for a few times

Error code	Main	Sub	Display: "Er 244"
	24	4	Error description: Error occurred when saving communication parameters
Cause			Diagnosis
Power-off before data saved			--
EEPROM damaged			Restart driver for a few times
			Solution
			Wait until data saved successfully before powering off
			Restart driver for a few times

Error code	Main	Sub	Display: "Er 245"
	24	5	Error description: Error occurred when saving parameter 402
Cause			Diagnosis
Power-off before data saved			--
EEPROM damaged			Restart driver for a few times
			Solution
			Wait until data saved successfully before powering off
			Restart driver for a few times

Error code	Main	Sub	Display: "Er 246"
	24	6	Error description: Data saving error during power-off
Cause			Diagnosis
Power off too fast			--
EEPROM damaged			Restart driver for a few times
			Solution
			Upgrade software
			Restart driver for a few times

Error code	Main	Sub	Display: "Er 260"
	26	0	Error description: Positive/Negative position limit triggered under non-homing mode
Cause			Diagnosis
Positive/negative position limit triggered			Verify position limit signal
			Solution
			/

Error code	Main	Sub	Display: "Er 280"
	28	0	Error description: Output pulse frequency too high
Cause			Diagnosis
Frequency divided pulse output exceeds 1MHz			Verify if motor rotational speed and the number of frequency divided pulse output are too high
			Solution
			Reduce the number of frequency divided pulse output or reduce rotational speed

Error code	Main	Sub	Display: " Er 570"
	57	0	Error description: Forced alarm input valid
Cause			Diagnosis
Forced alarm input signal occurred			Verify forced alarm input signal
			Solution
			Verify if the input wiring connection is correct

Error code	Main	Sub	Display: "Er 5F0"
	5F	0	Content: Motor model no. detection error
Cause			Diagnosis
Automatically detected motor doesn't match set motor			/
			Solution
			Please contact our technical support

Error code	Main	Sub	Display: "Er 5F1"
	5F	1	Error description: Driver power module detection error
Cause			Diagnosis
Driver power rating not within range.			Restart driver
			Solution
			Please contact our technical support

Error code	Main	Sub	Display: "Er 600"
	60	0	Error description: Main loop interrupted timeout
Cause			Diagnosis
The motor control loop calculation time overflow			Check for interference from devices releasing electromagnetic field
			Restart driver
			Solution
			Ground driver and motor to reduce interference
			Replace driver

Error code	Main	Sub	Display: "Er 601"
	60	1	Error description: Velocity loop interrupted timeout
Cause		Diagnosis	Solution
Motor control loop calculation time overflow		Verify if encoder connection is and that the encoder cable is too not long (more than 20 meters)	Replace encoder cable if necessary
		Restart driver	Replace the drive with a new one

Error code	Main	Sub	Display: "Er 700"
	70	0	Error description: Encryption error
Cause		Diagnosis	Solution
Encryption error during initialization upon power-on.		Restart driver	Please contact our technical support

7.3 CANopen Communication Alarm

CANopen communication related alarms are erasable and will not be recorded in alarm history. Clearing CANopen communication alarm is similar to clearing servo driver alarm. Please clear the alarm before switching to 402 machine state.

CANopen communication alarm however, relies on register clearance from the main station. Can be solved according to following steps:

- 1、Set bit 4 of ESC control register 0x120 (error responder) to 1.
- 2、The communication alarm can be cleared until the feedback of the ESC status code register 0x134~0x135 is 0.
- 3、By setting bit 7 of 6040h to 1, switches state machine from fault to initialization completion , No fault(Switch on disabled).

Error code	Main	Sub	Display: "Er 73A"
	73	A	Error description: SyncManager2 lost
Cause		Diagnosis	Solution
Poor master performance		--	Increase the alarm threshold
Single-unit drive has problem		Is it a single unit or multiple units together in the network	Switch drive
interfere		Check the grounding and network wiring quality	Replace the network cable

Error code	Main	Sub	Display: "Er 73b"
	73	B	Error description: SYNC0 lost
Cause		Diagnosis	Solution
Poor master performance		--	Increase threshold value limit
Single-unit drive has problem		Is it a single unit or multiple units together in the network	Switch drive
Interfere		Check the grounding and network wiring quality	Replace the network cable

Error code	Main	Sub	Display: "Er 73c"
	73	C	Error description: Excessive Distributed Clock error
Cause		Diagnosis	Solution
Poor master device performance		--	Increase threshold value limit
Single-unit drive has problem		Is it a single unit or multiple units together in the network	Replace driver
Interfere		Check the grounding and network wiring quality	Replace network cable

Error code	Main	Sub	Display: "Er 801"
	80	1	Error description: Unknown communication error
Cause		CANopen state machine transition failed	
The status of the error can be detected		All ESM status	
The result status		The current state is maintained below the safe operation, and the operation state is switched to the safe operation state	
Solution		Verify network connection and master device CANopen state machine transition order	

Error code	Main	Sub	Display: "Er 802"
	80	2	Error description: Memory overflow
Cause		CPU failed to request memory	
The status of the error can be detected		All ESM status	
The result status		The current state is maintained below the safe operation, and the operation state is switched to the safe operation state	
Solution		Verify if LD2-CAN hardware is faulty	

Error code	Main	Sub	Display: "Er 803"
	80	3	Error description: RAM out of bound
Cause			CANopen state machine memory address access request from master device is out of bound
The status of the error can be detected			All communication status
The result status			NO
Solution			Verify master device configuration or replace master device

Error code	Main	Sub	Display: "Er 805"
	80	5	Error description: FOE firmware upgrade failed
Cause			Firmware burn error
The status of the error can be detected			BOOT
The result status			Remain in the detection state
Solution			Replace firmware/driver

Error code	Main	Sub	Display: "Er 806"
	80	6	Error description: Saved ESI file does not match driver firmware
Cause			ESI file does not match driver firmware
The status of the error can be detected			INIT
The result status			Remain in the detection state
Solution			Burn matching firmware to driver

Error code	Main	Sub	Display: "Er 811"
	81	1	Error description: Invalid CANopen transition request
Cause			Driver received unconvertible request from CANopen state machine
The status of the error can be detected			All ESM Status
The result status			The current state is maintained below the safe operation, and the operation state is switched to the safe operation state
Solution			Verify if the transition information from master device is correct

Error code	Main	Sub	Display: "Er 812"
	81	2	Error description: Unknown CANopen state machine transition request
Cause			Driver receives a transition request other than states of the CANopen state machine
The status of the error can be detected			All ESM Status
The result status			The current state is maintained below the safe operation, and the operation state is switched to the safe operation state
Solution			Verify transition information from master device

Error code	Main	Sub	Display: "Er 813"
	81	3	Error description: Protection request from boot state
Cause			Driver receives a transition request to boot state
The status of the error can be detected			Initialize the conversion to a boot
The result status			initialization
Solution			Verify if driver software version supports this state transition

Error code	Main	Sub	Display: "Er 814"
	81	4	Error description: Invalid firmware
Cause			Firmware not matched with driver
The status of the error can be detected			BOOT/INIT
The result status			Keeping in the detection status
Solution			Return driver to supplier to update firmware

Error code	Main	Sub	Display: "Er 815"
	81	5	Error description: Invalid mailbox configuration under boot state
Cause			Boot state action not supported under current configuration
The status of the error can be detected			Initialize the conversion to a boot
The result status			Initialization
Solution			Verify if LD2-CAN software version supports action under this state.

Error code	Main	Sub	Display: "Er 816"
	81	6	Error description: Pre-Op status is invalid for the mailbox configuration
Cause			The synchronization manager configuration under Pre-Op is invalid
The status of the error can be detected			pre-operation
The result status			initialization
Solution			1. Verify if ESI file version is consistent with software version 2. CANopen slave controller error, please contact technical support

Error code	Main	Sub	Display: "Er 817"
	81	7	Error description: Invalid SyncManager configuration
Cause			Synchronization manager configuration is invalid
The status of the error can be detected			Pre-op above
The result status			Pre-op
Solution			Verify master device configuration/ESI file version

Error code	Main	Sub	Display: "Er 818"
	81	8	Error description: No valid input data
Cause			The input data is not updated for more than 1 second
The status of the error can be detected			All ESM status
The result status			The current state is maintained below the safe operation, and the operation state is switched to the safe operation state
Solution			1. Verify if TxPDO is valid 2. Verify master device synchronization settings

Error code	Main	Sub	Display: "Er 819"
	81	9	Error description: No valid output data
Cause			Output data is not updated for more than 1 second
The status of the error can be detected			All ESM status
The result status			The current state is maintained below the safe operation, and the operation state is switched to the safe operation state
Solution			1. Verify if RxPDO is valid 2. Verify master device synchronization settings

Error code	Main	Sub	Display: "Er 81A"
	81	A	Error description: Synchronization error
Cause			RxPDO and DC update order failed or one of them is not updated in sync
The status of the error can be detected			All ESM status
The result status			The current state is maintained below the safe operation, and the operation state is switched to the safe operation state
Solution			1. Verify if PXPDO is valid 2. Verify master device synchronization settings

Error code	Main	Sub	Display: "Er 81b"
	81	b	Error description: SyncManager2 watchdog timer timeout
Cause			The RxPDO update timeout in operational state
The status of the error can be detected			operation
The result status			Safe operation
Solution			1. Verify if LD2-CAN network is connected 2. Verify RxPDO update time

Error code	Main	Sub	Display: "Er 81c"
	81	c	Error description: Invalid SyncManager type
Cause	Synchronization Manager configuration types other than the following: 1. Email output 2. Email input 3. Process data output 4. Process data input		
The status of the error can be detected	Pre-operation		
The result status	Initialize		
Solution	Verify if ESI file version is consistent with software version		

Error code	Main	Sub	Display: "Er 81d"
	81	d	Error description: Invalid output configuration
Cause	Process data output synchronization manager configuration is invalid		
The status of the error can be detected	Pre-operation		
The result status	Initialize		
Solution	1. Verify LD2-CAN synchronization manager configuration 2. Verify if ESI file version is consistent with software version		

Error code	Main	Sub	Display: "Er 81E"
	81	E	Error description: Invalid input configuration
Cause	Process data input synchronization manager configuration is invalid		
The status of the error can be detected	Pre-operation		
The result status	Initialize		
Solution	1. Verify LD2-CAN synchronization manager configuration 2. Verify if ESI file version is consistent with software version		

Error code	Main	Sub	Display: "Er 821"
	82	1	Error description: Waiting for CANopen state machine Init state
Cause	Driver waiting for master device to send Init request		
The status of the error can be detected	All ESM status		
The result status	Keeping the current state		
Solution	Verify transition request sent from master device		

Error code	Main	Sub	Display: "Er 822"
	82	2	Error description: Waiting for the CANopen state machine Pre-Op state
Cause			Driver waiting for master device to send Pre-Op request
The status of the error can be detected			Safe operation, operation
The result status			Keeping the current state
Solution			Verify transition request sent from master device

Error code	Main	Sub	Display: "Er 823"
	82	3	Error description: Waiting for master device for Safe-Op request
Cause			Process data output synchronization manager configuration is invalid
The status of the error can be detected			Operation
The result status			Keeping the current state
Solution			Verify transition request sent from master device

Error code	Main	Sub	Display: "Er 824"
	82	4	Error description: Invalid process data input mapping
Cause			TxPDO is configured with non-mappable objects
The status of the error can be detected			Safe operation
The result status			Pre-operation
Solution			Reconfigure the TxPDO mapping object

Error code	Main	Sub	Display: "Er 825"
	82	5	Error description: Invalid process data output mapping
Cause			RxPDO is configured with non-mappable objects
The status of the error can be detected			Safe operation
The result status			Pre-operation
Solution			Reconfigure the RxPDO mapping object

Error code	Main	Sub	Display: "Er 828"
	82	8	Error description: Sync mode not supported
Cause			Sync mode is not supported in the current configuration
The status of the error can be detected			Safe operation
The result status			Pre-operation
Solution			1. Verify LD2-CAN software version 2. Verify ESI version

Error code	Main	Sub	Display: "Er 82b"
	82	b	Error description: Invalid inputs and outputs
Cause			No RxPDO and TxPDO updates for more than 1 second
The status of the error can be detected			All ESM status
The result status			The current state is maintained below the safe operation, and the operation state is switched to the safe operation state
Solution			<ol style="list-style-type: none"> 1. Verify if current RxPDO and TxPDO are invalid 2. Verify master device synchronization settings

Error code	Main	Sub	Display: "Er 82c"
	82	c	Error description: Fatal synchronization error
Cause			DC watchdog timer timeout
The status of the error can be detected			Safe operation, operation
The result status			Safe operation
Solution			<ol style="list-style-type: none"> 1. Verify if LD2-CAN hardware is faulty 2. Verify DC setting and delay

Error code	Main	Sub	Display: "Er 82d"
	82	d	Error description: No synchronization error
Cause			Synchronization is invalid
The status of the error can be detected			operation
The result status			Safe operation
Solution			<ol style="list-style-type: none"> 1. Verify if "fatal synchronization error" has occurred. 2. Verify master device synchronization settings

Error code	Main	Sub	Display: "Er 82E"
	82	E	Error description: Synchronization cycle time is too short
Cause			Master device synchronization cycle time is set to less than 125 microseconds
The status of the error can be detected			operation
The result status			Pre-operation
Solution			Verify master device synchronization cycle time

Error code	Main	Sub	Display: "Er 830"
	83	0	Error description: Invalid Distributed Clock synchronization settings
Cause			Synchronization settings in sync mode are not valid
The status of the error can be detected			Safe operation
The result status			Pre-operation
Solution			Verify master device synchronization settings

Error code	Main	Sub	Display: "Er 832"
	83	2	Error description: Distribution Clock phase-locked loop failure
Cause			Distribution Clock phase-locked loop setting is invalid
The status of the error can be detected			Safe operation, operation
The result status			Safe operation
Solution			Verify master device Distribution Clock settings and network transmission delay

Error code	Main	Sub	Display: "Er 835"
	83	5	Error description: Distribution Clock cycle time is invalid
Cause			Set synchronization cycle time is not proportional to drive position loop
The status of the error can be detected			Safe operation
The result status			Pre-operation
Solution			Refer to user manual to set a reasonable synchronization cycle time.

Error code	Main	Sub	Display: "Er 836"
	83	6	Error description: Invalid Distribution Clock synchronization cycle time
Cause			The synchronization cycle time setting is not as the following 1 : 125us 2 : 250us 3 : 500us 4 : 750us 5 : 1000us 6 : 2000us 7 : 4000us
The status of the error can be detected			Safe operation
The result status			Pre-operation
Solution			Verify master device synchronization cycle time

Error code	Main	Sub	Display: "Er 850"
	85	0	Error description: EEPROM is inaccessible
Cause			CANopen slave controller failed to access EEPROM
The status of the error can be detected			All ESM status
The result status			Keeping the current state
Solution			1. Verify if LD2-CAN hardware is faulty 2. Verify if master device released access

Error code	Main	Sub	Display: "Er 851"
	85	1	Error description: EEPROM error
Cause			EEPROM operation of CANopen slave controller failed
The status of the error can be detected			All ESM status
The result status			Keeping the current state
Solution			Verify if master device released access

Error code	Main	Sub	Display: "Er 852"
	85	2	Error description: Hardware is not ready
Cause			Data communication lost
The status of the error can be detected			All ESM status
The result status			Keeping the current state
Solution			Verify if LD2-CAN hardware is faulty

Error code	Main	Sub	Display: "Er 860"
	86	0	Error description: CANopen frame lost per unit time exceeds limit
Cause			CANopen frame lost per unit time exceeds the setting in 2635-00h
The status of the error can be detected			All states
The result status			Keeping the detection state
Solution			Change to network cable with higher bandwidth / Replace driver

Error code	Main	Sub	Display: "Er 870"
	87	0	Error description: Driver can't be enabled under current control mode
Cause			Enable driver under unsupported mode
The status of the error can be detected			All status
The result status			Maintain status
Solution			Switch to the correct control mode

7.4 Alarm clearing

7.4.1 Servo Drive Alarm Clearing

Clearable Alarm

Please clear alarm using Motion Studio after solving the error by clicking on the “Clear” button.

Alarm ×

Current | History | Cause(s) of motor not rotating

Device	Alarm Code	Alarm label	Clearable	Error Level	
Axis1	Err0B2		No	2	

Non-clearable Alarm

Please restart drive to clear alarm

Contact Us

Leadshine Technology Co., Ltd.

Headquarters

Address:
15-20/F, Block B, Nanshan I Valley, No.3157, Nanshan District,
Shenzhen City, Guangdong Province, China
Tel:
+86 755 26411692
Fax:
+86 755 26402718
Website:
www.leadshine.com
Emails:
sales@leadshine.com

Leadshine Global Retailers Network



Get in touch with us or any of your local Leadshine certified retailers by visiting our global website.

Technical Support

Tel: 86-755-2641-8447
86-755-2641-8774 (Asia, Australia, Africa)
86-755-2665-5136 (North and South America)
86-755-8654-2465 (Europe)
Fax: 86-755-2640-2718
Email: tech@leadshine.com

Sales Hot Line

Tel: 86-755-2641-7674 (Asia, Australia, Africa)
86-755-2641-7617 (North and South America)
86-755-2640-9254 (Europe)
Email: sales@leadshine.com

Leadshine Overseas



Leadshine America, Inc.

North America Office

Address:
26050 Towne
Centre Dr.
Foothill
Ranch California
United States
Tel:
1-949-608-7270
Fax:
1-949-638-7298
Website:
www.leadshineusa.com
Emails:
sales@leadshineusa.com