

HTK38

Series
Actuator

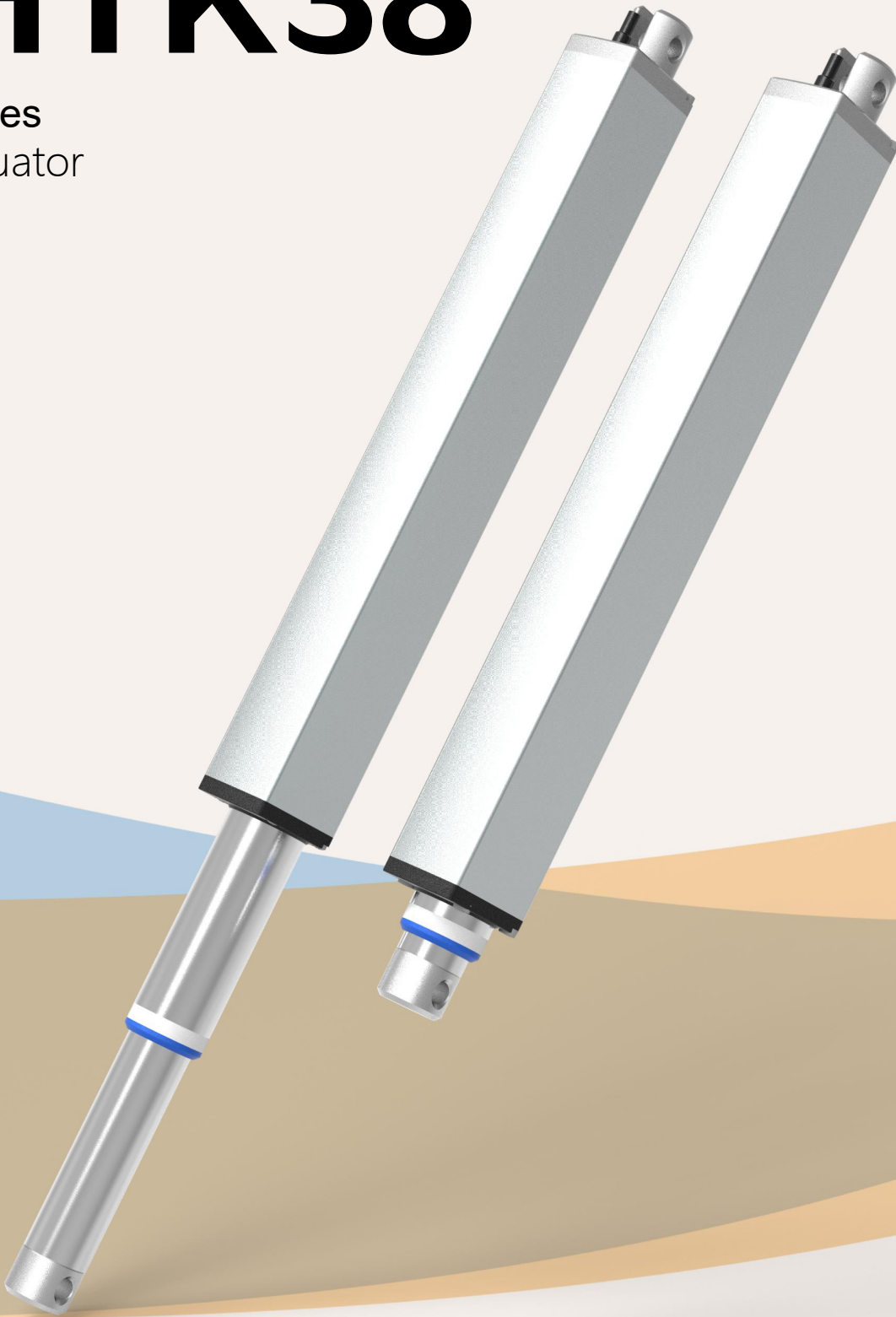

HTK38

Series

Actuator

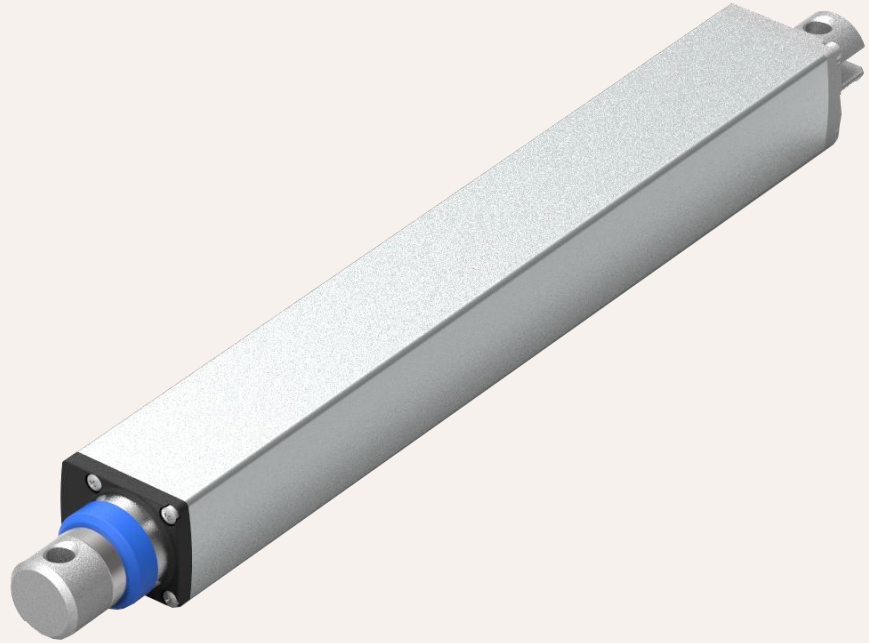

Product Category

1. Industrial application
2. Automotive applications
3. Firefighting

Download 3D model



HTK38 is one of the powerful products in the industrial application product line. The compact installation size allows the K38 to be installed in small space applications without worrying about affecting its performance. The applicable industries of HTK38 are construction machinery, ventilation systems, or food and beverage automation equipment...etc.

Functional Overview

| | |
|------------------------------|---|
| Voltage: | 12V DC or 24V DC |
| Maximum thrust (pull force): | 1,500N |
| Slowest speed under load: | 5 mm/s (load 1,500N) |
| Maximum speed under load: | 100 mm/s (load 100N) |
| Minimum installation size: | Stroke /2 + 260mm |
| Dynamic lateral moment: | 30Nm |
| Static lateral moment: | 40Nm |
| color: | Silver gray, black |
| Voice: | 52~58 DB |
| Adaptable temperature range: | -35°C ~ +75°C |
| Protection level: | IP65 |
| Screw selection: | Trapezoidal screw, ball screw (default trapezoidal screw) |
| Switch type: | Built-in limit switch, |
| Signal options: | Hall sensor, active signal, passive signal, |
| Control options: | CE and RoHS regulations, |
| safety certificate: | Synchronous control, independent control Comply with ISO9001-2008, |

Automation field applications

Actuator system provides smooth linear electric motion to the motor

Everything becomes easy to control and easy to integrate

Due to its small size, it is put into a straw cone blower. GeMinG actuators are usually classified with more complex hydraulic systems and actuators, are easy to install, and provide reliable and simple operation even in harsh conditions.

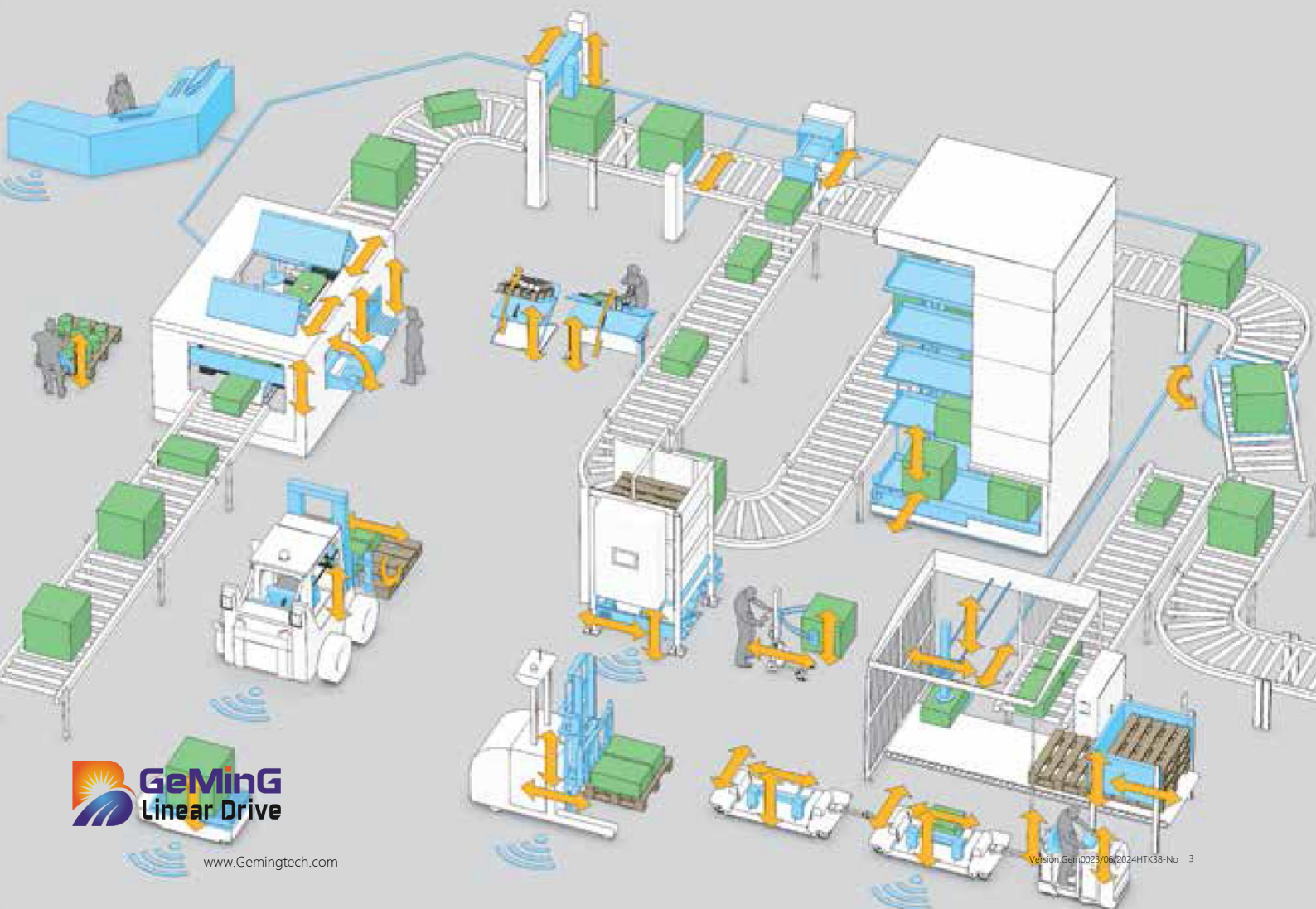

Drawings

Standard size
MM

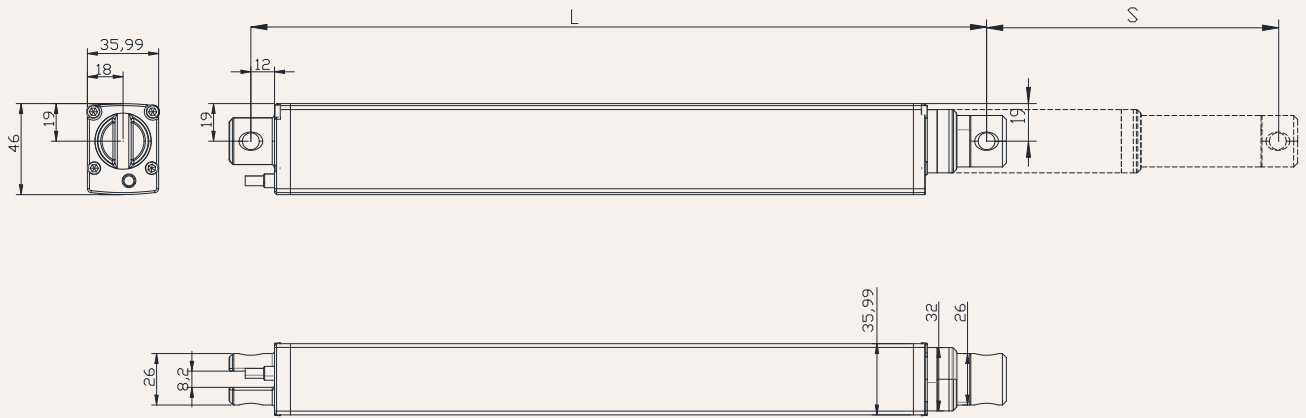

S: Stroke

L: Retracted length

L= Stroke / 2 + 260mm

Greater than 1000MM stroke, installation dimensions L= Stroke / 2 + 280MM

Installation angle (counterclockwise):

0 = 0 Degrees

9 = 90 Degrees

G=Adjust at will

load and speed

| Code | Rated load Thrust N | Pull N | Self-locking force static conditions static N | Rated load current A | Output speed no load 24V DC mm/s | Rated load 24V DC mm/s |
|------------------------|---------------------|--------|---|----------------------|----------------------------------|------------------------|
| Motor voltage (24V DC) | | | | | | |
| A | 1,500 | 1,500 | 2,000 | 4.1 | 6.0 | 4.8 |
| B | 950 | 950 | 1,000 | 4.1 | 12 | 9.5 |
| C | 400 | 400 | 400 | 4.1 | 26 | 21 |
| D | 200 | 200 | 200 | 3.8 | 53 | 42 |
| E | 100 | 100 | 100 | 3.8 | 100 | 85 |

Remark

1. The speed and current on the upper side are the materials that extend when pushed.
2. For 12V motor, the speed is about the same and the current is about 2 times higher.
3. The current & speed in the table are the test average values in the extension direction under thrust application.
4. The current & speed in the table and graph are the test average values of the GeMinG control box configuration, and there is an error of about 10% depending on the control box model.
(The voltage is about 29V DC at no load, and drops to about 24V DC at rated load)

Stroke: minimum value $\geq 20\text{mm}$, please refer to the table below for the maximum value of load and stroke

| load (N) | Maximum stroke (mm) |
|----------|---------------------|
| 2,000 | 50-200 |
| 1,200 | 201-300 |
| 1,000 | 301-400 |
| 800 | 401-600 |
| 600 | 601-900 |

Remark:

Lateral moment Y direction = $X \times 0.8$

Static lateral moment = dynamic $\times 2$

Dynamic lateral moment (Nm)-X direction

| stroke | S+230 | S+250 |
|---------|-------|-------|
| 100-200 | 50 | 80 |
| 300-500 | 40 | 60 |
| 500-700 | 30 | 50 |
| 700-900 | 20 | 40 |

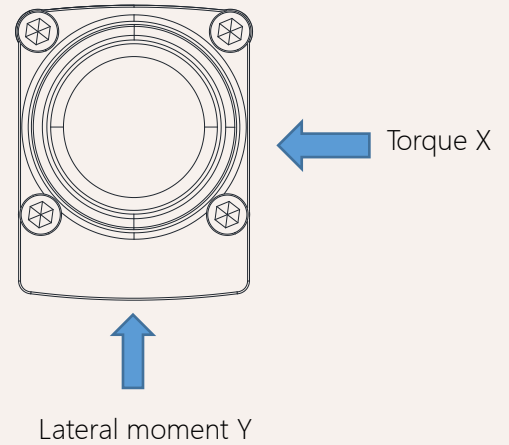

Stroke installation size reference chart

| HTK38 Series | stroke ± 2 (mm) | | | | | Install ± 2 (mm) | | | | |
|--------------|---------------------|-----|-----|-----|-----|----------------------|-----|-----|-----|--|
| strokeMM | 100 | 200 | 300 | 400 | 500 | 600 | 700 | 800 | 900 | |
| Install MM | 310 | 360 | 410 | 460 | 510 | 560 | 610 | 660 | 710 | |
| weight KG | 1,5 | 1.8 | 2.1 | 2.4 | 2.7 | 3.0 | 3.3 | 3.6 | 3.9 | |

Actuator wiring diagram

No signal feedback wiring diagram

Code: N

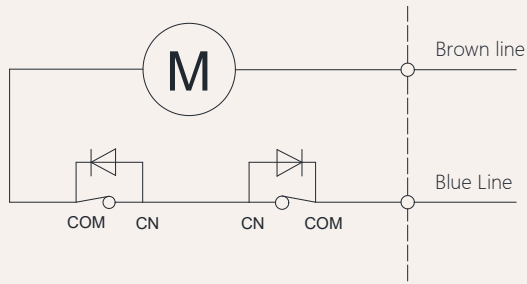

Wiring Instructions:

- 1] Brown lead: motor positive +
- 2] Blue lead: motor negative pole -
- 3] When the push rod is extended: the brown wire is positive +, the blue wire is negative -
- 4] When the push rod is retracted: the blue line is positive +, the brown line is negative -

Actuator wiring diagram Built-in control module

Built-in controller wiring diagram

Code: NY

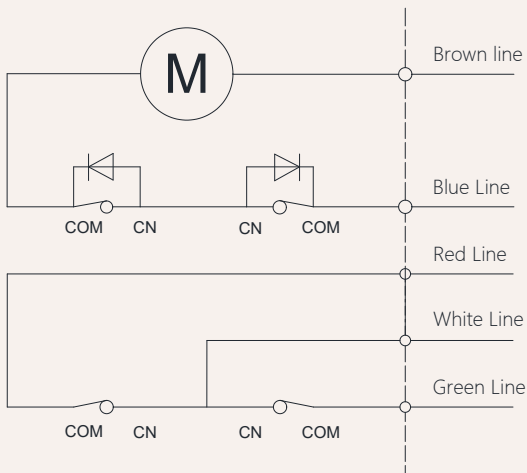

Wiring Instructions:

- 1] Brown lead: motor positive +
- 2] Blue lead: motor negative pole -
- 3] When the push rod is extended: white line + red line
- 4] When the push rod retracts: white line + green line
- 5] White line: control output common line.
- 6] White and red lines: stretch out,
- 7] White and green lines: retract,
- 8] Wireless remote control, use wired control simultaneously.

Other signal descriptions

| Feedback signal | Description | Function |
|----------------------------------|-------------------------|--|
| Active endpoint feedback signal | Voltage with this model | When the push rod reaches the end point, a signal will be fed back. This signal will always exist and will disappear during the operation of the push rod., When the push rod reaches the end point, it will feedback a signal. This signal always exists when the input power is not turned off. When the input power is turned off, the signal disappears. The signal will also disappear during the operation. |
| Passive endpoint feedback signal | No voltage | |

Note: For other needs, please contact the GeMinG team

Signal feedback Hall sensor

Hall signal motor circuit diagram

Code: H

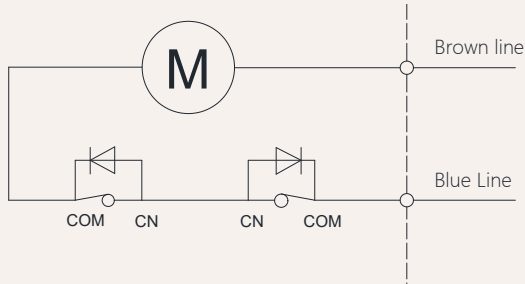

Hall signal output waveform diagram

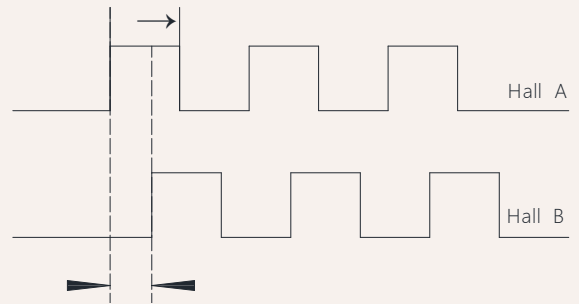

Schematic diagram of the internal circuit of the Hall signal

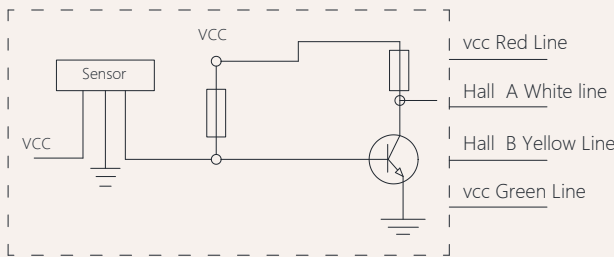

Wiring Instructions:

- 1] Brown lead: positive pole of motor +
- 2] Blue lead: negative pole of motor -
- 3] Red lead: VCC 5V voltage input +
- 4] Green lead: GND 5V voltage input -
- 5] White lead: Hall signal output A
- 6] Yellow lead: Hall signal output B

Notes:

- 1) Support dual-channel/single-channel Hall encoder
- 2) Current-consuming digital output
- 3) High-speed response frequency from: 0 KHz-100 KHz
- 4) Applicable temperature range:-40 °C~+125 °C

| Characteristics | Symbol | Test conditions | MI | RE | M | Unit |
|---------------------------|---------|-----------------------------|-----|-----|-----|------|
| Supply voltage | Vcc | ---- | 3.5 | --- | 24 | V |
| Output saturation voltage | Vce/sat | Vcc=14V ; Ic=20mA | --- | 300 | 700 | MV |
| Output leakage current | 1 cex | Vce=14V ; Vcc=14V | --- | <0 | 10 | UA |
| Input voltage | 1 ce | Vcc=20V ; Output open | --- | 1 | 10 | M |
| Output fall time | R | Vcc=14V ; RL=820Ω ; CL=20pF | --- | 0.3 | 1.5 | US |

HTK38 Model Description Selection Code Table

HTK38 - 24 - A - 200 - 380 - O1 - O1 - 0 - 1 - T - A - N - 07
 ① ② ③ ④ ⑤ ⑥ ⑦ ⑧ ⑨ ⑩ ⑪ ⑫ ⑬

| | | | | | |
|---|---------------------------------------|---|--|---|-------------------------------------|
| ① | Product number | HTK38 | | | |
| ② | Voltage | 12=12V DC, 24=24V DC | | | |
| ③ | Load(n)@Speed (mm/s) | See page 06 | | | |
| ④ | Stroke(mm) | See page 06 | | | |
| ⑤ | Installation size(mm) | Note: Before selecting a size, please refer to the valid data sheet! See page 05 | | | |
| ⑥ | Upper type | O1 =Conventional ordinary type, hole diameter 8.5mm U1 = U-shaped, groove width 8mm, hole diameter 8.5mm M1 = Type M, M14 thread, depth 20 mm T1 = T-type, M14 thread, length 20mm L1 = L shape, width 8mm, aperture 8.5mm G1 = Spherical bearing, bore 10mm, model GS10 | O2 = Conventional ordinary type, hole diameter 10.5mm U2 = U-shaped, groove width 8mm, hole diameter 10.5mm M2 = MType M, M16 thread, depth20 mm T2 = T-type, M16 thread, length 20mm L2 = L shape, width 8mm, aperture 10.5mm G2 = Spherical bearing, bore 12mm, modelGS12 | | |
| ⑦ | lower type | O1 =Conventional ordinary type, hole diameter 8.5mm U1 = U-shaped, groove width 8mm, hole diameter 8.5mm | O2 = Conventional ordinary type, hole diameter 10.5mm U2 = U-shaped, groove width 8mm, hole diameter 10.5mm | | |
| ⑧ | Installation angle (counterclockwise) | 0 =0°, Degree | | 9 =90°, Degree | |
| ⑨ | Please refer to the outlet type | 1 = Dare wire 4 = Four-pin straight plug 7 = Waterproof plug | | 2 = 01 Straight plug 6 = Six-pin straight plug 0 = Customized | |
| ⑩ | Lead screw options | T = Trapezoidal screw (default preferred) | | G= Ball screw rod | |
| ⑪ | Control method | A = No Control | NY =Integrated wired control NW=Integrated wireless control | NT = Synchronous control NC = CAN bus | D= Customized |
| ⑫ | Signal output options | N = No | H =Hall sensor | D = Potentiometer | W=passive signal U=active signal |
| ⑬ | Cable length | 07 = 700mm 30 = 300mm | 10 = 1000mm 40 = 4000mm | 15 = 1500mm 70 = 7000mm | 20= 2000mm 00 =Customized |