

HTK

Series
Actuator

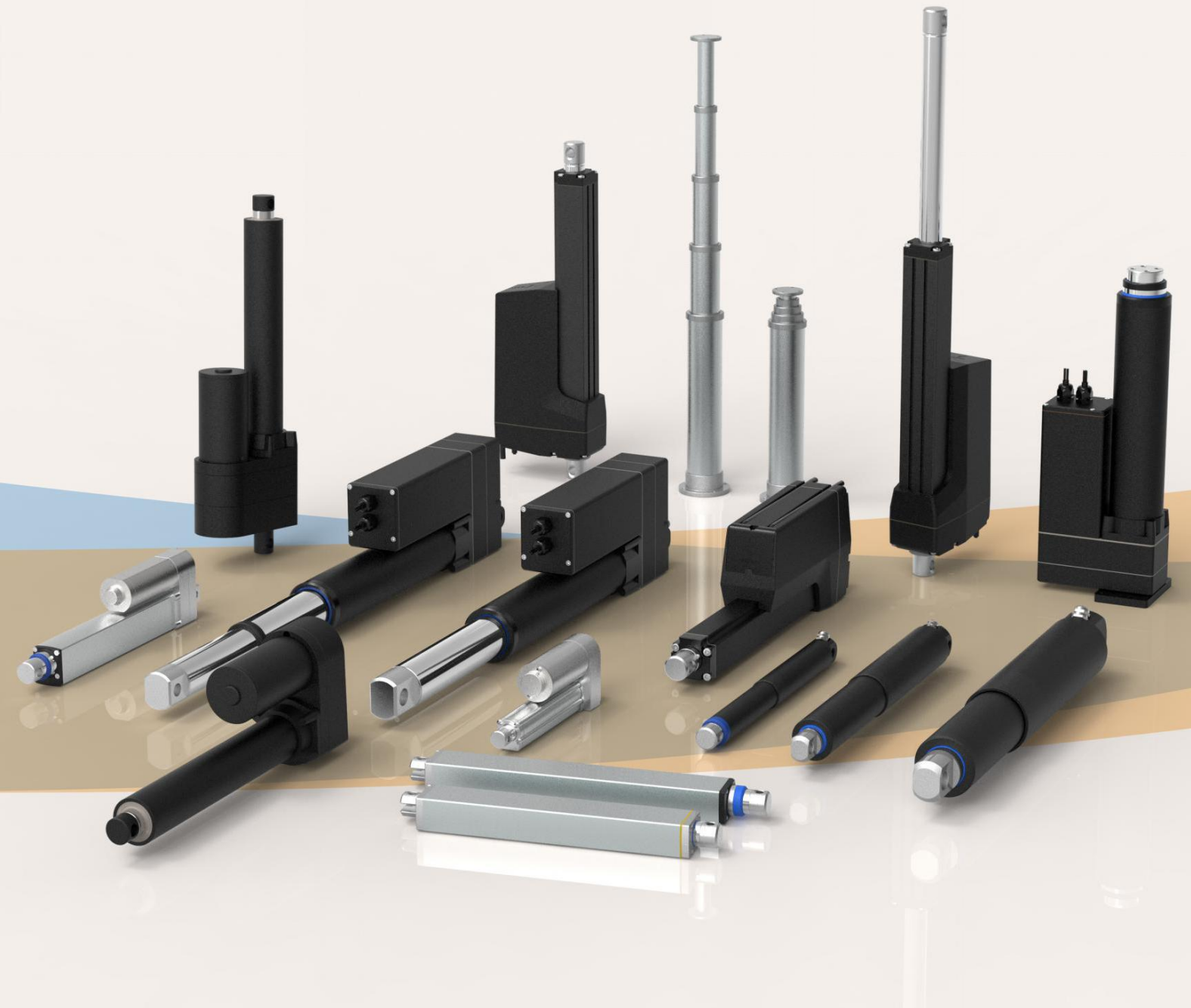

HTK55

Series

推杆执行器



Product Category

1. Industrial application
2. Automotive applications
3. Firefighting

Download 3D model



K55 and K75 have the same design, they are both linear linear actuators, mainly used in industrial applications requiring heavier loads. It is also ideal for product applications requiring smaller installation space. The waterproof level of this linear actuator can reach up to IP69 (optional). It can withstand high temperature, high-pressure water impact, and the entry of dust and other solid pollutants. It is suitable for construction machinery, ventilation systems, RV lifting fields, or food and Beverage automation equipment...etc.

Functional Overview

Voltage:	12V DC or 24V DC
Maximum thrust (pull force):	6,000N
Slowest speed under load:	3.0mm/s (load 6,000N)
Maximum speed under load:	94mm/s (load 200N)
Minimum installation size:	Stroke + 320mm
Dynamic lateral moment:	100Nm
Static lateral moment:	150Nm
color:	Silver gray, black
Voice:	52~58 DB
Adaptable temperature range:	-35°C ~ +75°C
Protection level:	IP66
Screw selection:	Trapezoidal screw, ball screw (default trapezoidal screw)
Switch type:	Built-in limit switch,
Signal options:	Hall sensor, active signal, passive signal,
Control options:	CE and RoHS regulations,
safety certificate:	Synchronous control, independent control Comply with ISO9001-2008,

For agricultural machinery applications

This is often critical for products operating under extreme conditions.

Electric actuators are suitable for harsh conditions filled with dust, dirt and water.

Even under these conditions, GeMinG electric actuators do not require regular maintenance.

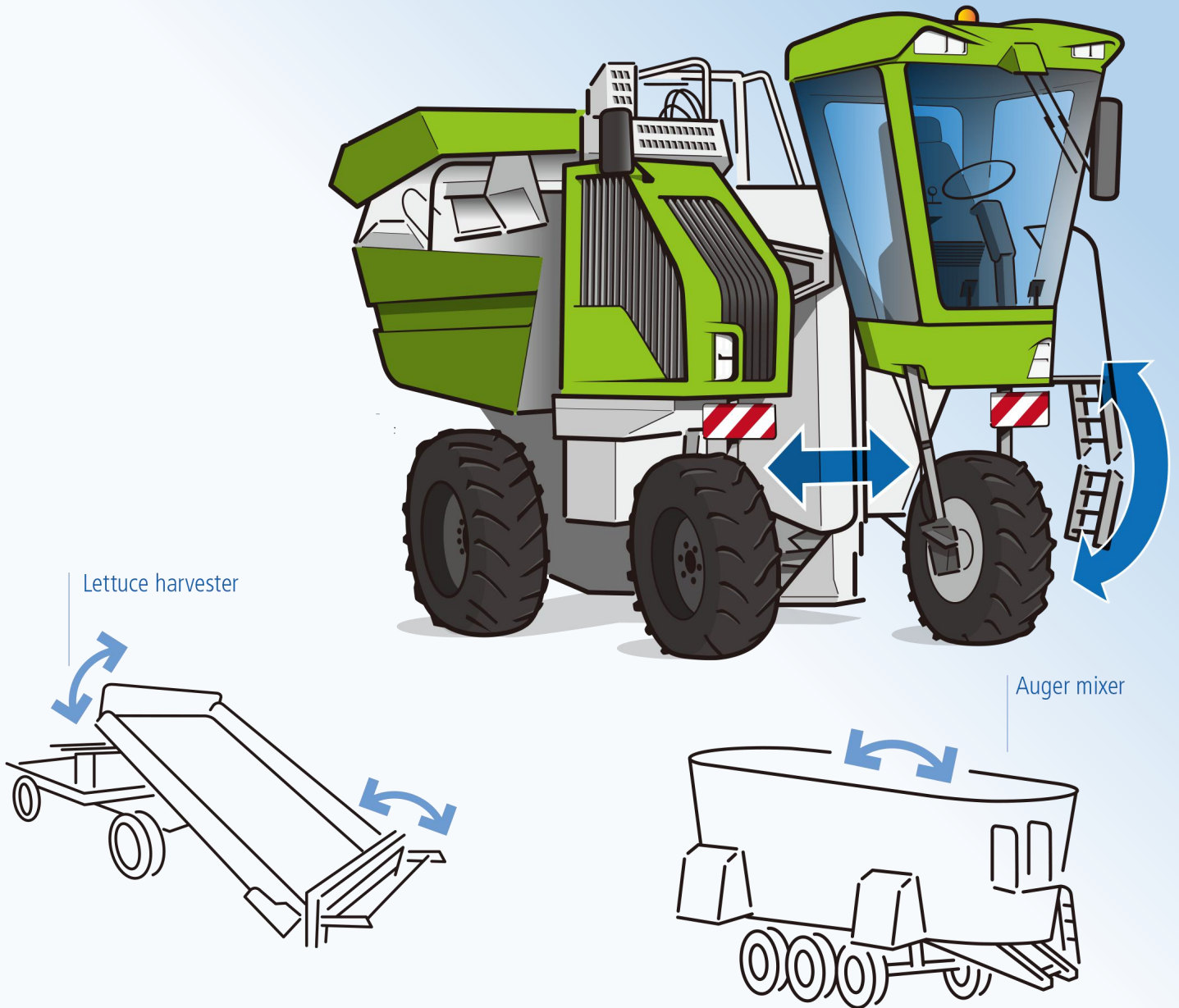

Drawings

Standard size
MM

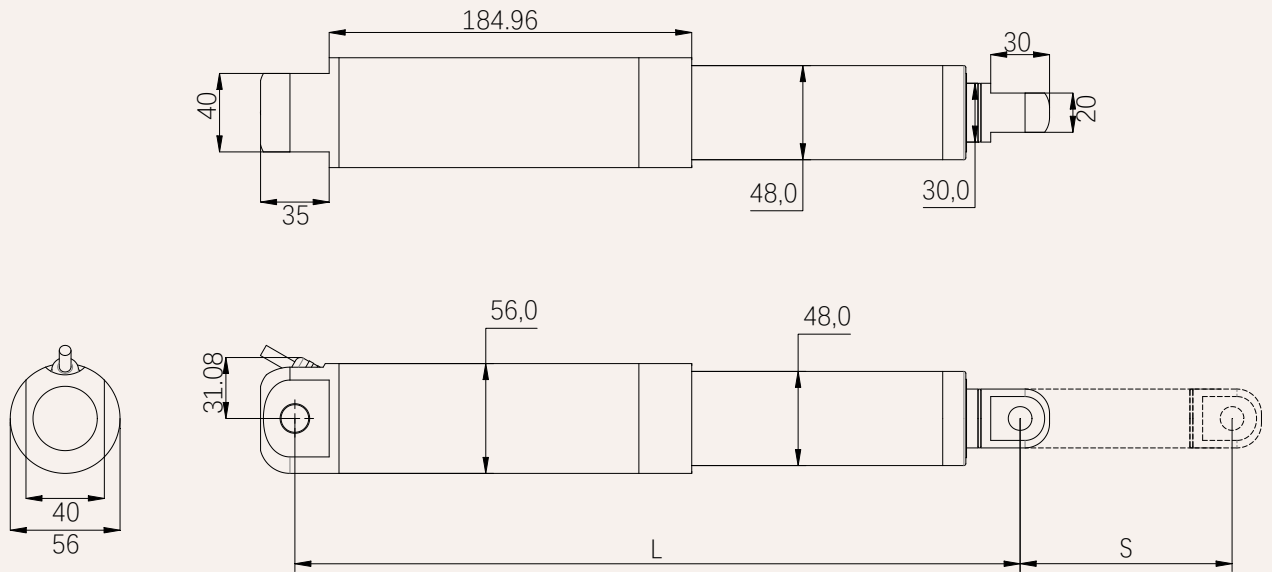

S: Stroke

L: Retracted length

L= Stroke +320mm

Greater than 600MM stroke L= Stroke +350MM

Installation angle (counterclockwise):

0 =0 Degrees

9 =90 Degrees

G=Adjust at will

load and speed

Code	Rated load Thrust N	Pull N	Self-locking force static conditions static N	Rated load current A	Output speed no load 24V DC mm/s	Rated load 24V DC mm/s
Motor voltage (24V DC)						
A	6,000	6,000	8,000	8.3	3.0	2.0
B	4,500	4,500	6,000	5.3	4.0	3.0
C	2,800	2,800	3,000	5.3	7.0	6.0
D	1,800	1,800	1,800	5.3	11.0	8.0
E	1,200	1,200	1,200	5.3	21	17
F	1000	1000	1000	5.3	31	25
G	650	650	650	5.3	62	50
H	300	300	300	5.3	95	75

Remark

1. The speed and current on the upper side are the materials that extend when pushed.
2. For 12V motor, the speed is about the same and the current is about 2 times higher.
3. The current & speed in the table are the test average values in the extension direction under thrust application.
4. The current & speed in the table and graph are the test average values of the GeMinG control box configuration, and there is an error of about 10% depending on the control box model.
(The voltage is about 29V DC at no load, and drops to about 24V DC at rated load)

Stroke: minimum value $\geq 20\text{mm}$, please refer to the table below for the maximum value of load and stroke

load (N)	Maximum stroke (mm)
2,000	50-200
1,200	201-300
1,000	301-400
800	401-600
600	601-900

Remark:

Lateral moment Y direction = $X \times 0.8$

Static lateral moment = dynamic $\times 2$

Dynamic lateral moment (Nm)-X direction

stroke	S+230	S+250
100-200	50	80
300-500	40	60
500-700	30	50
700-900	20	40

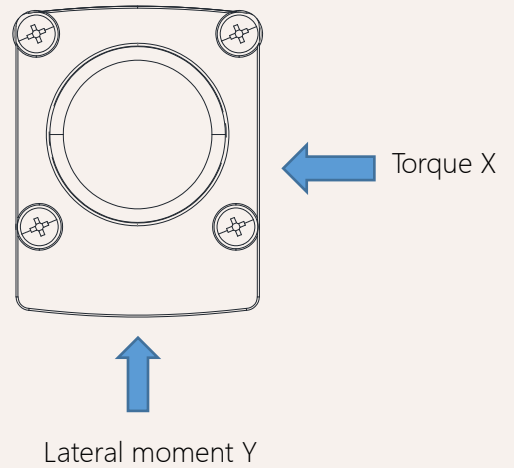

Stroke installation size reference chart

HTK55 Series	stroke ± 2 (mm)					Install ± 2 (mm)				
strokeMM	100	150	200	250	300	350	400	450	500	
Install MM	420	470	520	570	620	670	720	770	820	
weight KG	1,8	2.2	2.6	2.8	3.0	3.4	3.8	4.2	5.5	

Actuator wiring diagram

No signal feedback wiring diagram

Code: N

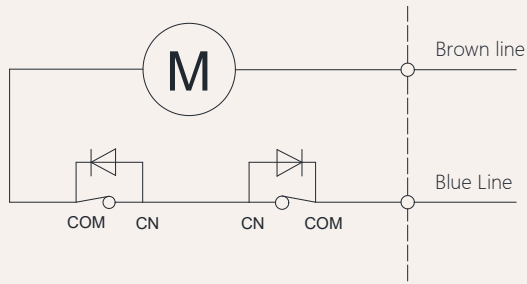

Wiring Instructions:

- 1] Brown lead: motor positive +
- 2] Blue lead: motor negative pole -
- 3] When the push rod is extended: the brown wire is positive +, the blue wire is negative -
- 4] When the push rod is retracted: the blue line is positive +, the brown line is negative -

Actuator wiring diagram Built-in control module

Built-in controller wiring diagram

Code: NY

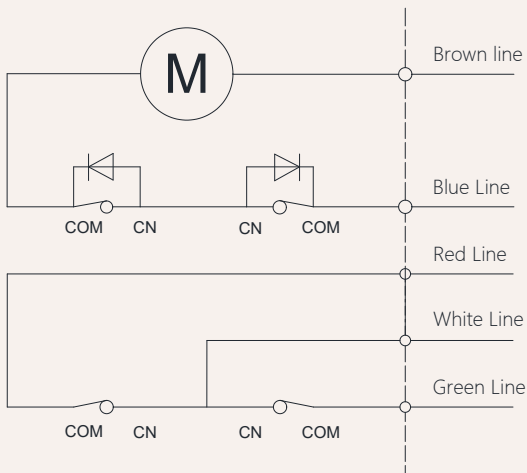

Wiring Instructions:

- 1] Brown lead: motor positive +
- 2] Blue lead: motor negative pole -
- 3] When the push rod is extended: white line + red line
- 4] When the push rod retracts: white line + green line
- 5] White line: control output common line.
- 6] White and red lines: stretch out,
- 7] White and green lines: retract,
- 8] Wireless remote control, use wired control simultaneously.

Other signal descriptions

Feedback signal	Description	Function
Active endpoint feedback signal	Voltage with this model	When the push rod reaches the end point, a signal will be fed back. This signal will always exist and will disappear during the operation of the push rod., When the push rod reaches the end point, it will feedback a signal. This signal always exists when the input power is not turned off. When the input power is turned off, the signal disappears. The signal will also disappear during the operation.
Passive endpoint feedback signal	No voltage	

Note: For other needs, please contact the GeMinG team

Signal feedback Hall sensor

Hall signal motor circuit diagram

Code: H

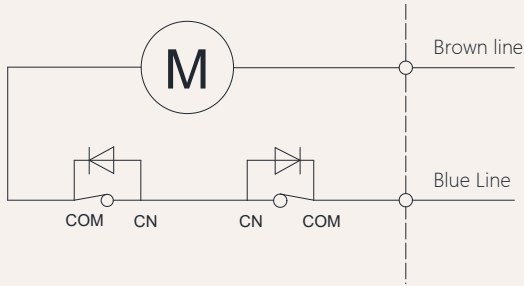

Hall signal output waveform diagram

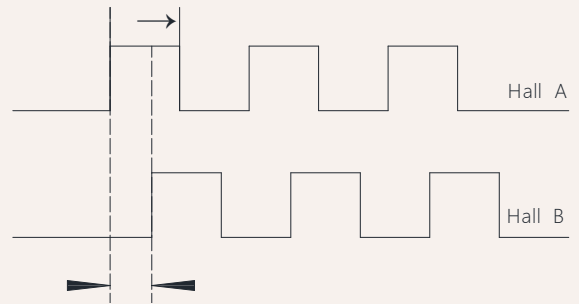

Schematic diagram of the internal circuit of the Hall signal

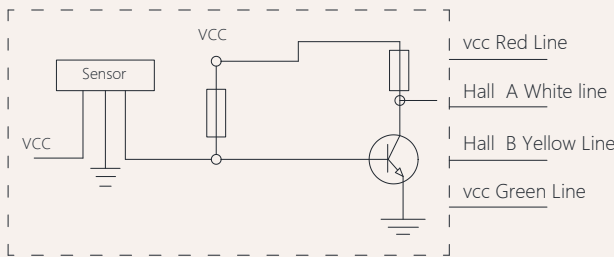

Wiring Instructions:

- 1] Brown lead: positive pole of motor +
- 2] Blue lead: negative pole of motor -
- 3] Red lead: VCC 5V voltage input +
- 4] Green lead: GND 5V voltage input -
- 5] White lead: Hall signal output A
- 6] Yellow lead: Hall signal output B

Notes:

- 1) Support dual-channel/single-channel Hall encoder
- 2) Current-consuming digital output
- 3) High-speed response frequency from: 0 KHz-100 KHz
- 4) Applicable temperature range:-40 °C~+125 °C

Characteristics	Symbol	Test conditions	MI	RE	M	Unit
Supply voltage	Vcc	----	3.5	---	24	V
Output saturation voltage	Vce/sat	Vcc=14V ; Ic=20mA	---	300	700	MV
Output leakage current	1 cex	Vce=14V ; Vcc=14V	---	<0	10	UA
Input voltage	1 ce	Vcc=20V ; Output open	---	1	10	M
Output fall time	R	Vcc=14V ; RL=820Ω ; CL=20pF	---	0.3	1.5	US

HTK55 Model Description Selection Code Table

HTK55 - 24 - A - 100 - 250 - O2 - O2 - 0 - 1 - T - A - N - 07
 ① ② ③ ④ ⑤ ⑥ ⑦ ⑧ ⑨ ⑩ ⑪ ⑫ ⑬

①	Product number	HTK55			
②	Voltage	12=12V DC, 24=24V DC			
③	Load(n)@Speed (mm/s)	See page 06			
④	Stroke(mm)	See page 06			
⑤	Installation size(mm)	Note: Before selecting a size, please refer to the valid data sheet! See page 05			
⑥	Upper type	O1 =Conventional ordinary type, hole diameter12.5mm U1 = U-shaped, groove width 8mm, hole diameter 12.5mm M1 = Type M, M16 thread, depth 20 mm T1 = T-type, M16 thread, length 20mm L1 = L shape, width 20mm, aperture 12.5mm G1 = Spherical bearing, bore 10mm, model GS14	O2 = Conventional ordinary type, hole diameter 13.5mm U2 = U-shaped, groove width 8mm, hole diameter 13.5mm M2 = MType M, M18 thread, depth20 mm T2 = T-type, M18 thread, length 20mm L2 = L shape, width 20mm, aperture 13.5mm G2 = Spherical bearing, bore 12mm, modelGS16		
⑦	lower type	O1 =Conventional ordinary type, hole diameter12.5mm U1 = U-shaped, groove width 8mm, hole diameter 2.5mm M1 = Type M, M16 thread, depth 20 mm T1 = T-type, M16 thread, length 20mm L1 = L type, width 20mm, hole diameter 12.5mm G1 = spherical plain bearing, bore diameter 14mm, type GS14	O2 = Conventional ordinary type, hole diameter 13.5mm U2 = U-shaped, groove width 8mm, hole diameter 13.5mm M2 = Type M, M18 thread, depth 20 m T2 = T-type, M18 thread, length 20mm L2 = L type, width 20mm, hole diameter 13.5mm G2 = spherical plain bearing, bore diameter 14mm, type GS16		
⑧	Installation angle (counterclockwise)	0 =0°, Degree		9 =90°, Degree	
⑨	Please refer to the outlet type	1 = Dare wire 4 = Four-pin straight plug 7 = Waterproof plug		2 = 01 Straight plug 6 = Six-pin straight plug 0 = Customized	
⑩	Lead screw options	T = Trapezoidal screw (default preferred)		G= Ball screw rod	
⑪	Control method	A = No Control	NY =Integrated wired control NW=Integrated wireless control	NT = Synchronous control NC = CAN bus	D= Customized
⑫	Signal output options	N = No	H =Hall sensor	D = Potentiometer	W=passive signal U=active signal
⑬	Cable length	07 = 700mm 30 = 300mm	10 = 1000mm 40 = 4000mm	15 = 1500mm 70 = 7000mm	20= 2000mm 00 =Customized

HTK55 Attachment Description Selection Code Table

Extended upper form :

O1 = Conventional ordinary type, hole diameter 12.5mm

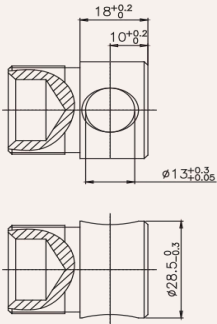

O2 = Conventional ordinary type, hole diameter 13.5mm

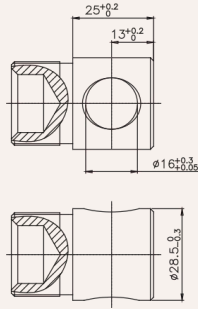

U1 = U-shaped, groove width 8mm, hole diameter 12.5mm

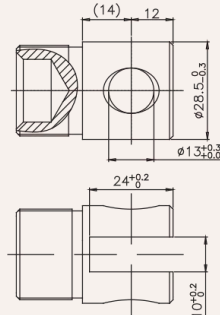

M2 = MType M, M18 thread, depth 20 mm

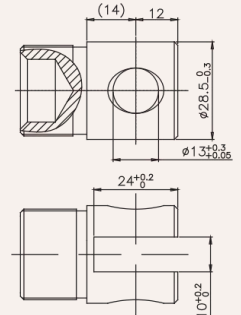

M1 = Type M, M16 thread, depth 20 mm

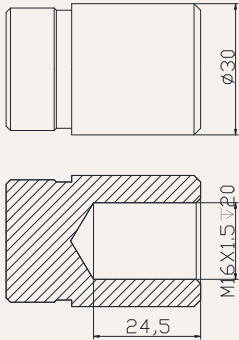

M2 = MType M, M18 thread, depth 20 mm

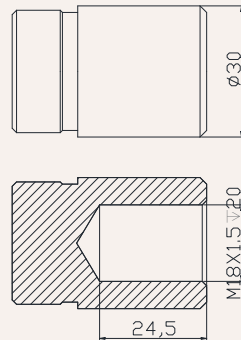

T1 = T-type, M16 thread, length 20mm

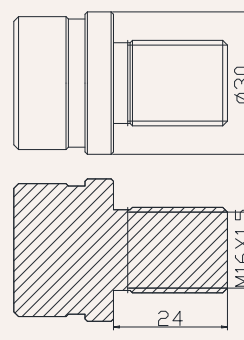

T2 = T-type, M18 thread, length 20mm

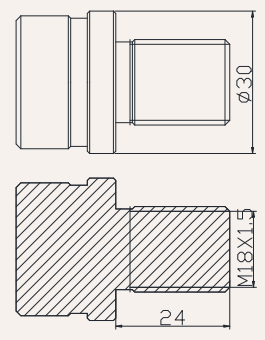

L1 = L shape, width 20mm, aperture 12.5mm

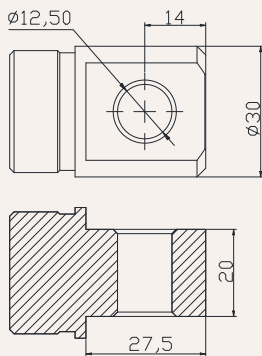

L2 = L shape, width 20mm, aperture 13.5mm

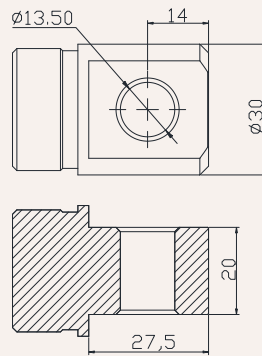

G1 = Spherical bearing, bore 10mm, model GS14

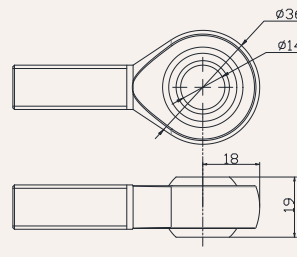

G2 = Spherical bearing, bore 10mm, model GS16

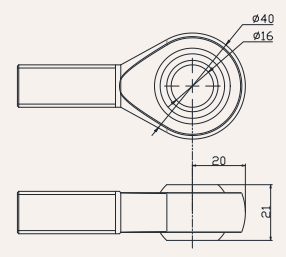

电源线形式:

1 = bare wire

2 = OI straight plug

4 = Four-pin straight plug

6 = Six-pin straight plug

